

APPENDIX C

Topographic Survey & Architect's Scheme Drawings

W:\Projects\5228 FRA, M and M, 2 sites on Bucklands Road, Teddington TW11 8SQ\2.3 Specifications & Reports\F. Flood Risk Assessments	Date March 2014	Job No. 5228/2.3F
---	--------------------	----------------------

Tree Schedule			
1	Sycamore	d=0.4	h=12
2	Silver birch	d=0.2	h=7
3	Sycamore	d=0.45	h=12
4	Sycamore	d=0.4	h=12
5	Sycamore	d=0.45	h=12
6	Ash	d=0.9	h=15
7	Silver birch	d=0.2	h=7
8	Willow	d=1	h=15
9	Willow	d=0.75	h=15
10	Willow	d=0.85	h=15
11	Unknown	d=0.95	h=10
12	Sycamore	d=0.95	h=16
13	Sycamore	d=0.3	h=10
14	Lime	d=0.5	h=12
15	Pine	d=0.45	h=12
16	Lime	d=0.6	h=14
17	Pine	d=0.25	h=7
18	Lime	d=0.6	h=14
19	Pine	d=0.4	h=15
20	Fruit	d=0.25	h=4
21	Lime	d=0.6	h=12
22	Holly	d=0.2	h=5
23	Laurel	d=0.2	h=5
24	Laurel	d=0.3	h=4



Hook Survey Legend

Hedge		Telephone line	
Undergrowth		Power line	
Tree		Banking	
Bush		Contour line	
Building		Survey Station	
Glass Building		Gate	
Open Building		Level	
Ordnance Survey Benchmark			
Foul Drainage			
Storm Drainage			

Abbreviations

Animal Set	Sett
Air Valve	AV
Borehole	BH
Bus Stop	BS
Cover Level	CL
Earth Rod	ER
Electricity Pole	EP
Fire Hydrant	FH
Inspection Cover	IC
Invert Level	IL
Lamp Post	LP
Manhole	MH
Marker	MK
Name Plate	RNP
Power Pole	PP
Rain water Pipe	RWP
Road Sign	RS
Roading Eye	RE
Reinforced Steel Joint	RSJ
Soil Vent Pipe	SVP
Stop Valve	SV
Survey Station	STN
Telegraph Pole	TP
Tree Stump	Stump
Trunk Hole	TH
Unable To Lift	UTL
Vent Pipe	VP
Water Valve	WV

Notes

All trees are identified where possible. Species, spread, height and girth are indicative only.

Drainage has been surveyed where found, and traced where possible.

Eaves and ridge heights of surrounding buildings have been surveyed where possible.

Survey control

Stn	Easting	Northing	Height
H1	517356.076	170956.646	6.353
H2	517345.317	170941.672	6.351
H3	517337.501	170926.779	6.361
H4	517330.183	170896.287	6.679
H5	517358.777	170886.509	6.641
H100	517290.047	170856.228	7.878
H101	517297.612	170887.905	7.240
H102	517300.491	170911.333	7.013
H103	517289.891	170919.535	6.857
H104	517304.539	170936.006	6.045

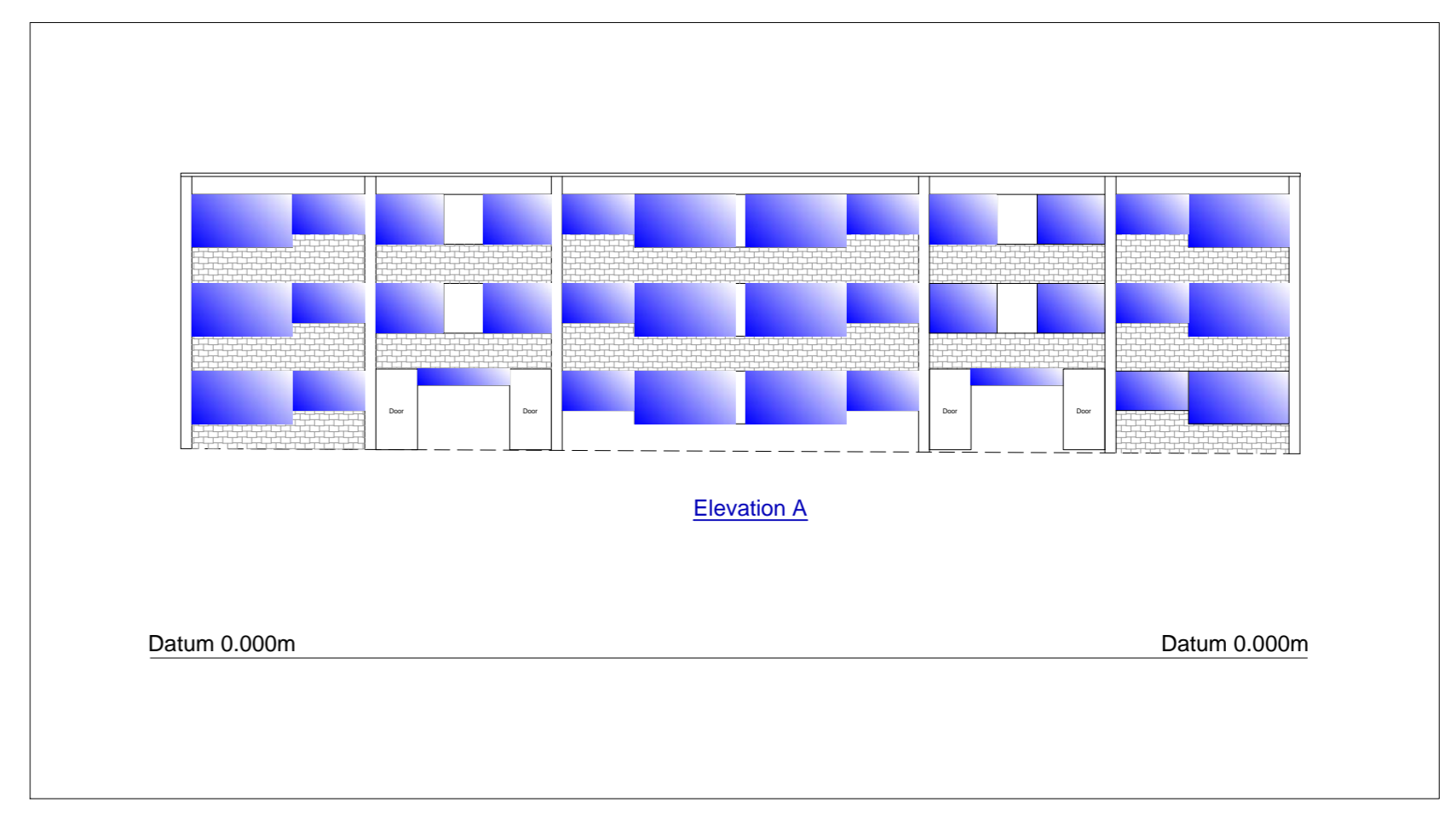

HOOK SURVEY PARTNERSHIP
Land & Building Surveyors
www.hooksurvey.com

Project: Garages at Bucklands Road, Richmond, London, TW11

Client: Richmond Housing Partnership

Drawing title: Topographical Survey

Job No.: S134059 | Dwg No.: S134059/01 | Revision: A

Scale: 1:200 | Date: January 2014 | Drawn by: N.B.

Grid & Levels related to: Pseudo Ordnance Survey Coordinate System at a scale of 1:0000 based around Stations H1 & H2

Head Office: Unit 1, Broom Farm, Orchard Way, Dartford, Kent, DA2 7ER. Email: mail@hooksurvey.com, Tel: 01322 277221

Midlands Office: 54 Stratford Road, Stratford on Avon, Warwickshire, CV36 4AG. Email: midlands@hooksurvey.com, Tel: 01608 430346

www.hooksurvey.com



Flood Risk Safe Route Strategy

The design level for a 1 in a 100 year flood event is 6.96m.

site A
The lowest finished floor level is set at 7.26m which allows for a climate change adjustment.

The safe route to dry land is form the front doors onto the raised walkway also at the 7.26m level which joins the footpath around the existing flat block and on to Broom Road which is outside of the flood zone 3.

Site B

The lowest finished floor level is set at 7.55m well above the required level of 7.26m.

The safe route to dry land is form the front doors, across the parking court to the higher level of Bucklands Road and on to Broom Road.

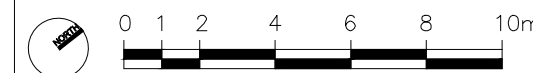

Notes

Notes/revisions:

Rev	Date	Drwn	Chkd
A	03.07.15	ma	
B	28.10.15	JL	

Design Developments following comments from consultation event
 Parking adjusted on site A & B for easy turning. Site B building plan adjusted to amended elevations following the meeting on 14.10.15

Date: JUN 2014	Client: Richmond Housing Partnership
Drawn: GC	Project: Bucklands Road
Check:	Title: Site Layout - Site A - Flood Risk Safe Route Strategy
Scale: 1: 500 @ A3	Dwgno: 12.143 / D(27)01
	Revision: B

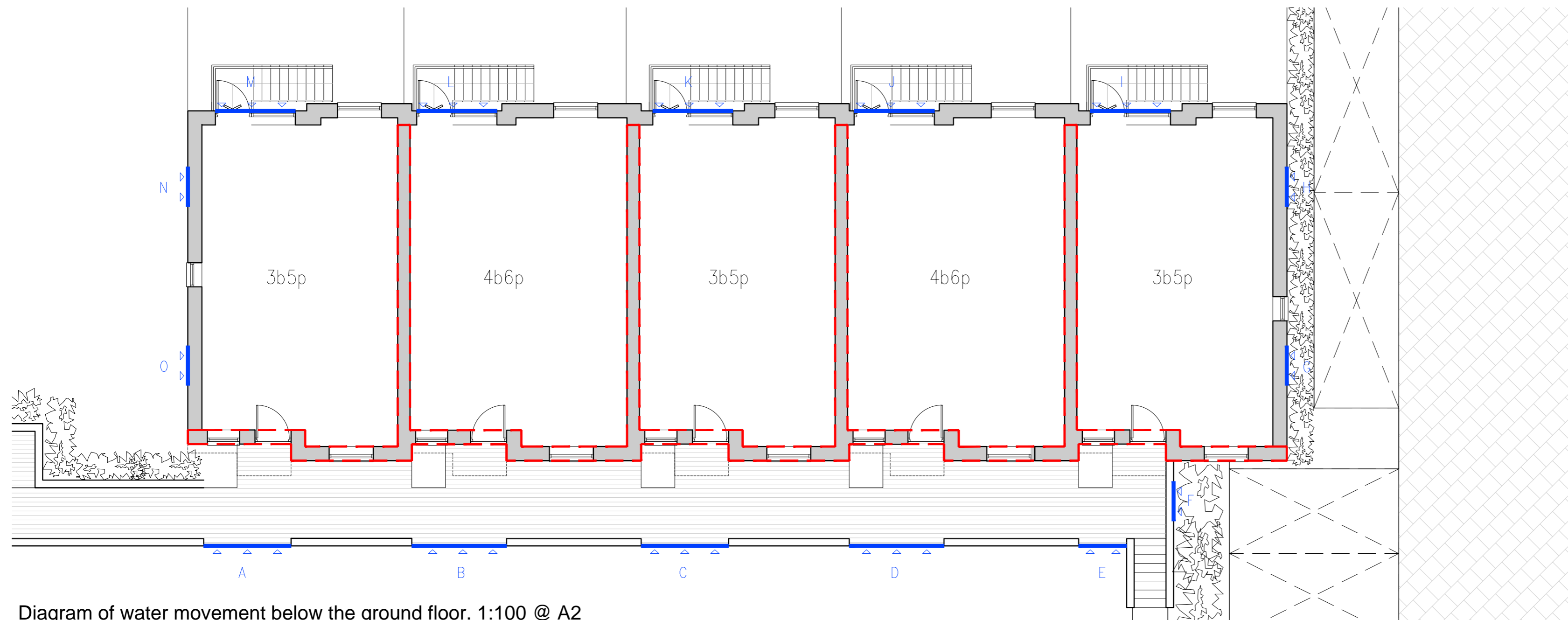

Water movement diagram key:

- Party walls below the ground floor to be hit/miss brickwork (or columns) with minimum 30% of openings to allow water movement in all directions.
- Metal grilles with 100mm metal louvers to allow water penetration under the ground floor with 15mm vermin mesh fixed to the back of louver panels.

Schedule of grilles		
	x	y
A	2475 mm	1207 mm
B	2685.7 mm	
C	2475 mm	
D	2685 mm	
E	1360 mm	
F	1125 mm	
G	1125 mm	
H	1125 mm	
I	2270 mm	
J	2270 mm	
K	2270 mm	
L	2270 mm	
M	2270 mm	
N	1125 mm	
O	1125 mm	

Diagram of water movement below the ground floor. 1:100 @ A2

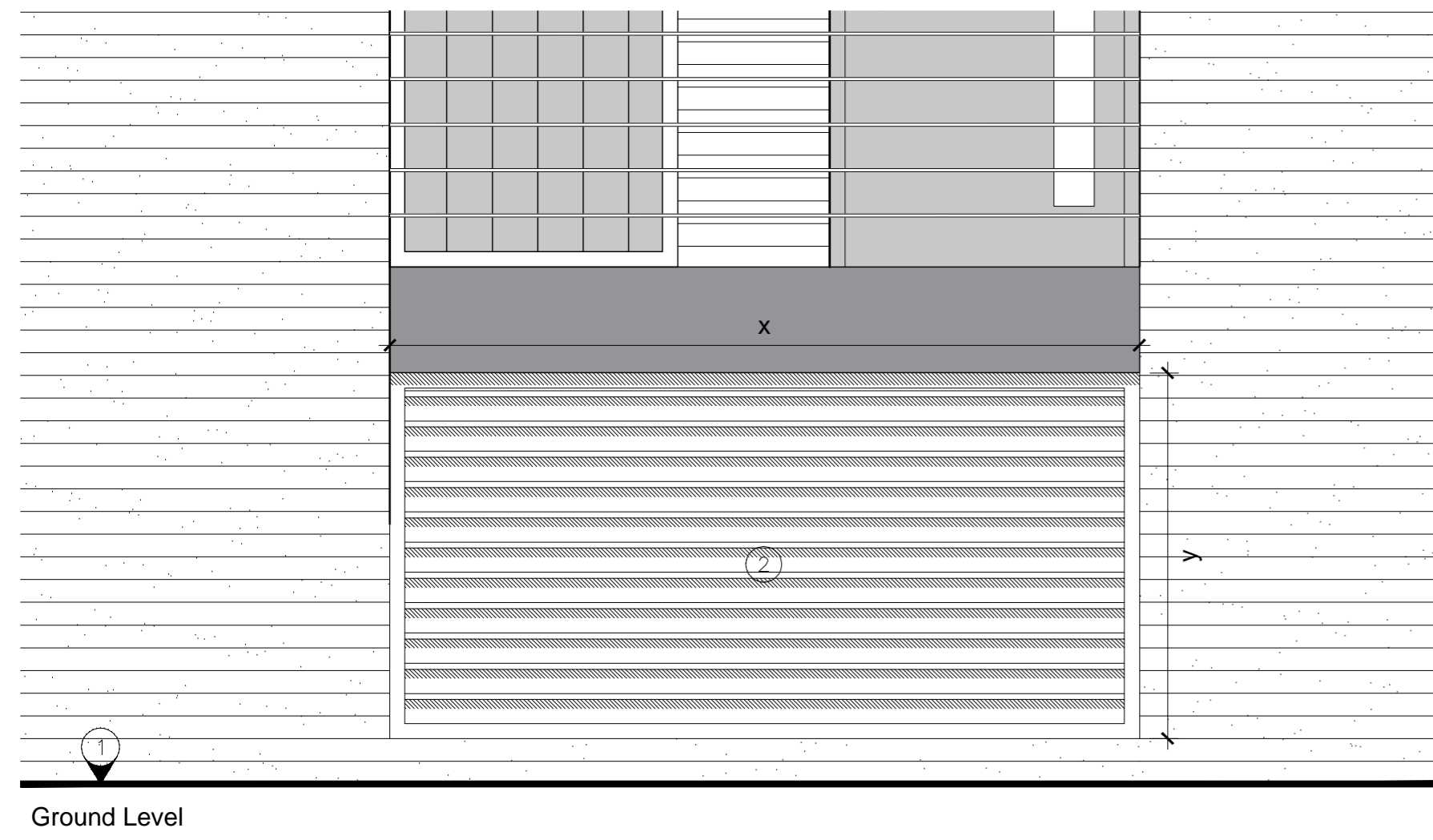

Building's Front elevation. 1:20 @ A2

Notes

--

Revisions:

Rev	Date	Drwn	Chkd

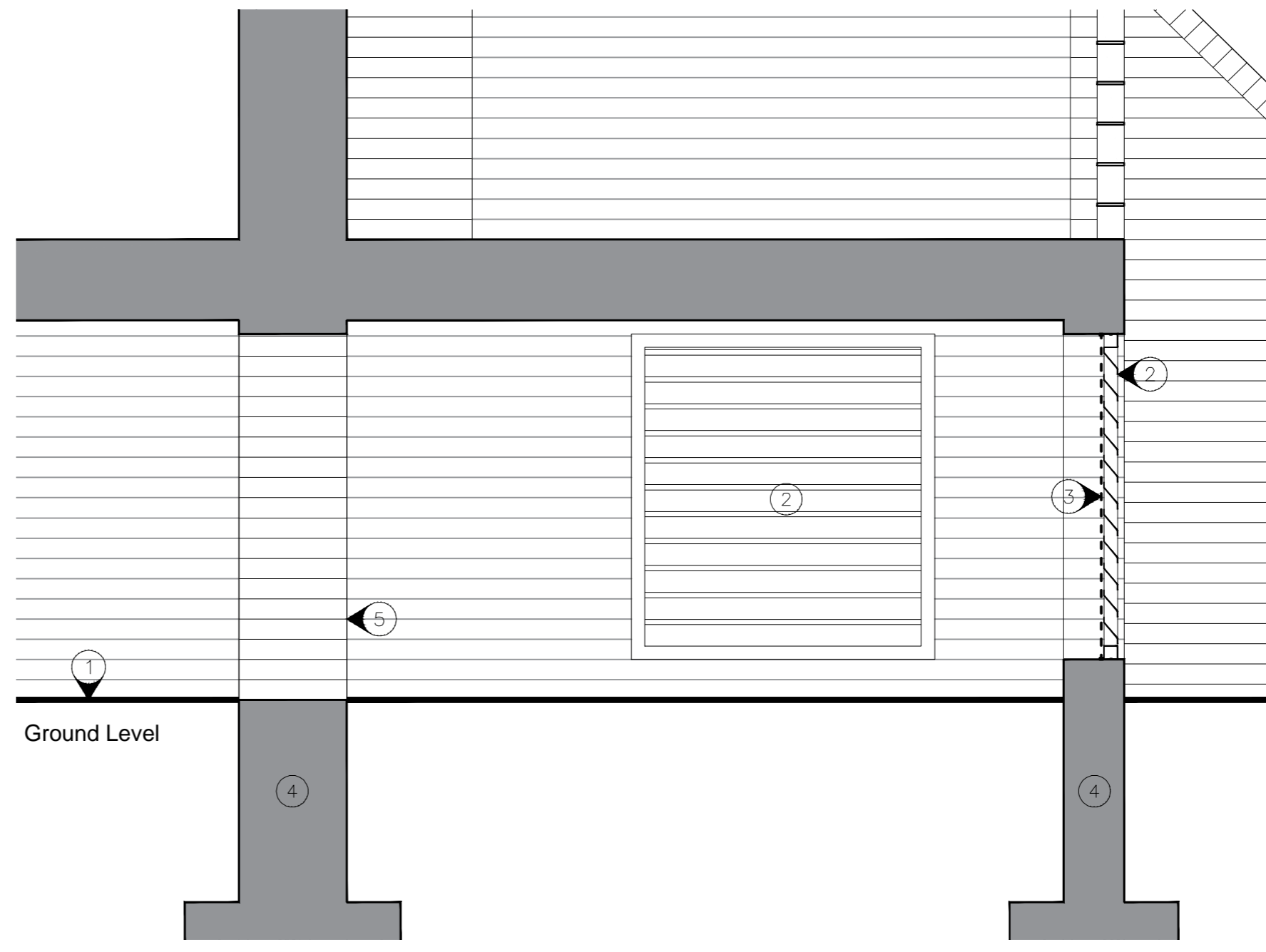

Under slab void. 1:20 @ A2

Under slab void detail key:

- ① Ground line.
- ② Metal grill with 100mm louvers to allow water penetration under the building.
- ③ 15mm vermin mesh fixed behind the grill.
- ④ Brick retaining wall.
- ⑤ min 30% of openings in the retaining wall below the ground floor level to minimise footprint and allow water movement under the building.

Revisions:

Rev	Date	Drwn	Chkd
P1	29/10/2015	JL	JL

Date: 23/10/2015	Client: Richmond Housing Partnership
Drawn: JL	Project: Bucklands Road
Check: JL	Title: Grilles and under slab void details (Site A)
Scale: As indicated	Dwgno: 12-143 / D(27)A-17
	Revision: P1

PRELIMINARY ISSUE

MATERIAL NOTES

- 1. London stock brick
- 2. Contrasting Lighter brick
- 3. Protruding brick rows detail
- 4. Metal window frames, colour: dark grey
- 5. Glass and metal canopy
- 6. Metal Grill
- 7. Metal Railing

REAR ELEV (A) (1:100)



NORTH-EAST ELEV (A) (1:100)



SOUTH-WEST ELEV (A) (1:100)

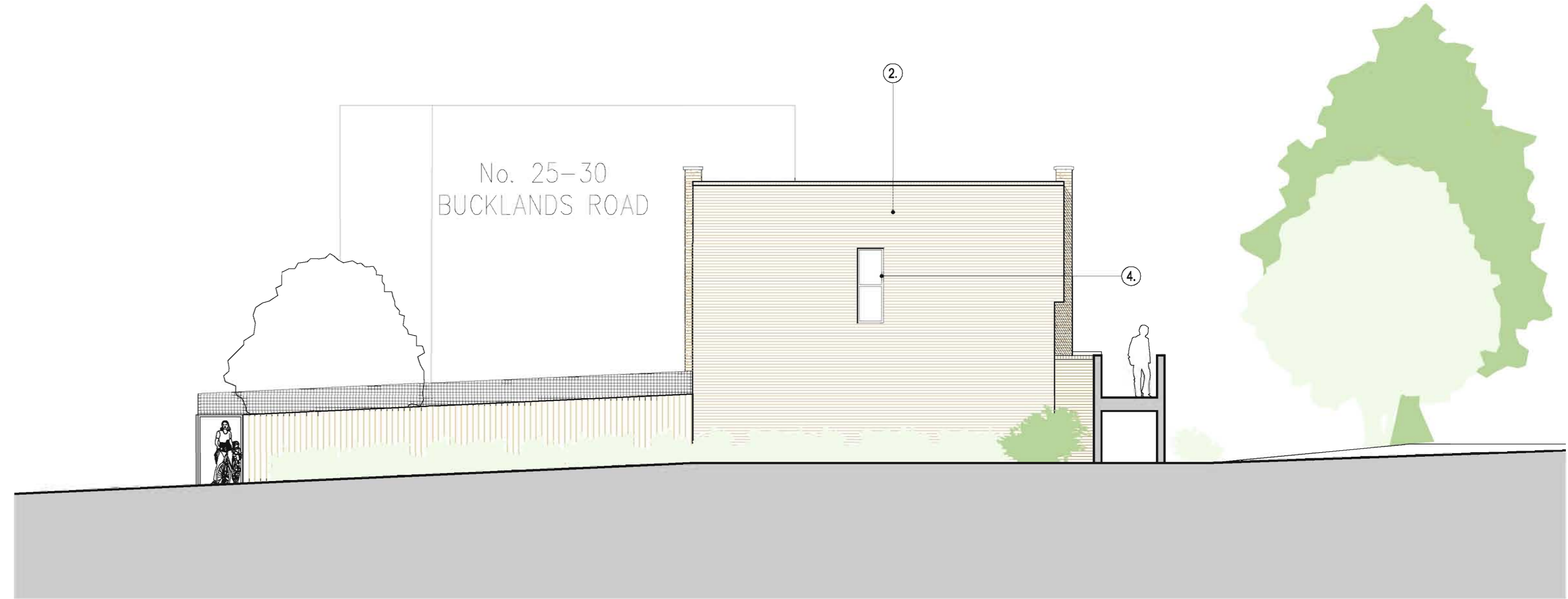

Notes:

Planning Application only - Not for construction purposes. This drawing is copyright of bptw partnership.

Revisions:

Rev	Date	Drawn	Check

Revisions:

Rev	Date	Drawn	Check

Revisions:

Rev	Date	Drawn	Check

Date: JUN 2014	Client: Richmond Housing Partnership
Drawn: GC	Project: Bucklands Road
Check:	Title: Rear & Side Elevations - Site A
Scale: 1: 100 @ A1	Dwgno: 12.143/ D(27)A-15
Revision:	

MATERIAL NOTES

- 1. London stock brick
- 2. Contrasting Lighter brick
- 3. Protruding brick rows detail
- 4. Metal window frames, colour: dark grey
- 5. Glass and metal canopy
- 6. Metal Grill
- 7. Metal Railing

STREET SCENE (A) (1:100)



SITE SECTION (A) (1:100)

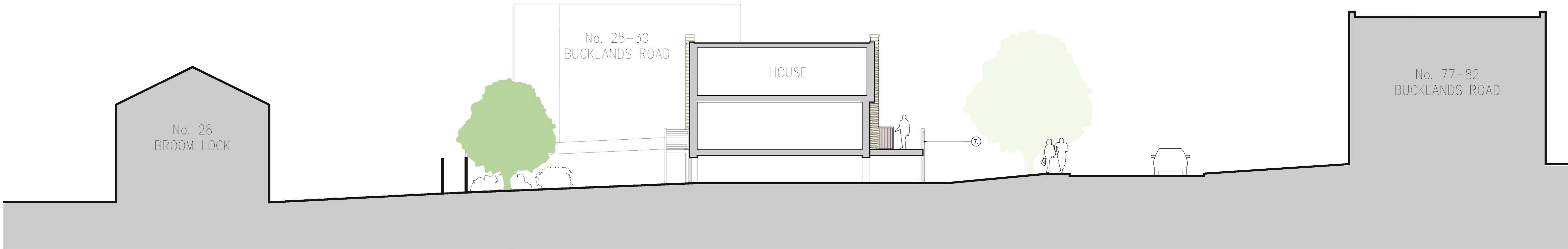

Notes:
 Planning Application only - Not for construction purposes. This drawing is copyright of bptw partnership.

Revisions:

Rev	Date	Drawn	Check

Revisions:

Rev	Date	Drawn	Check

Revisions:

Rev	Date	Drawn	Check

Date: JUN 2014	Client: Richmond Housing Partnership
Drawn: GC	Project: Bucklands Road
Check:	Title: Front elevation and section - Site A
Scale: 1: 100@A1	Dwgno: 12.143 / D(27)A-14
	Revision:

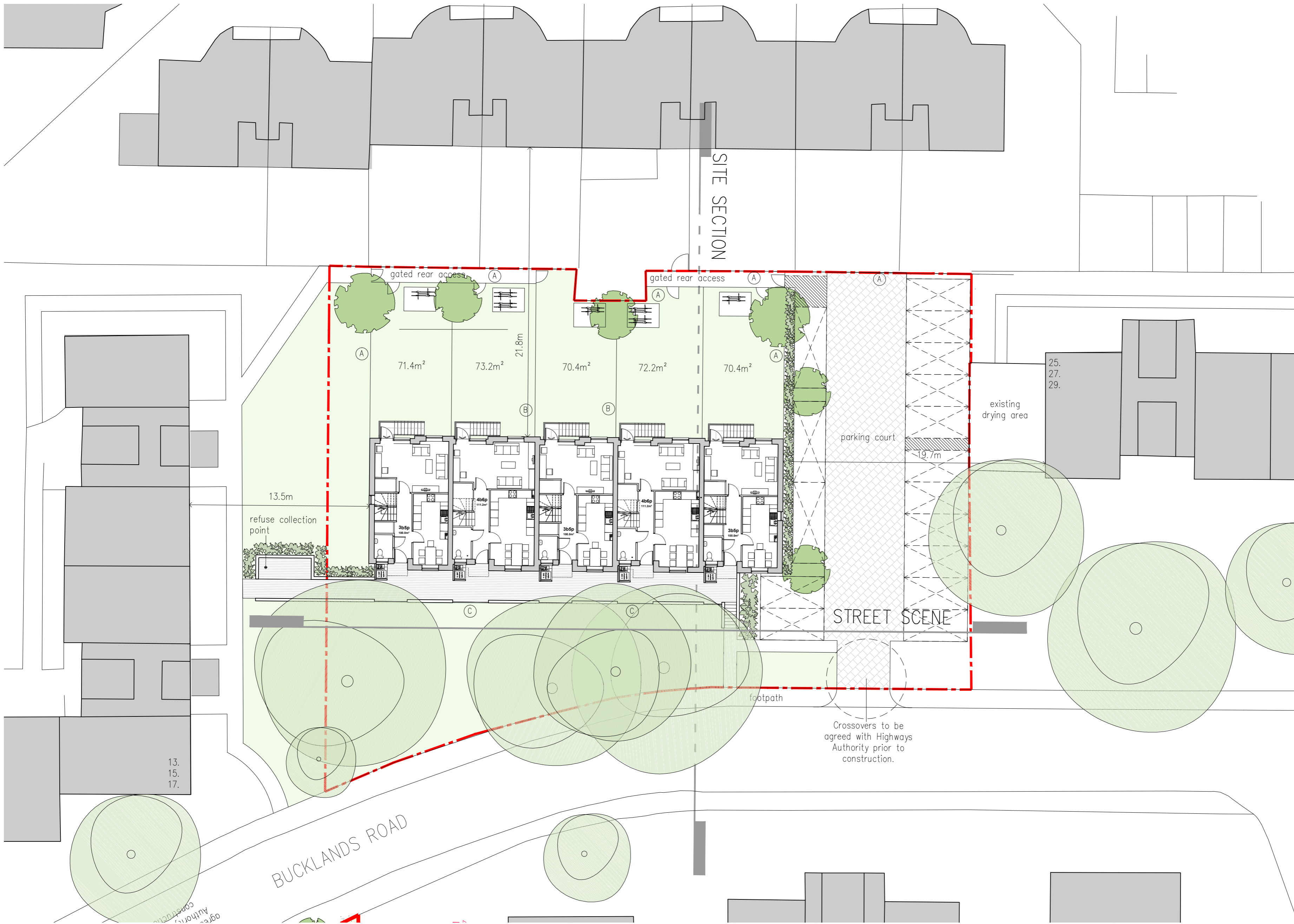

Type	Acc.	Area (m sq)	No of units	Parking one/one
House	4B/6P	111.2	2	2
House	3B/5P	100	3	3
Add.				11
Totals			5	16

Site Area (Ha) 0.16

KEY

- existing tree
- proposed new tree
- tree to be removed
- 1.8m high close boarded timber fence with 450mm trellis
- 1.8m high privacy screen for 2m followed by 1200mm close boarded fence topped with 600mm trellis
- 1100mm high metal railings

Notes

--

Revisions:

Rev	Date	Drwn	Chkd

Revisions:

Rev	Date	Drwn	Chkd
A	03.07.15	ma	JL
B	28.10.15	JL	

Date: JUN 2014	Client: Richmond Housing Partnership
Drawn: GC	Project: Bucklands Road
Check:	Title: Site Layout - Site A
Scale: 1: 200@A2	Dwgno: 12.143 / D(27)A-11
	Revision: B



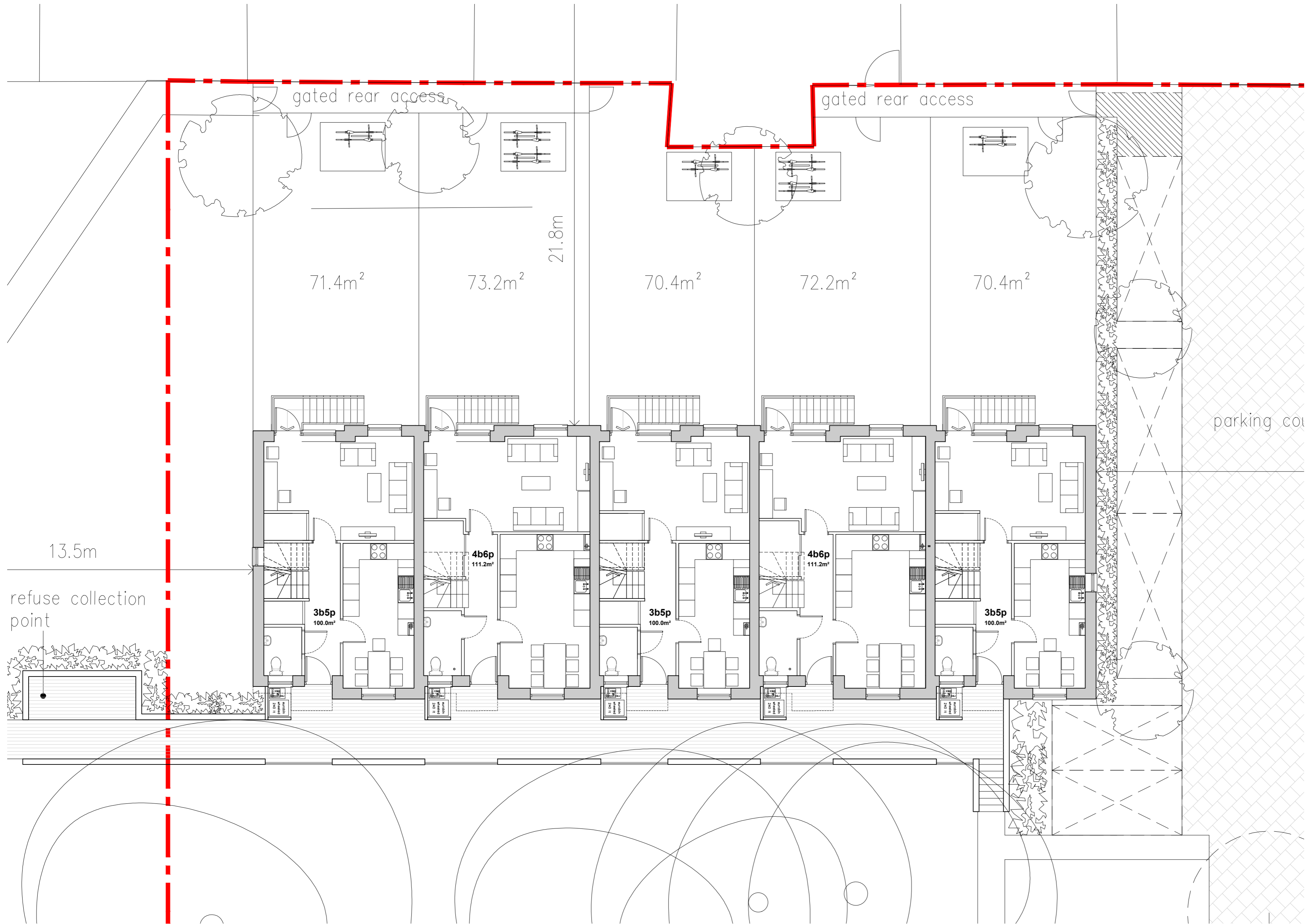

Type	Acc.	Area (m sq)	No of units	Parking one/one
House	4B/6P	111.2	2	2
House	3B/5P	100	3	3
Add.				11
Totals			5	16

Site Area (Ha) 0.16

Site A - Ground Floor Plan



Notes

Revisions:

Rev	Date	Drwn	Chkd
A	27.10.15	JL	

Revisions:

Rev	Date	Drwn	Chkd





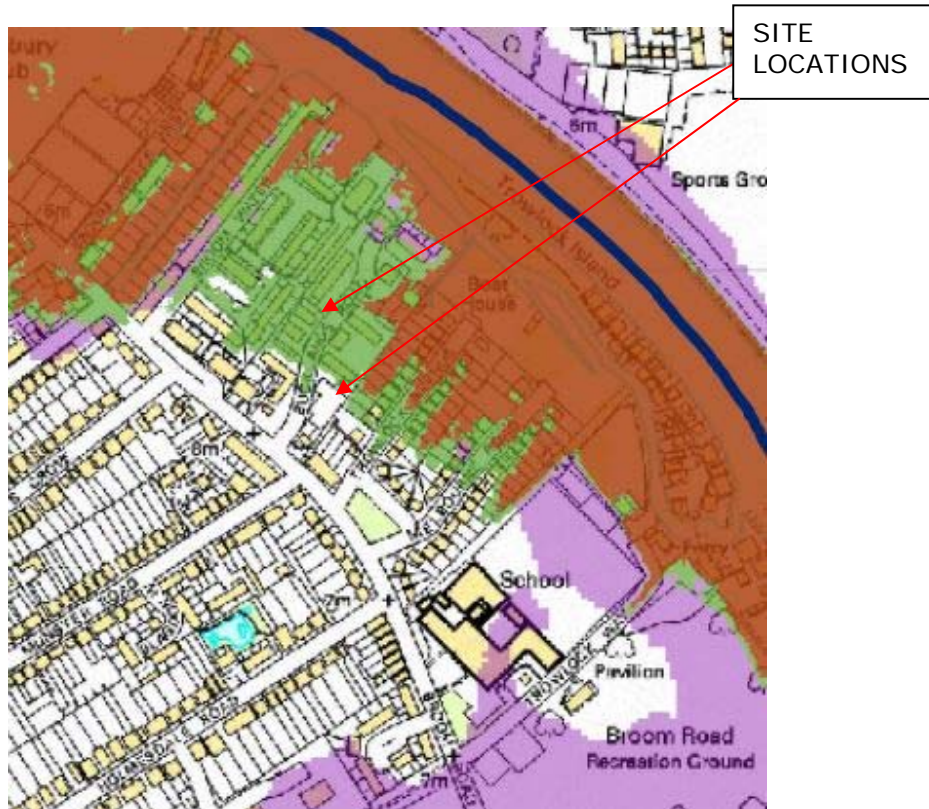

Date: JUN 2014	Client: Richmond Housing Partnership
Drawn: GC	Project: Bucklands Road
Check:	Title: Ground Floor Plan - Site A
Scale: 1:100@A2	Dwgno: 12.143 / D(27)A-12
	Revision: A

APPENDIX D

SFRA Maps



Legend

-  Flood defences
-  Borough Boundary
-  Localised Drainage Issues
-  Zone 3b Functional Floodplain
-  Zone 3a High Probability
-  Zone 2 Medium Probability

Flood zone map – Site A is within FZ3A, and Site B is which FZ1. These differ to the EA flood map zones.

W:\Projects\5228 FRA, M and M, 2 sites on Bucklands Road, Teddington TW11 8SQ\2.3 Specifications & Reports\F. Flood Risk Assessments	Date March 2014	Job No. 5228/2.3F
---	--------------------	----------------------

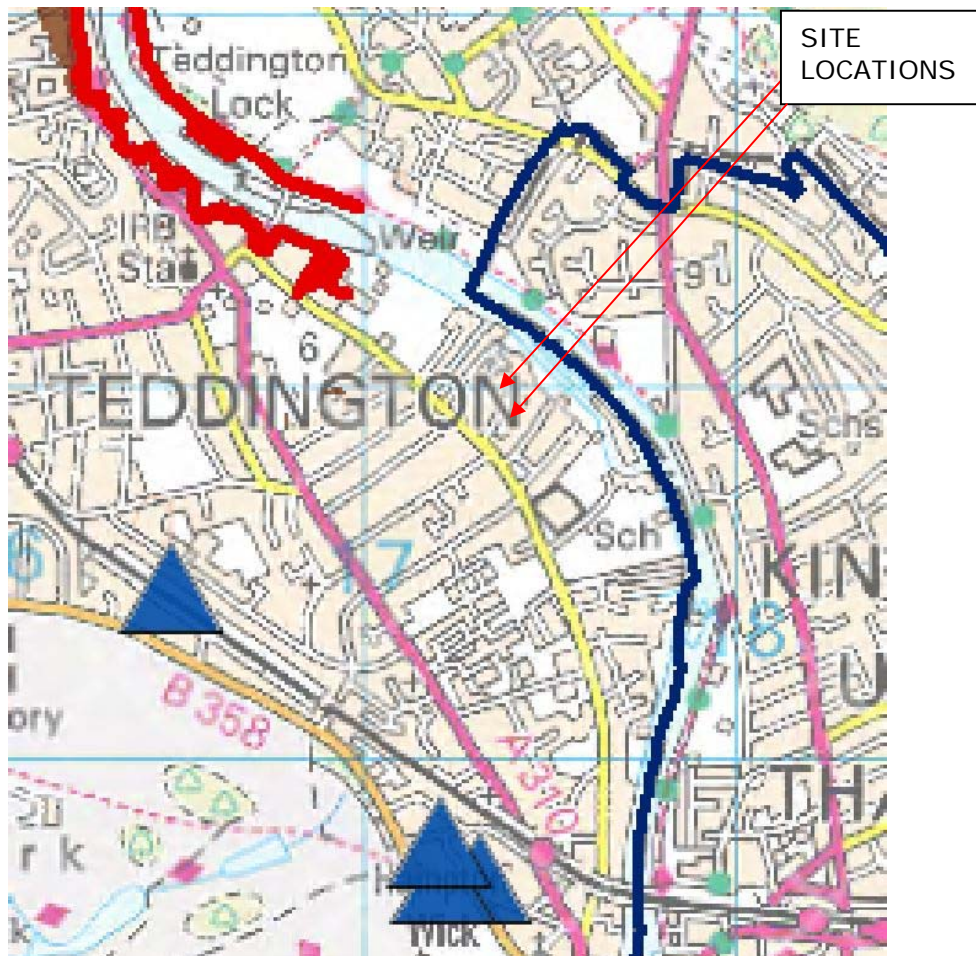

Legend

- Areas benefitting from flood defences
- Groundwater Flooding Incidents
- Flood defences
- BoroBoundary

Groundwater Flooding Map – the sites have had no groundwater flooding incidents.

W:\Projects\5228 FRA, M and M, 2 sites on Bucklands Road, Teddington TW11 8SQ\2.3 Specifications & Reports\F. Flood Risk Assessments	Date March 2014	Job No. 5228/2.3F
---	--------------------	----------------------

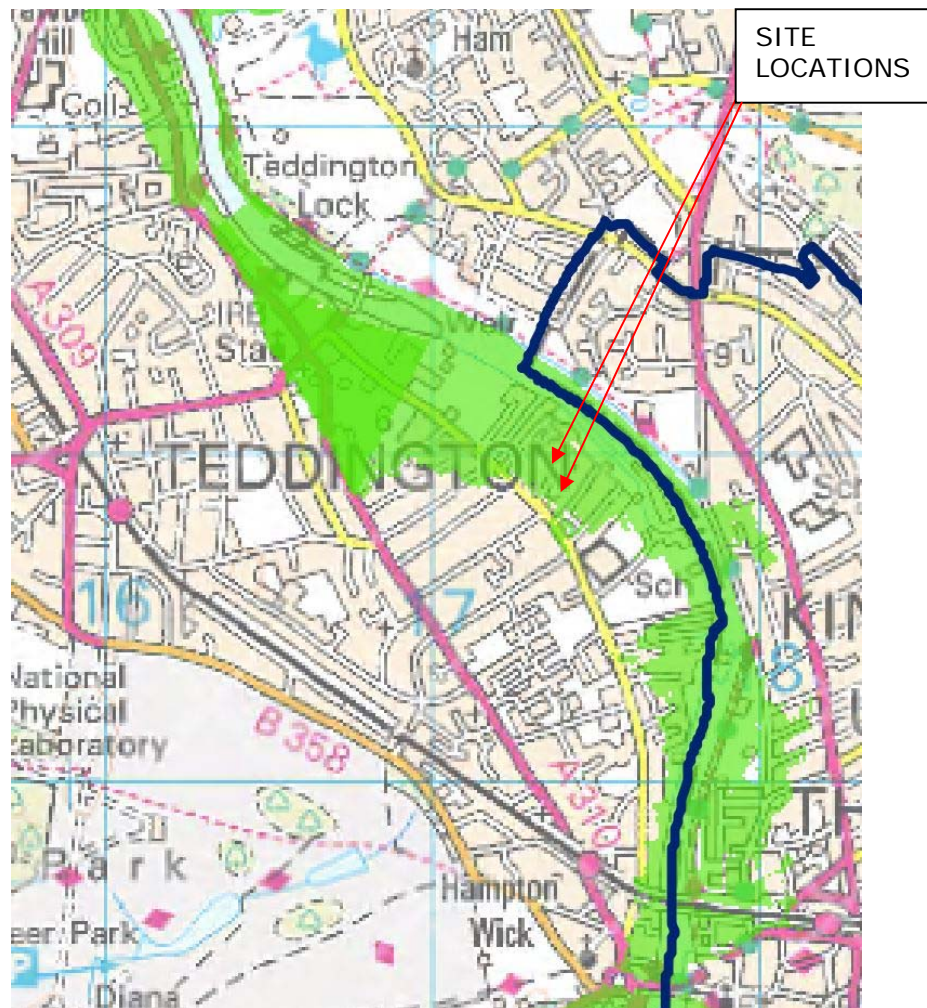

Legend

- Impacts of Climate Change on Zone 3a
- Borough Boundary

Effect of Climate Change on Flood Zones Map – Both sites will be in FZ3 in 100 years due to climate change.

W:\Projects\5228 FRA, M and M, 2 sites on Bucklands Road, Teddington TW11 8SQ\2.3 Specifications & Reports\F. Flood Risk Assessments	Date March 2014	Job No. 5228/2.3F
---	--------------------	----------------------

APPENDIX E

Micro Drainage Calculation

W:\Projects\5228 FRA, M and M, 2 sites on Bucklands Road, Teddington TW11 8SQ\2.3 Specifications & Reports\F. Flood Risk Assessments	Date March 2014	Job No. 5228/2.3F
---	--------------------	----------------------

GTA Civils Ltd		Page 1
Gloucester House 66a Church Walk Burgess Hill RH15 9AS	Site A Bucklands Road Attenuation Tank and Hydrobrake 'lin100+30%'	
Date 06.03.14 File site A.srcx	Designed by CJ Checked by JP	
Micro Drainage		Source Control 2013.1

Summary of Results for 100 year Return Period (+30%)

Half Drain Time : 6 minutes.

Storm Event	Max Level (m)	Max Depth (m)	Max Infiltration (l/s)	Max Control (l/s)	Max Σ Outflow (l/s)	Max Volume (m³)	Status
15 min Summer	8.686	0.686	0.0	19.2	19.2	9.8	O K
30 min Summer	8.671	0.671	0.0	19.2	19.2	9.6	O K
60 min Summer	8.486	0.486	0.0	19.2	19.2	6.9	O K
120 min Summer	8.264	0.264	0.0	17.6	17.6	3.8	O K
180 min Summer	8.193	0.193	0.0	14.3	14.3	2.8	O K
240 min Summer	8.159	0.159	0.0	11.8	11.8	2.3	O K
360 min Summer	8.124	0.124	0.0	8.7	8.7	1.8	O K
480 min Summer	8.105	0.105	0.0	7.0	7.0	1.5	O K
600 min Summer	8.092	0.092	0.0	5.9	5.9	1.3	O K
720 min Summer	8.083	0.083	0.0	5.1	5.1	1.2	O K
960 min Summer	8.071	0.071	0.0	4.0	4.0	1.0	O K
1440 min Summer	8.057	0.057	0.0	2.9	2.9	0.8	O K
2160 min Summer	8.046	0.046	0.0	2.1	2.1	0.7	O K
2880 min Summer	8.040	0.040	0.0	1.7	1.7	0.6	O K
4320 min Summer	8.032	0.032	0.0	1.2	1.2	0.5	O K
5760 min Summer	8.028	0.028	0.0	1.0	1.0	0.4	O K
7200 min Summer	8.025	0.025	0.0	0.8	0.8	0.4	O K
8640 min Summer	8.022	0.022	0.0	0.7	0.7	0.3	O K
10080 min Summer	8.021	0.021	0.0	0.6	0.6	0.3	O K
15 min Winter	8.777	0.777	0.0	19.7	19.7	11.1	O K
30 min Winter	8.708	0.708	0.0	19.3	19.3	10.1	O K
60 min Winter	8.409	0.409	0.0	19.2	19.2	5.8	O K

Storm Event	Rain (mm/hr)	Flooded Volume (m³)	Discharge Volume (m³)	Time-Peak (mins)
15 min Summer	130.490	0.0	20.1	13
30 min Summer	84.962	0.0	26.1	21
60 min Summer	52.662	0.0	32.4	36
120 min Summer	31.544	0.0	38.8	66
180 min Summer	23.073	0.0	42.6	94
240 min Summer	18.380	0.0	45.2	124
360 min Summer	13.286	0.0	49.0	184
480 min Summer	10.557	0.0	51.9	244
600 min Summer	8.826	0.0	54.3	306
720 min Summer	7.621	0.0	56.2	364
960 min Summer	6.042	0.0	59.4	488
1440 min Summer	4.349	0.0	64.2	734
2160 min Summer	3.126	0.0	69.2	1100
2880 min Summer	2.471	0.0	72.9	1436
4320 min Summer	1.771	0.0	78.4	2176
5760 min Summer	1.398	0.0	82.5	2840
7200 min Summer	1.162	0.0	85.8	3552
8640 min Summer	1.000	0.0	88.5	4336
10080 min Summer	0.880	0.0	90.9	5056
15 min Winter	130.490	0.0	22.5	13
30 min Winter	84.962	0.0	29.3	22
60 min Winter	52.662	0.0	36.3	38

Gloucester House
66a Church Walk
Burgess Hill RH15 9AS

Site A Bucklands Road
Attenuation Tank and
Hydrobrake 'lin100+30%'



Date 06.03.14
File site A.srcx

Designed by CJ
Checked by JP

Micro Drainage Source Control 2013.1

Summary of Results for 100 year Return Period (+30%)

Storm Event	Max Level (m)	Max Depth (m)	Max Infiltration (1/s)	Max Control (1/s)	Max Σ Outflow (1/s)	Max Volume (m³)	Status
120 min Winter	8.199	0.199	0.0	14.7	14.7	2.8	O K
180 min Winter	8.150	0.150	0.0	11.0	11.0	2.1	O K
240 min Winter	8.125	0.125	0.0	8.8	8.8	1.8	O K
360 min Winter	8.098	0.098	0.0	6.4	6.4	1.4	O K
480 min Winter	8.083	0.083	0.0	5.1	5.1	1.2	O K
600 min Winter	8.074	0.074	0.0	4.3	4.3	1.0	O K
720 min Winter	8.067	0.067	0.0	3.7	3.7	0.9	O K
960 min Winter	8.057	0.057	0.0	2.9	2.9	0.8	O K
1440 min Winter	8.046	0.046	0.0	2.1	2.1	0.7	O K
2160 min Winter	8.037	0.037	0.0	1.5	1.5	0.5	O K
2880 min Winter	8.032	0.032	0.0	1.2	1.2	0.5	O K
4320 min Winter	8.026	0.026	0.0	0.9	0.9	0.4	O K
5760 min Winter	8.023	0.023	0.0	0.7	0.7	0.3	O K
7200 min Winter	8.020	0.020	0.0	0.6	0.6	0.3	O K
8640 min Winter	8.018	0.018	0.0	0.5	0.5	0.3	O K
10080 min Winter	8.017	0.017	0.0	0.4	0.4	0.2	O K

Storm Event	Rain (mm/hr)	Flooded Volume (m³)	Discharge Volume (m³)	Time-Peak (mins)
120 min Winter	31.544	0.0	43.4	66
180 min Winter	23.073	0.0	47.7	94
240 min Winter	18.380	0.0	50.6	124
360 min Winter	13.286	0.0	54.9	186
480 min Winter	10.557	0.0	58.2	244
600 min Winter	8.826	0.0	60.8	306
720 min Winter	7.621	0.0	63.0	362
960 min Winter	6.042	0.0	66.6	490
1440 min Winter	4.349	0.0	71.9	726
2160 min Winter	3.126	0.0	77.5	1100
2880 min Winter	2.471	0.0	81.7	1424
4320 min Winter	1.771	0.0	87.8	2156
5760 min Winter	1.398	0.0	92.4	2856
7200 min Winter	1.162	0.0	96.1	3672
8640 min Winter	1.000	0.0	99.1	4328
10080 min Winter	0.880	0.0	101.8	5048

Gloucester House
66a Church Walk
Burgess Hill RH15 9AS

Site A Bucklands Road
Attenuation Tank and
Hydrobrake 'lin100+30%'



Date 06.03.14
File site A.srcx

Designed by CJ
Checked by JP

Micro Drainage

Source Control 2013.1

Rainfall Details

Rainfall Model	FSR	Winter Storms	Yes
Return Period (years)	100	Cv (Summer)	0.750
Region	England and Wales	Cv (Winter)	0.840
M5-60 (mm)	20.000	Shortest Storm (mins)	15
Ratio R	0.420	Longest Storm (mins)	10080
Summer Storms	Yes	Climate Change %	+30

Time Area Diagram

Total Area (ha) 0.082

Time (mins) Area
From: To: (ha)

0 4 0.082

GTA Civils Ltd		Page 4
Gloucester House 66a Church Walk Burgess Hill RH15 9AS	Site A Bucklands Road Attenuation Tank and Hydrobrake 'lin100+30%'	
Date 06.03.14 File site A.srcx	Designed by CJ Checked by JP	
Micro Drainage	Source Control 2013.1	

Model Details

Storage is Online Cover Level (m) 10.000

Cellular Storage Structure

Invert Level (m) 8.000 Safety Factor 2.0
 Infiltration Coefficient Base (m/hr) 0.00000 Porosity 0.95
 Infiltration Coefficient Side (m/hr) 0.00000

Depth (m)	Area (m ²)	Inf. Area (m ²)	Depth (m)	Area (m ²)	Inf. Area (m ²)
0.000	15.0	15.0	0.900	0.0	27.8
0.800	15.0	27.8			

Hydro-Brake® Outflow Control

Design Head (m) 0.800 Hydro-Brake® Type Md5 SW Only Invert Level (m) 8.000
 Design Flow (l/s) 20.0 Diameter (mm) 188

Depth (m)	Flow (l/s)	Depth (m)	Flow (l/s)	Depth (m)	Flow (l/s)	Depth (m)	Flow (l/s)
0.100	6.6	1.200	23.4	3.000	36.8	7.000	56.3
0.200	14.8	1.400	25.2	3.500	39.8	7.500	58.3
0.300	18.4	1.600	26.9	4.000	42.5	8.000	60.2
0.400	19.2	1.800	28.5	4.500	45.1	8.500	62.0
0.500	19.0	2.000	30.1	5.000	47.6	9.000	63.8
0.600	19.0	2.200	31.6	5.500	49.9	9.500	65.6
0.800	19.9	2.400	33.0	6.000	52.1		
1.000	21.6	2.600	34.3	6.500	54.2		

GTA Civils Ltd		Page 1
Gloucester House 66a Church Walk Burgess Hill RH15 9AS	Site B Bucklands Road Attenuation Tank and Hydrobrake 'lin100+30%'	
Date 06.03.14 File site B.srcx	Designed by CJ Checked by JP	
Micro Drainage		Source Control 2013.1

Summary of Results for 100 year Return Period (+30%)

Half Drain Time : 8 minutes.

Storm Event	Max Level (m)	Max Depth (m)	Max Infiltration (l/s)	Max Control (l/s)	Max Σ Outflow (l/s)	Max Volume (m³)	Status
15 min Summer	8.696	0.696	0.0	14.8	14.8	11.2	O K
30 min Summer	8.711	0.711	0.0	14.6	14.6	11.5	O K
60 min Summer	8.591	0.591	0.0	14.7	14.7	9.5	O K
120 min Summer	8.307	0.307	0.0	14.8	14.8	5.0	O K
180 min Summer	8.203	0.203	0.0	13.4	13.4	3.3	O K
240 min Summer	8.164	0.164	0.0	11.3	11.3	2.6	O K
360 min Summer	8.126	0.126	0.0	8.5	8.5	2.0	O K
480 min Summer	8.106	0.106	0.0	6.8	6.8	1.7	O K
600 min Summer	8.093	0.093	0.0	5.7	5.7	1.5	O K
720 min Summer	8.084	0.084	0.0	5.0	5.0	1.4	O K
960 min Summer	8.072	0.072	0.0	3.9	3.9	1.2	O K
1440 min Summer	8.058	0.058	0.0	2.8	2.8	0.9	O K
2160 min Summer	8.047	0.047	0.0	2.1	2.1	0.8	O K
2880 min Summer	8.040	0.040	0.0	1.6	1.6	0.7	O K
4320 min Summer	8.033	0.033	0.0	1.2	1.2	0.5	O K
5760 min Summer	8.028	0.028	0.0	0.9	0.9	0.5	O K
7200 min Summer	8.025	0.025	0.0	0.8	0.8	0.4	O K
8640 min Summer	8.023	0.023	0.0	0.7	0.7	0.4	O K
10080 min Summer	8.022	0.022	0.0	0.6	0.6	0.3	O K
15 min Winter	8.792	0.792	0.0	14.9	14.9	12.8	O K
30 min Winter	8.782	0.782	0.0	14.8	14.8	12.6	O K
60 min Winter	8.577	0.577	0.0	14.7	14.7	9.3	O K

Storm Event	Rain (mm/hr)	Flooded Volume (m³)	Discharge Volume (m³)	Time-Peak (mins)
15 min Summer	130.490	0.0	19.6	13
30 min Summer	84.962	0.0	25.5	22
60 min Summer	52.662	0.0	31.6	38
120 min Summer	31.544	0.0	37.9	68
180 min Summer	23.073	0.0	41.5	96
240 min Summer	18.380	0.0	44.1	124
360 min Summer	13.286	0.0	47.8	184
480 min Summer	10.557	0.0	50.7	244
600 min Summer	8.826	0.0	52.9	306
720 min Summer	7.621	0.0	54.9	366
960 min Summer	6.042	0.0	58.0	488
1440 min Summer	4.349	0.0	62.6	728
2160 min Summer	3.126	0.0	67.5	1096
2880 min Summer	2.471	0.0	71.1	1432
4320 min Summer	1.771	0.0	76.5	2136
5760 min Summer	1.398	0.0	80.5	2936
7200 min Summer	1.162	0.0	83.7	3568
8640 min Summer	1.000	0.0	86.4	4408
10080 min Summer	0.880	0.0	88.7	5096
15 min Winter	130.490	0.0	21.9	14
30 min Winter	84.962	0.0	28.5	23
60 min Winter	52.662	0.0	35.4	42

Gloucester House
66a Church Walk
Burgess Hill RH15 9AS

Site B Bucklands Road
Attenuation Tank and
Hydrobrake 'lin100+30%'



Date 06.03.14
File site B.srcx

Designed by CJ
Checked by JP

Micro Drainage Source Control 2013.1

Summary of Results for 100 year Return Period (+30%)

Storm Event	Max Level (m)	Max Depth (m)	Max Infiltration (l/s)	Max Control (l/s)	Max Σ Outflow (l/s)	Max Volume (m³)	Status
120 min Winter	8.217	0.217	0.0	13.9	13.9	3.5	O K
180 min Winter	8.155	0.155	0.0	10.7	10.7	2.5	O K
240 min Winter	8.127	0.127	0.0	8.6	8.6	2.1	O K
360 min Winter	8.099	0.099	0.0	6.2	6.2	1.6	O K
480 min Winter	8.084	0.084	0.0	5.0	5.0	1.4	O K
600 min Winter	8.075	0.075	0.0	4.2	4.2	1.2	O K
720 min Winter	8.068	0.068	0.0	3.6	3.6	1.1	O K
960 min Winter	8.058	0.058	0.0	2.8	2.8	0.9	O K
1440 min Winter	8.047	0.047	0.0	2.1	2.1	0.8	O K
2160 min Winter	8.038	0.038	0.0	1.5	1.5	0.6	O K
2880 min Winter	8.033	0.033	0.0	1.2	1.2	0.5	O K
4320 min Winter	8.027	0.027	0.0	0.8	0.8	0.4	O K
5760 min Winter	8.023	0.023	0.0	0.7	0.7	0.4	O K
7200 min Winter	8.021	0.021	0.0	0.6	0.6	0.3	O K
8640 min Winter	8.019	0.019	0.0	0.5	0.5	0.3	O K
10080 min Winter	8.018	0.018	0.0	0.4	0.4	0.3	O K

Storm Event	Rain (mm/hr)	Flooded Volume (m³)	Discharge Volume (m³)	Time-Peak (mins)
120 min Winter	31.544	0.0	42.4	66
180 min Winter	23.073	0.0	46.5	96
240 min Winter	18.380	0.0	49.4	126
360 min Winter	13.286	0.0	53.6	186
480 min Winter	10.557	0.0	56.7	246
600 min Winter	8.826	0.0	59.3	306
720 min Winter	7.621	0.0	61.4	364
960 min Winter	6.042	0.0	65.0	490
1440 min Winter	4.349	0.0	70.1	734
2160 min Winter	3.126	0.0	75.6	1080
2880 min Winter	2.471	0.0	79.7	1468
4320 min Winter	1.771	0.0	85.7	2200
5760 min Winter	1.398	0.0	90.2	2840
7200 min Winter	1.162	0.0	93.7	3640
8640 min Winter	1.000	0.0	96.7	4488
10080 min Winter	0.880	0.0	99.3	4992

Gloucester House
66a Church Walk
Burgess Hill RH15 9AS

Site B Bucklands Road
Attenuation Tank and
Hydrobrake 'lin100+30%'



Date 06.03.14
File site B.srcx

Designed by CJ
Checked by JP

Micro Drainage

Source Control 2013.1

Rainfall Details

Rainfall Model	FSR	Winter Storms	Yes
Return Period (years)	100	Cv (Summer)	0.750
Region	England and Wales	Cv (Winter)	0.840
M5-60 (mm)	20.000	Shortest Storm (mins)	15
Ratio R	0.420	Longest Storm (mins)	10080
Summer Storms	Yes	Climate Change %	+30

Time Area Diagram

Total Area (ha) 0.080

Time (mins)		Area
From:	To:	(ha)

0	4	0.080
---	---	-------

Gloucester House
66a Church Walk
Burgess Hill RH15 9AS

Site B Bucklands Road
Attenuation Tank and
Hydrobrake 'lin100+30%'



Date 06.03.14
File site B.srcx

Designed by CJ
Checked by JP

Micro Drainage

Source Control 2013.1

Model Details

Storage is Online Cover Level (m) 10.000

Cellular Storage Structure

Invert Level (m) 8.000 Safety Factor 2.0
Infiltration Coefficient Base (m/hr) 0.00000 Porosity 0.95
Infiltration Coefficient Side (m/hr) 0.00000

Depth (m)	Area (m ²)	Inf. Area (m ²)	Depth (m)	Area (m ²)	Inf. Area (m ²)
0.000	17.0	17.0	0.900	0.0	33.8
0.800	17.0	33.8			

Hydro-Brake® Outflow Control

Design Head (m) 0.800 Diameter (mm) 159
Design Flow (l/s) 15.0 Invert Level (m) 8.000
Hydro-Brake® Type Mdl2 SW Only

Depth (m)	Flow (l/s)	Depth (m)	Flow (l/s)	Depth (m)	Flow (l/s)	Depth (m)	Flow (l/s)
0.100	6.3	1.200	18.3	3.000	28.9	7.000	44.2
0.200	13.3	1.400	19.8	3.500	31.3	7.500	45.8
0.300	14.7	1.600	21.1	4.000	33.4	8.000	47.3
0.400	13.5	1.800	22.4	4.500	35.4	8.500	48.7
0.500	13.0	2.000	23.6	5.000	37.4	9.000	50.1
0.600	13.4	2.200	24.8	5.500	39.2	9.500	51.5
0.800	15.0	2.400	25.9	6.000	40.9		
1.000	16.7	2.600	26.9	6.500	42.6		

APPENDIX F

Flood Volume Displacement Calculation

There are 5 No units covering an area of 9.92m x 31.15m
The perimeter is made up of 0.3m thick external walls (labelled A, B, C, and D).
Supporting the 5 units are 4 internal walls of 0.215m thickness with 30% voids (labelled B, e, f, g, and h).
The ground levels range from 5.69m AOD to 5.90m AOD across the units' footprint.
The critical flood depth is 6.96m AOD.

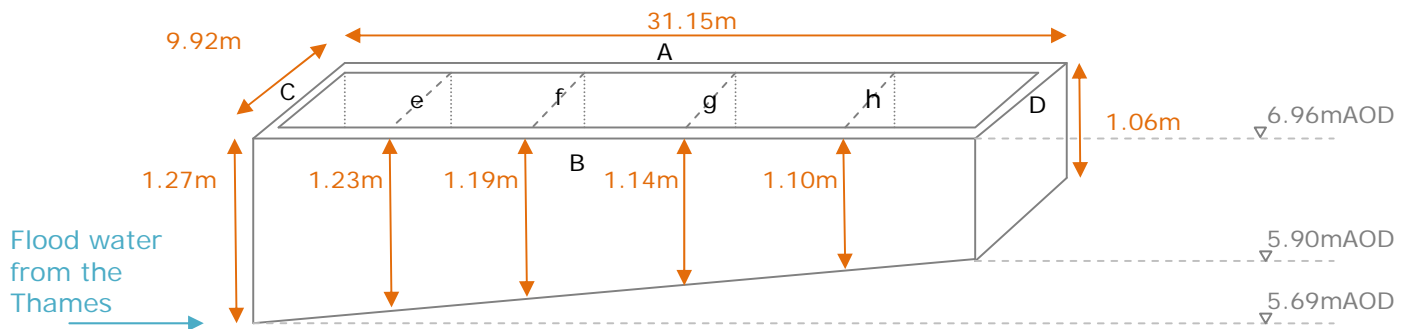

There is the width across the walkway in addition to this volume – see drawing ref 12-143 D(27) A-17 in Appendix C. The plan dimensions are 40.9m x 2.33m = 95.30m².

The flood volume of the external walls:

Volume of wall A: $0.5 \times (1.27\text{m} + 1.06\text{m}) \times 31.149\text{m} \times 0.3\text{m} = 6.30\text{m}^3$

Volume of wall C: $1.27\text{m} \times 9.315\text{m} \times 0.3\text{m} = 3.55\text{m}^3$

Volume of wall D: $1.06\text{m} \times 9.315\text{m} \times 0.3\text{m} = 2.96\text{m}^3$

Sub-total = 12.81m³

The flood volume of the internal walls:

Volume of walls B, e, f, g, h: $(1.23\text{m} + 1.19\text{m} + 1.14\text{m} + 1.10\text{m}) \times 9.315\text{m} \times 0.215\text{m} \times 0.7$ negative void ratio +
Wall B: $1.16\text{m} \times 32.1 \times 0.215 \times 0.7$ negative void ratio

Sub-total = 14.59m³

Therefore, the total displaced volume = 27.4m³

To compensate for the 27.4m³ volume of flood water displaced by external and internal walls, the ground within the floodable void must be lowered:

The internal void area = $308.84\text{m}^2 + 95.3 = 404.14$

$$\Rightarrow 27.4\text{m}^3 / 404.14\text{m}^2 = 0.07\text{m}$$

The floodable void ground level must be lowered by an average of **0.07m**.

W:\Projects\5228 FRA, M and M, 2 sites on Bucklands Road, Teddington TW11 8SQ\2.3 Specifications & Reports\F. Flood Risk Assessments	Date March 2014	Job No. 5228/2.3F
---	--------------------	----------------------

APPENDIX G

Flood Warning & Evacuation Plan

A permanently affixed durable sign shall be affixed adjacent to the electrical distribution board in each unit on Site A.

Its letters shall be no less than 3mm high in a simple, clear font and the lettering shall be black on a white background or white on a black background for maximum contrast.

Each sign should read:

Flood Warning

This building is at high risk of flooding.

The site is liable to flood only in the most extreme of storm events. This means that you may be forced to remain here until the flood waters recede.

You are strongly advised to sign up to the Environment Agency's (free) flood warning system, 'Floodline Warnings Direct'. This is explained on the EA's website: <http://www.environment-agency.gov.uk/homeandleisure/floods/38289.aspx>. You should also monitor the weather and keep informed of storm/flood developments as they arise. You are advised to keep informed by listening to the radio or watching the TV news bulletins.

Evacuation

Well in advance of any such threat you should plan ahead. Consider who you can visit (friends/family), further away from the coast. You should also plan the means of transport, e.g. by car, walking or other means.

If there are any occupants with physical disabilities then these should be incorporated into this plan.

The site may flood prior to you evacuating: you should ensure that you have sufficient provisions (food and sanitary/ cleaning materials etc.) for at least 3 days.

W:\Projects\5228 FRA, M and M, 2 sites on Bucklands Road, Teddington TW11 8SQ\2.3 Specifications & Reports\F. Flood Risk Assessments	Date March 2014	Job No. 5228/2.3F
---	--------------------	----------------------