

1 PLAN  
TYPICAL FACADE DETAILED DRAWING 1  
1:20



2 PLAN  
TYPICAL FACADE DETAILED DRAWING 2  
1:20

**Revisions**

PO1	14.07.16	ADDITIONAL PLANNING INFORMATION	AP	LP
PO2	13.01.17	PLANNING AMENDMENT SUBMISSION	NH	LP

**PLANNING AMENDMENTS**

- A GENERAL AMENDMENTS TO THE SOUTH END.
- A1 INCREASED SHINGLES CLADDING AREA AND CURTAIN WALL REDUCED ACCORDINGLY.
- A2 REDUCED MASSING AND REVISED INTERFACE WITH THE SOUTH STAND.
- B PPC LOUVRES LOCATED TO THE BOWL SIDE HAVE BEEN OMITTED.
- C CURTAIN WALL SETTING OUT REVISED GENERALLY. SILICONE JOINTS TO TRANSOMS AND MULLION REPLACED WITH CAPES SYSTEM LEVEL. PPC LOUVRES SETTING OUT A HEIGHT REVISED. MONORAIL FOR ROOFING REMOVED.
- D GENERAL AMENDMENTS TO THE CENTRAL ELEVATION CANOPY AT LEVEL SA REVISED GENERALLY AND STANDING SEAM REPLACED WITH SINGLE PLY MEMBRANE SUPPORT COLLING TO ROOF GANTRY REVISED. SQUARE FASCIA TO ROOF EDGE LEVEL SA GLAZED GIBBS EXTENDED IN HEIGHT AND PPC LOUVRES INCLUDED AT LOW LEVEL.
- D1 INCREASED SHINGLES CLADDING AREA AND CURTAIN WALL AREA REDUCED ACCORDINGLY. FOUR VERTICAL FINS REMOVED.
- D2 PORCELAIN PANELS WITH SLOTTED HOLES FOR VENTILATION REPLACED WITH PPC LOUVRES EXPRESSED HORIZONTAL PATTERN TO PORCELAIN PANELS OMITTED.
- D3 GENERAL AMENDMENTS TO THE NORTH END PORCELAIN CLADDING REPLACED WITH PPC ALUMINIUM CLADDING.
- E ALUMINIUM CLADDING REPLACED WITH PPC GREEN WALL TO THE NORTH END EXTENDED AND PPC LOUVRES REMOVED.
- E1 INCREASED SHINGLES CLADDING AREA AND CURTAIN WALL REDUCED ACCORDINGLY.
- E2 FENCELINE, GATE AND PERIMETER COLUMNS SETTING OUT REVISED.
- E3 CANOPY TO TURNSTILES REVISED.
- F PORCELAIN PATTERNS CHANGED FROM HORIZONTAL TO VERTICAL.
- F1 PORCELAIN PANELS TO THE SOFFIT OF THE ARCH REPLACED WITH PPC ALUMINIUM PANELS. PORCELAIN PANELS SETTING OUT REVISED.
- G GLAZED SPANDREL PANELS REPLACED WITH METAL SPANDREL PANEL. PORCELAIN PANELS REPLACED WITH PPC ALUMINIUM CLADDING.
- K PPC LOUVRES INCLUDED FOR MECHANICAL VENTILATION.
- L1

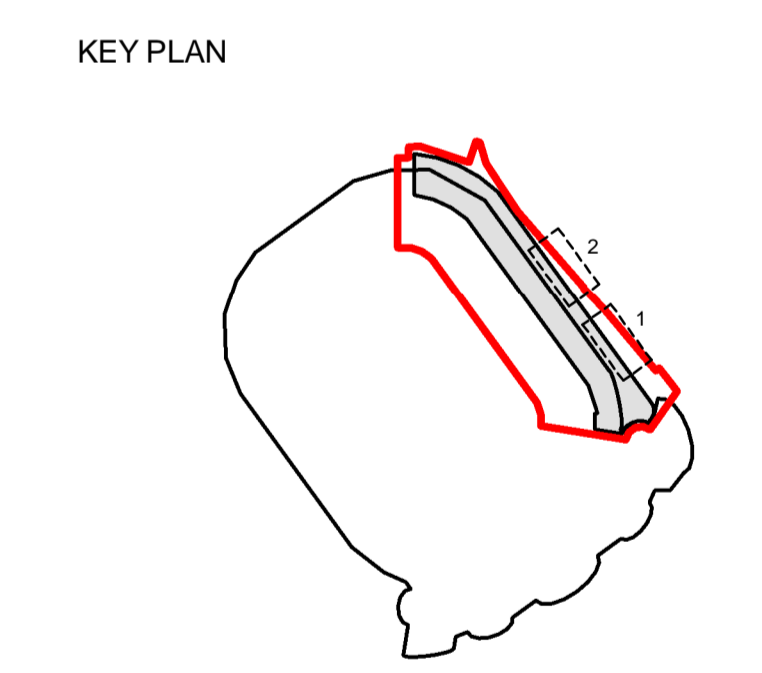

**PLANNING**  
Client: RFU  
Project: TWICKENHAM STADIUM EAST STAND EXTENSION  
Drawing title: TYPICAL FACADE CURTAIN WALL

**KSS** Scale of 1:1  
As indicated  
East Stand Extension  
Drawn by: [blank] Date shown: [blank]  
London: 1 James Street, London W1U 1DR  
T: 44(0)20 7907 2222 F: 44(0)20 7907 2299  
Sevenside: 7 Bight Walk, Sevenside TN13 1DB  
T: 44(0)20 7907 2222 F: 44(0)1752 407 841  
AP 09.03.17  
Checked by: [blank] Date checked: [blank]  
LP 09.03.17  
Doc ref: 100-KSS-DR  
Project number: 15735  
Drawing number: 240  
Revision: P02