

Energy Assessment

Produced by

Derek GC White



PROJECT:	Churchview Road TW2 5BT
CLIENT:	UK & European Property Developments Limited
PROJECT REF:	128_Churchview Road TW2 5BT
LOCAL AUTHORITY:	London Borough of Richmond upon Thames
BUILDING REGULATIONS:	Part L1a (2013)
ENERGY REDUCTION:	35%
DATE:	21 June 2017

Contents

1.0 - Introduction	2
2.0 - Executive Summary	3
2.0 - Renewable Energy Requirements	4
3.0 - Energy Hierarchy	5
4.0 - Methodology	7
4.1 - Energy Assessment	7
4.2 - Renewable Energy Options Appraisal	10
WIND TURBINES	10
SOLAR HOT WATER	11
SOLAR PV (Photovoltaic)	11
HEAT PUMPS	12
4.3 - Possible Options for Churchview Road TW2 5BT	16
4.4 - Preferred options for Churchview Road TW2 5BT	18
5.0 - Sustainable Development	18
6.0 - Conclusions	20

1.0 – Introduction

This report will investigate the various options for the provision of decentralised and renewable or low carbon energy sources (LZCs) in relations to the proposed development at Churchview Road TW2 5BT. It will discuss the appropriate options available to meet London Borough of Richmond upon Thames requirements

This Energy Assessment follows the guidelines set out in the Lord Mayor's Energy Strategic Specifically the document [ENERGY PLANNING](#)

[Greater London Authority guidance on preparing energy assessments \(March 2016\)](#)

The project will create 3 mews houses, 2 x end terrace and 1 mid terrace, each one having 2 bedrooms, a rear first floor terrace, an integrated car space and a mansard roof



2.0 – Executive Summary

	Regulated Carbon dioxide savings	
	(Tonnes CO ₂ per annum)	(%)
Savings from energy demand reduction	0.40	7.87%
Savings from CHP (only if > 300 units)	n/a	n/a
Savings from renewable energy	1.60	31.31%
Total Cumulative Savings	2.00	39.19%
Local Authority Target Savings		
	1.65	35.00%
London Plan Zero Carbon Target (since October 2016)	5.10	100.00%
Annual Surplus	-3.10	Against Zero Carbon

Table 2: Regulated carbon dioxide savings after each stage of the energy hierarchy

London Plan requires shortfall to be reported in tonnes of CO ₂	Annual Shortfall (Tonnes CO ₂)	Cumulative Shortfall (Tonnes CO ₂ over 30 years)
Shortfall	3.10	93.11

Table 3: Shortfall in regulated carbon dioxide savings

London Plan identifies October 2016 as date at which Zero carbon target to be achieved	LA Price per Tonne (London Plan default £60)	Total Carbon Offset Payment to LA
Not implemented by Local Authority	£ 60.00	£ 5,586.72

Table 4: Carbon Offset calculations

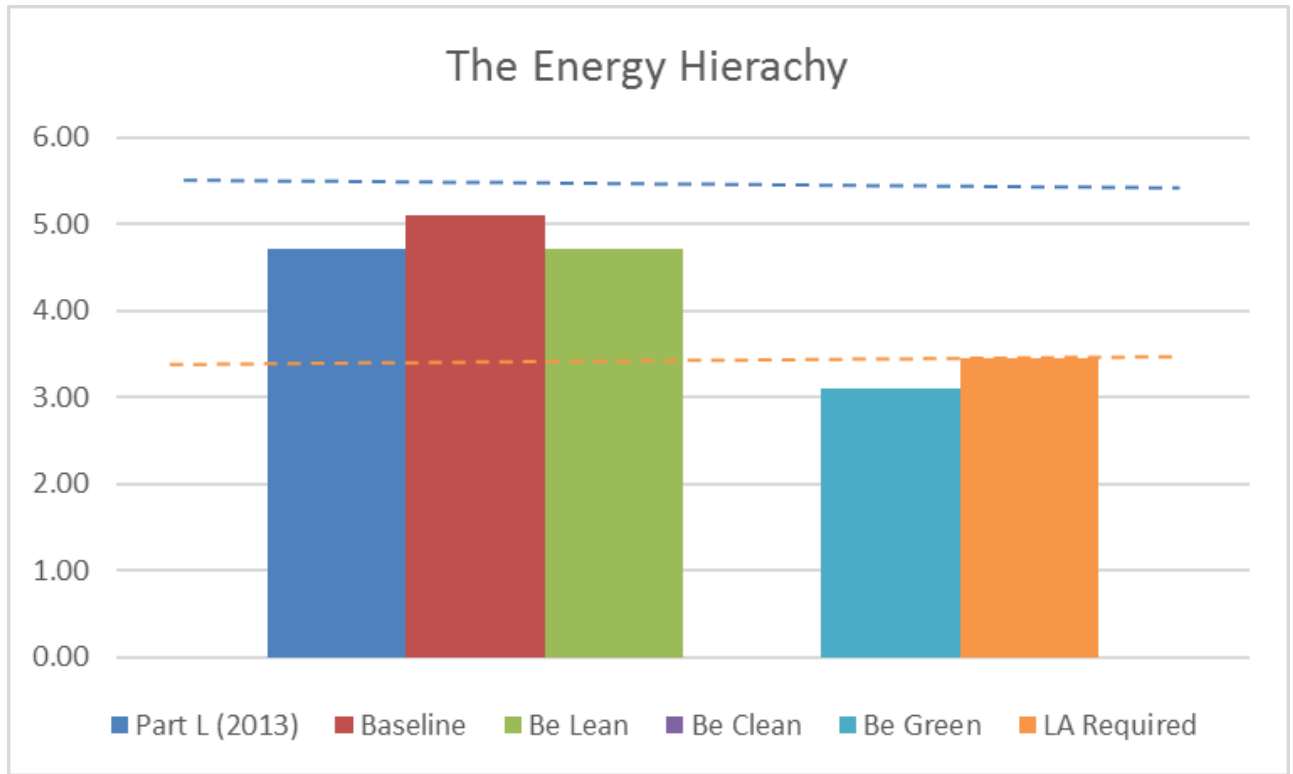

3.0 - Energy Hierarchy

When designing a building, it is advisable to follow an energy hierarchy. The primary aim is to make the building as energy efficient as possible to reduce the demand for energy, and thus the demand of energy from renewable sources.

Building Regulations Part L (2013) aims to reduce CO₂ emissions from new buildings by 8% compared to those built to 2010 regulations. This can be achieved by making improvements to the fabric of the building by increasing levels of insulation, increasing air tightness, addressing thermal bridging issues and the use of efficient heating & appliances. CO₂ emissions can be further reduced by using renewable energy sources.

To reduce by 35% the carbon emissions of the proposed development, the principle is to follow the energy hierarchy

- Be Lean – create an energy efficient building
- Be Clean – address the heating infrastructure
- Be Green – include Low or Zero Carbon (LZC) technology to further reduce the efficiency

Be Lean

The largest proportion of energy demand of a typical house is from space and water heating.

Areas of consideration to improve the efficiency of the fabric of a dwelling:

- Increased insulation to main external elements (roof, walls, floor, openings)
- Increase the efficiency of openings (windows, doors, etc.)
- Reduced thermal bridging
- Improved air tightness

Other areas for improvement:

- Improved heating & lighting controls
- Controlled ventilation
- Energy efficient lighting
- Energy efficiency applications (Cooker, washing machine, fridges, etc.)

By decreasing the total energy demand first, the 35% requirement to be secured from decentralised and renewable, or low carbon sources is also reduced. This could therefore mean a smaller renewable or low carbon unit is required that would not have produced the required 35% had these efficiencies not been made

Be Clean

Address the heating infrastructure looking at community heating systems and various heat pumps

Be Green

Include renewable energy sources to further reduce the CO₂ emissions.

What are Renewable Energy Sources?

Renewable sources of energy are those which are continually available in the environment. Examples of renewable energy sources are Solar Radiation, Wind, Hydropower, Geo-thermal and biomass.

Up until now the UK has produced most of its energy needs from the burning of fossil fuels (coal, oil, natural gas). This has led to the depletion of these resources as well as to the production of vast quantities of greenhouse gases, created as these fuels are burnt to provide energy. Renewable energy sources emit no greenhouse gases, or in the case of biomass are considered as carbon neutral over their lifecycle.

Energy efficiency first

Before any renewable technologies are considered it is good practice to reduce the overall energy demand of a dwelling by using low energy design techniques.

Low energy design involves the consideration and implementation of measures that will reduce the energy requirement of a dwelling. This can be achieved by:

- Improving levels of insulation and Reducing the level thermal bridging to reduce heat loss through the fabric of the building
- Use of low-energy technologies, e.g. low-energy lighting, energy efficient boilers & appliances.
- Use of passive solar design.

4.0 - Methodology

Energy Assessment

This report will use the Standard Assessment Procedure (SAP or SBEM) as a tool to demonstrate energy requirements for the proposed development. This will give an accurate assessment of the individual dwelling including its size, location and orientation to assess the total energy demand of the development.

SAP (or SBEM) assessments are done on individual dwellings. Energy usage and reduction for each unit will be calculated and the results summed to provide a site total. These calculations will be performed for each of the models

Renewable Energy Options Appraisal

Decentralised and renewable, or low carbon technologies will be discussed, with a view to securing a reduction of 35% of the total carbon emissions the development to satisfy the requirements of London Borough of Richmond upon Thames. The advantages and disadvantages for each option will be explored to conclude the most suitable technologies for this development.

Feasible renewable technologies will be assessed in terms of their operational information and suitability. A synopsis will demonstrate the most suitable solutions for the development from a feasibility perspective.

4.1 - Energy Assessment

SAP calculates the energy demand for heating, hot water, lighting, pumps and fans and this considers any reduction in energy use from built form by considering solar gains and efficiency measures such as lighting, insulation and choice of boiler. As considered good practise, the energy requirement of appliances & cooking has been calculated by increasing overall energy use by twenty percent

Stage 1 - Baseline

The development is modelled so that it meets the minimum requirements of Part L1a (2013) using the Table 2 Limiting fabric parameters (from the Part L1A manual) increasing the efficiency of the various elements, where appropriate

Stage 2 – Be Lean

Another model is developed that increases the thermal efficiency of the development, as a minimum, to those detailed in Table 4 Summary of concurrent notional dwelling specifications, from the Part L1A manual

Stage 3 – Be Clean

Review the heating infrastructure and assess the impact of various alternative heating systems

Stage 4 – Be Green

In required, include LZC technology to ensure there is a reduction of 35% of CO₂ emissions

Table 4.1 – Baseline: Part L (2013) of the Building Regulations compliant development

Average DER values for the development	Space heating demand (kWh/yr)	Water heating demand (kWh/yr)	Energy use for fans / pumps (kWh/yr)	Lighting	Total before Cooking / Appliances (kWh/yr)	Unregulated (kWh/yr) (+15% assumed)	Total energy use (kWh/yr)
20.51	2,982.87	1,422.39	116.78	581.81	5,103.84	765.58	5,869.41

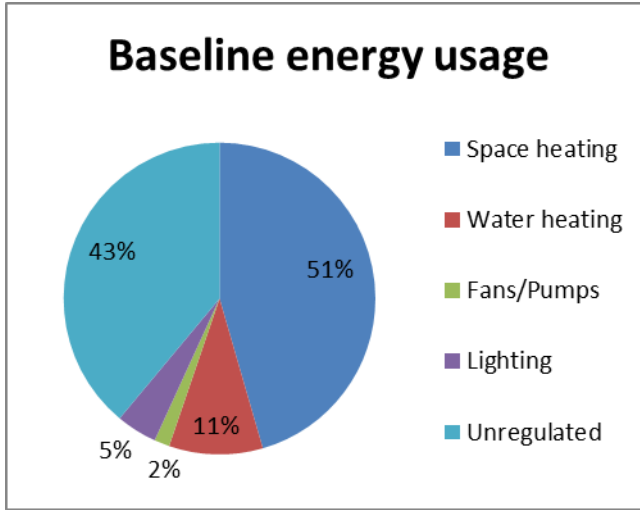

How this development utilises energy

Figure 4.1 Breakdown of Baseline energy use

Table 4.2 - After energy demand reduction

Average DER values for the development	Space heating demand (kWh/yr)	Water heating demand (kWh/yr)	Energy use for fans / pumps (kWh/yr)	Lighting	Total before Cooking / Appliances (kWh/yr)	Unregulated (kWh/yr) (+15% assumed)	Total energy use (kWh/yr)
19.03	2,579.15	1,424.20	116.78	581.81	4,701.93	705.29	5,407.22

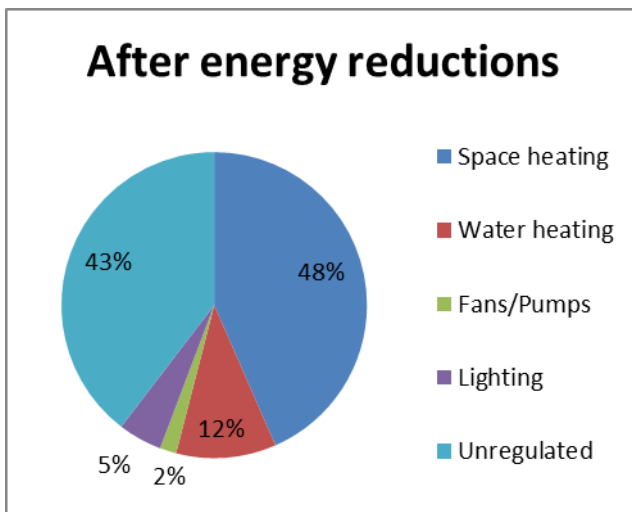

After energy efficiency savings, have been made to the fabric of the building

Figure 4.2 Breakdown of energy use after energy demand reduction

Table 4.3 – After addressing the heating systems

This development is too small to utilise Combined Heat and Power (CHP) and no other practical heating systems offers further energy reductions, See below for the details

Table 4.4 - After including renewable energy systems

Average DER values for the development	Space heating demand (kWh/yr)	Water heating demand (kWh/yr)	Energy use for fans / pumps (kWh/yr)	Lighting	Total before Cooking / Appliances (kWh/yr)	Unregulated (kWh/yr) (+15% assumed)	Total energy use (kWh/yr)
16.15	2,559.74	1,424.19	116.78	581.81	4,682.52	702.38	5,384.89

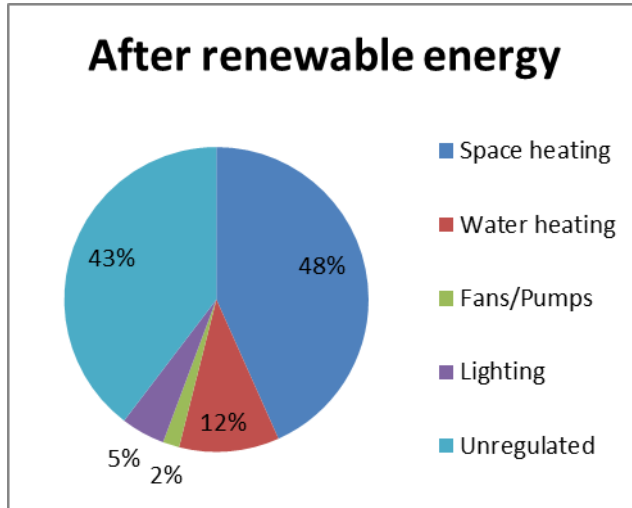

Energy usage profile after low or zero carbon technology has been added to the development

Figure 4.4 Breakdown of energy use after including renewable energy systems

4.2 - Renewable Energy Options Appraisal

The following demonstrates the various energy systems which have been considered in relation to their sizing, potential contribution to the site and practical constraints of including the technologies, which could be applicable to this development

The following renewable and low carbon source energy systems will be considered:

- Wind turbines
- Solar thermal hot water
- Solar PV (photovoltaics)
- Heat pumps (Air/Ground/Water Sourced - ASHP/GSHP/WSHP)
- Biomass

WIND TURBINES

The UK has the largest potential wind resource in northern Europe with approximately 40 per cent of the total supply available and this potential is recognised by the UK, Government, which sees wind energy as making a significant contribution to its renewable energy target of supplying 10% of total energy requirement by 2010

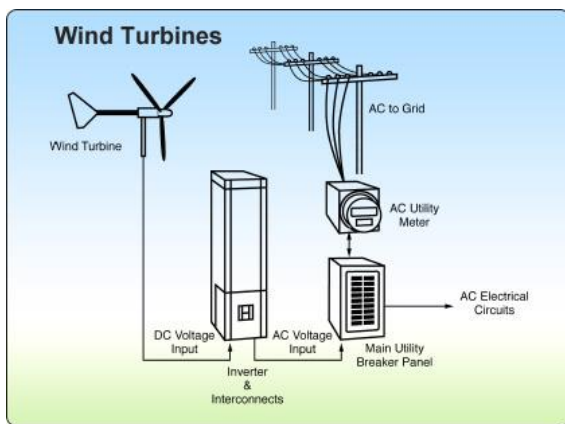

Wind turbines can have outputs ranging from a few watts to several megawatts and produce electricity without emitting CO₂. Energy is extracted from the wind using a rotor generally consisting of two or three blades, which have a profile like that of an airplane wing. If the diameter of the rotor is doubled, the power output from the turbine is quadrupled at a given wind speed.

Correct assessment of the resource and siting is critical before considering the installation of a turbine. Potential sites should generally have average wind speeds of greater than 5m/s at hub height to be economically viable in the UK,

although small roof mounted wind turbines (typically up to 1.5kw) can function at wind speeds as low as 3.5m/s. Wind energy availability varies on a seasonal basis, peaking during the winter months, which matches well with the requirements in a development

Although best suited to becoming increasingly opportunity to connect them directly in a dwelling. For their output will be affected. rooftop mounted turbines are becoming increasingly available, where the higher average wind speeds at increased hub heights contribute to improved performance.



rural environments, modern wind turbines are cost effective in low density areas where there is often the immediately to the grid, or use the electricity generated. higher density housing, they are not as cost-effective as by lower and disrupted average wind speeds. Rooftop

Building-mounted wind turbines have been considered for use on this site, as it would be possible to mount wind turbines on roof areas. The electricity produced could be used to provide a contribution of the energy requirements.

SOLAR HOT WATER

Solar thermal or solar hot water (SHW) systems for use in dwellings use a heat collector that is usually mounted on a roof. The collector contains a fluid (usually water with glycol) which is heated by the sun. The heated liquid is then passed through a coil in a hot water storage cylinder. The water in the cylinder may then be supplied directly, or raised to a higher temperature (if required) by a boiler or electric immersion heater. In this way the 'free' energy obtained from the sun can be used to offset the amount of Energy required for providing domestic hot water, and will reduce both running costs (due to the fuel being displaced) and the associated CO₂ emissions. These systems do not generally provide space heating and are among the most cost-effective renewable energy systems that can be installed on dwellings in rural or urban environments.

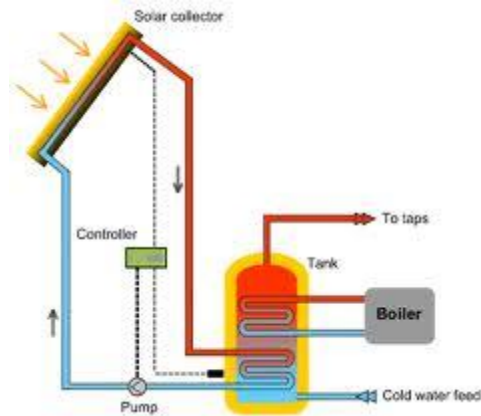

Evacuated tube system

Solar thermal systems can be linked to a GSHP/ASHP to offer maximum hot water provision from the energy used. Typically, this will provide a proportion of the hot water demand for the dwelling over the course of a year dependent on external conditions and deliver 1400– 2000kWh of useful heating energy a year, as follows:

Summer	50% - 60%
Spring/Autumn	40% - 30%
Winter	15% - 25%

Solar thermal systems require large cylinders (around 150 litres in addition to any thermal store normally associated with system boilers), plus there will



need to be pipework running from each tank to the solar panels on the roof. For a multi dwelling building these pipe run will be a source of heat loss and therefore efficiency loss

SOLAR PV (Photovoltaic)

PV systems convert energy from the sun into electricity via semi-conducting cells. A cell consists of a junction between two thin layers of dissimilar semiconducting materials (usually based on silicon). When light shines on the junction, a difference in energy is created - known as "potential difference" or "voltage". This voltage is used to produce an electrical current (direct current - DC) which can be used directly or converted into alternating current (AC) depending on the application. AC is the

most appropriate for domestic use and for exporting to the local electricity network or national grid.

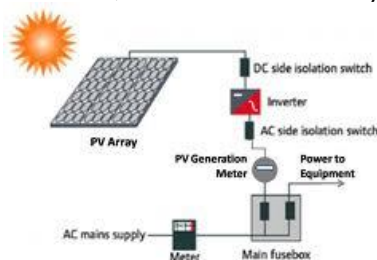

The brighter the light, the more power is produced by the cells - although PV cells still produce power when the sun is hidden by clouds.

(nearby buildings, trees) is a key produce a drop in output than be oriented as close to south as the day.



However, shading from other objects issue with PV – they are more likely to solar thermal panels. Ideally panels should possible, and be without shade for most of

Individual PV cells produce only

a small amount of power and so are



connected together to form modules, which are then linked to form an array which is sized depending upon the energy required. Current research suggests that a PV panel less than 0.53 kWhp becomes increasingly less able to function so use of minimum of 0.60 kWhp, per dwelling, will be considered

There are three main types of solar cells available in the UK:

Monocrystalline

Very thin wafers of silicon cut from a small seed crystal. This is the most efficient and most expensive option due to the manufacturing process.

Polycrystalline

Instead of one crystal, several different crystals are used in slice production. The result is cheaper PV cells than monocrystalline but with lower efficiencies.

Amorphous silicon

Silicon is made into a continuous strip of film Cells can be produced more quickly and hence cheaply. This option is cheaper than mono or polycrystalline, but with substantially lower efficiencies.

A variety of solar cells based on materials other than silicon, such as cadmium telluride (CdTe) and copper indium diselenide (CIS) are also starting to appear in the UK market, as they are easier and cheaper to manufacture.

Development in PV technology is increasing due to increased demand, which is decreasing costs as well as improving efficiencies. Solar PV cells are slowly becoming popular as these improvements in cost and efficiency are realised. A feed-in-tariff incentive scheme is now in place in the UK, making Solar PV a less costly option for the long term.

HEAT PUMPS

A heat pump works by extracting heat energy from a source and transferring that energy into a form that can be used for space heating (and/or hot water pre-heating in some cases). Heat pumps operate much like a refrigerator in that they 'pump' heat from the surroundings into an enclosed space, rather than extracting heat energy from the contents of the fridge and into the room.

There are two prominent types of heat pump available in the UK, Ground Source and Air Source.

Ground Source Heat Pumps (GSHP)

In the UK, at one metre below the surface, the earth maintains a constant temperature of around 11 °C throughout the year. Because of its high thermal mass, the ground stores heat obtained from the sun during the summer months.

Ground Source Heat Pumps can transfer this heat into a building to provide space heating and in some cases preheating domestic hot water. For every unit of electricity used to operate the system at least 3-5 units of heat energy are produced. This is known as the Coefficient of Performance (COP).

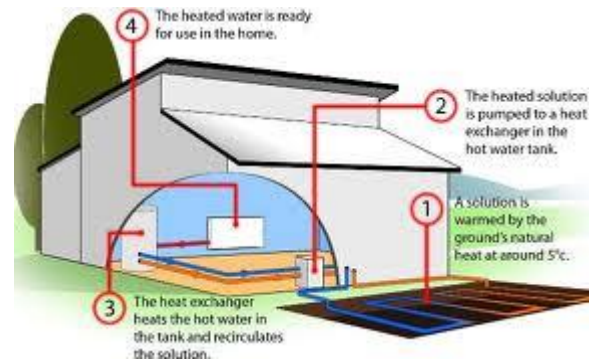

How does GSHP work?

There are three important elements to a GSHP:

Ground loop

The ground loops are laid either horizontally



or vertically in boreholes



Heat pump

Comprises lengths of pipe buried in the ground, either vertically in a borehole (or series of boreholes) or horizontally in trenches (or sometimes in lakes and ponds). The pipe is usually a closed circuit and filled with a mixture of water and antifreeze, which is pumped around the pipe absorbing heat from the ground.

The hub of the system – much like a fridge or air conditioner, fluid is pumped around the system through a series of heat exchangers that extract the heat energy and transfer it to the distribution system.

Heat distribution system

Consists of underfloor heating (or occasionally oversized radiators) for space and in some cases water storage for hot water supply.



heating

Air source heat pumps (ASHP)

As the name suggests, ASHPs take energy from ambient air.

COP for ASHP ranges from 2.5 to 4, depending in the system used; SAP uses an assumed efficiency of 250% (COP 2.5) for ASHPs (i.e. the heat energy provided by the system is 2.5 times that of the energy used to power the system)

There are two main types of Air Source Heat Pumps:

Air to Water Heat Pump



A compact unit is fixed to the exterior of the house, most commonly the rear of the property, (the unit looks much like an air conditioning unit) which passes heated refrigerant (warmed by taking heat from the outside air) to an internal unit containing the cylinder, expansion vessel and electric heater. The internal unit raises the temperature to heat domestic hot water and water-based heating systems. Back up heating is provided by an integral electric heating.

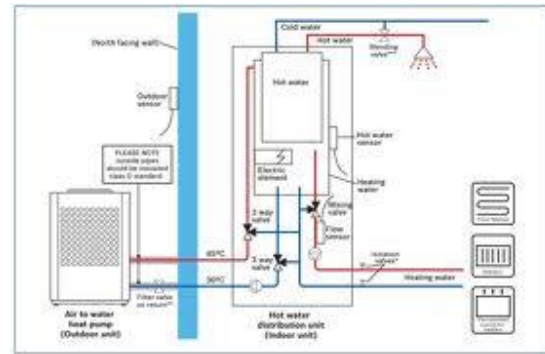

Exhaust Air Heat Pump



A mechanical ventilation system combined with a heat pump (MVHR), which extracts air via ductwork connected to the warm areas of the dwelling such as bathrooms, kitchens and utility rooms. Heat is removed from the air and transferred into the heat pump where the temperature is raised to heat the domestic hot water and provide space heating. Back up heating is provided by an electric heating unit integral within the system

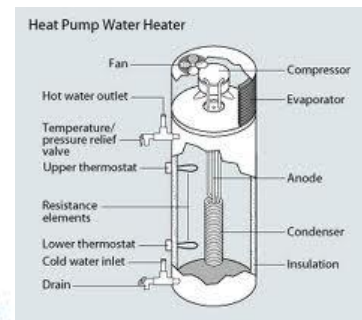

Water sourced heat pumps (WSHP)

As the name suggests, WSHPs are very similar to GSHPs but take energy from a large area of water such as a lake but otherwise they work in exactly similar way to Air Source Heat Pumps

BIOMASS



Biomass is the term used to define all plant and animal material and has been used as an energy source for centuries. Although there are several different technologies available that extract heat from biomass, wood burning systems are most likely to be appropriate for use in community systems.

Wood is an extremely versatile energy source which

can be burned in many different forms and numerous appliances. Burning biomass differs from other renewable energy sources in that CO₂ is emitted when it is burned to produce heat. However, the

quantity of CO₂ released is the same as the quantity of carbon absorbed by the tree whilst it was growing. Thus burning biomass is considered to be carbon-neutral.

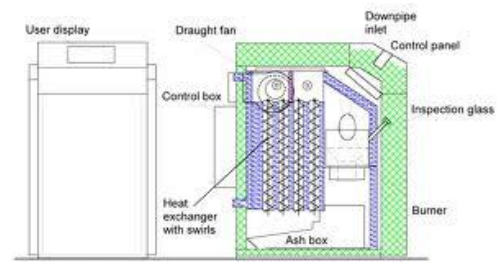

To be a true renewable energy source the wood (biomass) must come from a sustainable source (i.e. it is replenished when harvested) and have minimal secondary CO₂ emissions (e.g. extra CO₂ produced through transportation).

Wood fuel can be sourced in three main forms: logs, pellets and woodchips. Logs are a simple, cheap and quick way of using wood fuel, although the energy density of a wood log is half that of a wood pellet, and a quarter of that of woodchip.



Burning wood fuel on a large development would involve the use of large automatic wood chip/pellet boiler situated in a central energy centre with adjacent wood pellet store to supply the installation. Due to the slow response rates of these boilers a thermal store can be included in the installation to smooth demand requirements.

To minimize pollution, the boilers must have Individual flues designed to take the emissions above the surrounding buildings and ensure dilution of particulates and pollutive emissions. The pellet fuel supply must also be monitored for moisture and dust content.

On an individual dwelling basis biomass energy, can be obtained using a wood burner to burn wood logs, chips or pellets. It is even a desirable feature for some developments in a market where many prospective home owners would like a wood burner installed.

The following must be considered at the early stages of a project to ensure a successful biomass scheme:

- Fuel sourcing
- Delivery of the fuel to the central fuel store
- Fuel handling
- Boiler sizing and control
- Local Environmental Pollution

4.3 - Possible Options for Churchview Road TW2 5BT

It is important when considering a suitable solution to factor it into the design at an early stage, in order to integrate them fully into both the infrastructure of the site, as well as that of the layout, etc. of each dwelling type.

The following technologies are deemed not suitable:

- Wind Turbines
- Biomass
- WSHP

Wind Turbines

Due to the nature of the site, small scale wind turbines would not be considered as a viable energy source. It is viewed that the proximity of surrounding buildings would adversely affect the wind flow across the site and as such could not be considered a reliable or consistent energy source.

Wind turbines are well-suited to larger scale implementations and exposed (usually rural) locations where there is greater likelihood of a consistent wind flow.

Biomass

The burning of wood, whilst a good source of renewable energy, is not deemed suitable for this development for several reasons:

- Insufficient space within the smaller dwellings
- The wood burner would be considered as a secondary heat source to back up the primary heating system. It is not guaranteed that the wood burner would be used rather than a fossil fuel powered source, e.g. gas boiler, electric heater.
- In urban areas, attention should be paid to atmospheric pollution by smoke. Many urban areas (including the London Borough of Richmond upon Thames) are smoke control zones.
- The availability of sufficient quantities of fuel may be an issue due to site location.
- There is insufficient fuel storage space on site
- Design/construction constraints of installing flues/chimneys

Water Sourced Heat Pumps

There is no suitable water source within the grounds of this development

Further Options

The following technologies should be scrutinised further:

- Heat pumps
- Photovoltaic cells

Heat Pumps

Heat pumps are an effective means of producing renewable energy and are a good low-carbon energy source. However, heat pumps use electricity for their power source, which is considered to have a larger CO₂ footprint than that of alternatives such as gas or zero-carbon sources such as biomass

In terms of CO₂ emissions, it is generally accepted only GSHP would achieve a reduction in CO₂ emissions greater than 20% reduction

Whilst this method is theoretically practical on a development of this size and scale the areas of the garden (<100m²) is insufficient for the both the underground pipework or necessary units

Typically, two trenches of 225–300m would be required for a development of 45 kW heat loss (Heat Pump Association – Heat Pump Data sheet). A geological survey may identify the potential for 50 – 100m boreholes however; the cost implications of either option is likely to make the development unviable

WSHP are dependent upon a constant large volume of water accessible from the development in question and will therefore be unlikely to be feasible on Urban and Suburban location

Photovoltaic Cells

There is a flat roof on this development that would make siting the cell easy and out of site from most pedestrians

PV cells may be installed per dwelling or may be allocated to flats by floor area providing more flexibility and provide the necessary reduction in CO₂ emissions

NB. The CO₂ emissions reduction is dependent on site specific variables, e.g. heat loss area, perimeter, volume, and so SAP calculations will be required to demonstrate emissions per dwelling to determine if a heat pump is suitable.

In summary:

- Photovoltaic cells are deemed suitable for this site
- Air Source Heat Pumps (ASHP) are deemed potentially suitable for this development especially if they are used as part of a communal heating system for the whole development
- Ground Source Heat Pump (GSHP) are deemed not suitable for this development due to the cost of installation. Also, there is insufficient space to install a viable pipe run to extract the required energy and, due to the size of the dwellings, a heat recovery unit the size of a fridge/freezer is inappropriate

4.4 - Preferred options for Churchview Road TW2 5BT

The preferred options for this site are:

- PV cells
- Air Sourced Heat Pumps

Air sourced heat pumps, upon further scrutiny show an increase in CO₂ emissions over a gas fire boiler even though they are inherently more efficient – mains electricity generate around 750 mg/kWh of NO_x emissions compared to a modern Gas boiler that produces around 40 mg/kWh also there is not suitable location for the inverters required

PV cells have the required space available on the roof of approximately 10.5 m² per unit

4.5 – Findings

	Carbon dioxide emissions (Tonnes CO ₂ per annum)	
	Regulated	Unregulated
Typical: Part L 2013 of the Building Regulations maximum allowable	4.72	0.77
Baseline: Part L 2013 of the Building Regulations Compliant Development	5.10	0.77
After energy demand reduction	4.70	0.71
After CHP (only applicable > 300 units)	n/a	n/a
After renewable energy	3.10	0.70

Table 1: Carbon Dioxide Emissions after each stage of the energy hierarchy

CHP is only applicable for larger development (around 300 dwellings or more)

It is expected that 1.25 kWhp of Solar PV cells – for units 1 & 3 and 1.5 kWhp of Solar PV – for unit 2 be installed to achieve the results above. At approximately 1.6 m² per 0.25kWhp panel, a maximum area of 10 m², per unit, is required to ensure the CO₂ emissions are reduced by 35%

5.0 - Sustainable Development

As stated in the introduction the need to reduce the energy use should always be the first option before considering renewable technologies. The scheme should therefore follow the energy hierarchy of first reducing consumption through energy efficient design, then the use of decentralised and renewable or low carbon sources.

Material selection is another key area of sustainable construction and where viable, materials from sustainable or managed sources, including PEFC, FSC, EMAS and EMS, will be used. One example of this is the use of lightweight aggregate blocks for the inner skin of the external wall. These are manufactured using up to 80% pulverised fuel ash (PFA), a by-product from coal burning power stations, which is both stable and environmentally friendly. Using these blocks helps to achieve an 'A' rating under the BRE 'green guide to specification' for the external wall construction. 'A' ratings are also achievable for the floors and roofs. In addition, we seek to use locally sourced materials, trades and business partners to minimise transport energy use.

Alongside energy efficiency, the dwellings could also incorporate measures to reduce the demand for water. This can be achieved by using low flow rate taps & showers, reduced capacity toilets and baths. The current requirement of the Code for Sustainable Homes levels 3&4 is that water demand is no greater than 105 litres per person per day and although the Code is being phased out internal water usage is very important

The following criteria could assist in producing a sustainable building:

- Fabric u-values: Walls < 0.18, Floors < 0.13, Roofs < 0.13, Glazing < 1.4
- Efficient (min 89.5%) condensing boilers
- Efficient thermal controls (zone control, weather compensation, etc.)
- Natural ventilation
- Low air permeability (less than 5m³/h/m² at 50pa minimum)
- Low energy and low water consumption appliances
 - Low energy lighting to 100% of the dwelling
 - Low capacity dual flush toilets (6/3 litre)
 - Low capacity baths (less than 140 litre)
 - Low flow rate showers (4.5litres/minute)
 - Low flow rate taps (2.5litres/minute) aerated with restrictors
 - Rainwater butts for external watering
 - The use of grey water recycling and rain water collection

6.0 - Conclusions

It has been concluded that, after the reduction in energy required for this development by increasing the thermal efficiency of the buildings fabric solar technologies are the best-suited LZC technologies for the development Churchview Road TW2 5BT.

Solar PV panels alone could provide the 35% reduction in CO₂ emissions required by London Borough of Richmond upon Thames on behalf of the Lord Mayor