

Supply Air Hood JSI-UV-Turbo

DISTRIBUTION OF SUPPLY AIR

Jeven supply air columns deliver a controlled and flexible distribution of the supply air.

It is possible to wash the supply air columns in a dishwasher and the inside of the supply air chambers is easy to clean.

These columns allow individual adjustment of air patterns and airflows, which means better indoor climate for the kitchen staff.

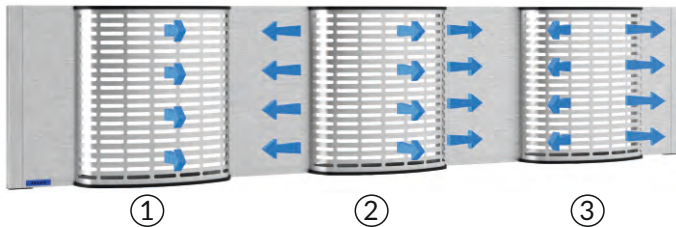

- ① Unidirectional thrown pattern
- ② Displacement thrown pattern
- ③ Bidirectional throw pattern

Supply air unit, Damper open

Sound attenuation, dB		Hz					
Hood height	Spigot	125	250	500	1000	2000	4000
330 mm	ø 200	17	10	10	11	18	24
	ø 160	24	8	5	12	17	24
540 mm	ø 160	24	8	5	12	17	24
	ø 250	16	9	7	11	16	23

LIGHTS

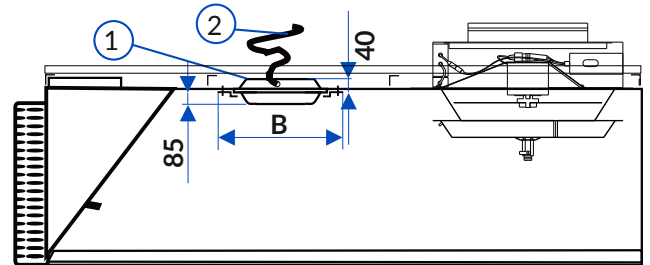

- ① Light fixture as standard, IP 54-67

T8:

B=111mm, (1x18W, 1x36W, 1x58W)
 B=168mm, (2x18W, 2x36W, 2x58W)

Colour temperature 840(Cool White)

- ② About 2m cable, type EKK 3x1,5

By default, every hood module comes with a light fixture. The light fixture has a cable which should be connected to a junction box with a cable lock. The junction box is not included.

Supply Air Hood JSI-UV-Turbo

ELECTRICAL AND AUTOMATION DESIGN GUIDELINES

HPAC designer defines to the plans the types and locations of the products to be wired.

Electrical designer defines to the plans the location of the safety switch, switchgear and wiring from the panelboard or kitchen switch to the safety switch.

Automation designer defines to the plans the running time of the UV-TurboSwing and it shall match to the running time of kitchen.

Safety switch is compulsory and it should be situated close to the hood and on the visible place in the kitchen.

The safety switch, appliance sockets and the cables marked with the broken line are not included in the Jeven delivery.

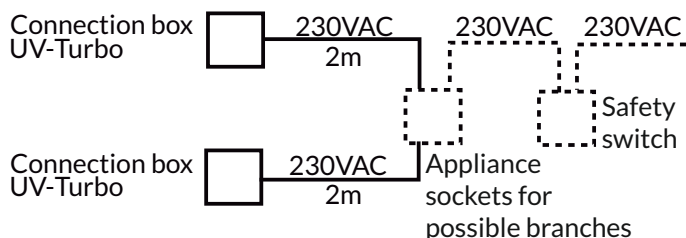

Wiring diagram

Products which need to be wired are placed to to HPAC plan.

Safety switch, switchgear and wiring from panelboard or kitchen switch to safety switch are placed to electrical plan.

Automation designer defines to the plans the running time of the TurboSwing shall match to the running time of kitchen.

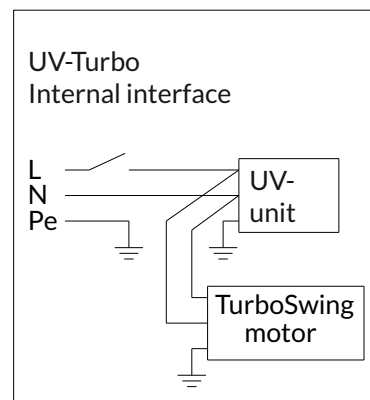

Project: Marble Hill
Quotation Reference: Q04879
Date: 12 Oct 2016

Customer Unit Reference	AHU-1	Serving	Supply AHU - Option 1
Unit Reference	Q04879-01-0		
Model Reference	AD31260		

AHU Details

Design Supply Air Volume	1.18	m ³ /s
External Static Pressure	150	Pa
Unit Velocity	1.53	m/s

Energy Use

	Supply on Clean Filters	Overall	
Specific Fan Power	0.56	0.56	kW/(m ³ /s)

AHU Construction

Framework	30 mm
Framework Coating	Anodised
Panel Depth	25 mm
External Panel Finish	GWG Plastisol with film 0.9mm
Internal Panel Finish	Galv Sheet 0.9mm
Panel Insulation	Mineral Wool 25mm

Construction

Unit Location	External
Weather Roof	Flat Roof
Baseframe	100 x 50 PFC
Leakage Class	No specification

Overall Unit Dimensions

Length	Width	Height	Weight (Per Unit)
2310 mm	1240 mm	710 mm	441 kg

Section Weights and Dimensions

Section No.	Length	Width	Height	Weight Approx +/-5%
A	2310 mm	1240 mm	710 mm	441 kg

Inlet Section

Component	Damper - Louvre
Air Pressure Drop	8.00 Pa

Construction

Casing	Aluminium
Control	Extended Spindle

Accessories

Damper actuators to be provided and fitted by others.
 Traffolyte Component label

Panel and Bag Filter

Panel Clean PD	43	Pa
Panel Mean	97	Pa
Panel Recommended Dirty	150	Pa
Bag Clean PD	53	Pa
Bag Mean	126	Pa
Bag Recommended dirty	200	Pa

Construction

Panel Grade	G4 (EN779:2012)
Panel Media	Card Frame-Cotton/Synthetic Media
Panel Size 1 / Qty	2 x 595 x 595 x 47 mm
Bag Grade	F7 (EN779:2012)
Bag Media	25mm Galv Frame/Glass Fibre
Bag Size 1 / Qty	2 x 595 x 595 x 635mm

Accessories

Factory fitted Pressure Differential Tappings either side of the filter.
 Traffolyte Component label

Project: Marble Hill
Quotation Reference: Q04879
Date: 12 Oct 2016

Customer Unit Reference	AHU-1	Serving	Supply AHU - Option 1
Unit Reference	Q04879-01-0		
Model Reference	AD31260		

Supply Fan - Single Fan			Construction	
Design Air Volume	1.18	m ³ /s	Impeller	Backward Curve
Total Fan Resistance	432	Pa	Internal Isolation	Rubber
Fan Speed	1826	r/min		
Frequency @ Design Speed	43.50	Hz		
Max Frequency	50.0	Hz		
Maximum Fan Speed	2100	r/min		
Efficiency	59.16	%		

Motor Data			Construction	
FLC	1.90	Amps	Type	EC
Total Input Power	0.86	kW		
Motor Power	1.35	kW		
Motor Speed	2100	r/min		
Electrical Supply	400/3/50			

Accessories

Fan Healthy Contacts (For integration in to the controls system)
 Traffolyte Component label
 Traffolyte Warning label - Fan run down
 Traffolyte Danger label - Safety
 Traffolyte Warning label - Electrical Isolation
 The fan motor will be wired with screened cable to an externally mounted IP66 rated isolator.

Access Section

Length	400	mm
Access Side	Right	

Accessories

Traffolyte label - Access

Heating Coil

Heating Coil			Construction	
Air On / Off	-5.0/20.0	°C/°C	Casing Material	Galvanised
Duty	35.74	kW	Tube Material	Copper
Water(Inlet)/(Outlet)	80.0/60.0	°C/°C	Fin Material	Aluminium
Water PD	14	kPa	Connection Size	1 x 1"(F) / 1 x 1"(R)
Water Flow Rate	0.44	L/s		
Air Pressure Drop	10.00	Pa		

Accessories

Valve and actuator to be supplied and fitted by others
 Traffolyte Component label

Outlet Section

Outlet Section			Construction	
Component	Spigot		Casing	Not Applicable
Air Pressure Drop	0.00	Pa	Control	Not Applicable

Project: Marble Hill
Quotation Reference: Q04879
Date: 12 Oct 2016

Customer Unit Reference	AHU-1	Serving	Supply AHU - Option 1
Unit Reference	Q04879-01-0		
Model Reference	AD31260		

AHU Acoustic Data:

Acoustic Data (Supply Fan Sound Power Level):

Frequency(Hz)	63	125	250	500	1K	2K	4K	8K
Supply Fan Inlet Lw (dB):	71	72	76	74	67	62	60	58
Supply Fan Outlet Lw (dB):	71	73	78	78	77	70	66	60

Acoustic Data (Supply AHU Sound Resultant Level):

Frequency(Hz)	63	125	250	500	1K	2K	4K	8K
Supply AHU Inlet Lw (dB)	68	68	72	69	61	54	49	46
Supply AHU Outlet Lw (dB)	69	71	76	76	74	65	56	50

Resultant AHU Breakout

Frequency (Hz)	63	125	250	500	1K	2K	4K	8K
Supply Lw (dB)	63	64	64	51	49	42	39	34
Resultant AHU Level @ 3m	45	46	46	33	31	24	21	16
Overall AHU "A" weighted Breakout @ 3m	39							

The In-duct Sound Power Level Spectra are in dB re-1pW.

The overall A-weighted sound pressure level is at a distance of 3m with spherical free-field propagation. It is expressed in dB re-20 µPa and is presented for comparative purposes only.

Resultant sound pressure includes all selected AHU component losses within the above calculation.

Unit Height including base 810mm

Unit Width 1240mm

Section A: Weight = 441Kgs

- Components
- 1 Inlet
 - 2 Panel & Bag Filter
 - 3 Plug Fan
 - 4 Access
 - 5 Water Heating Coil
 - 6 Outlet

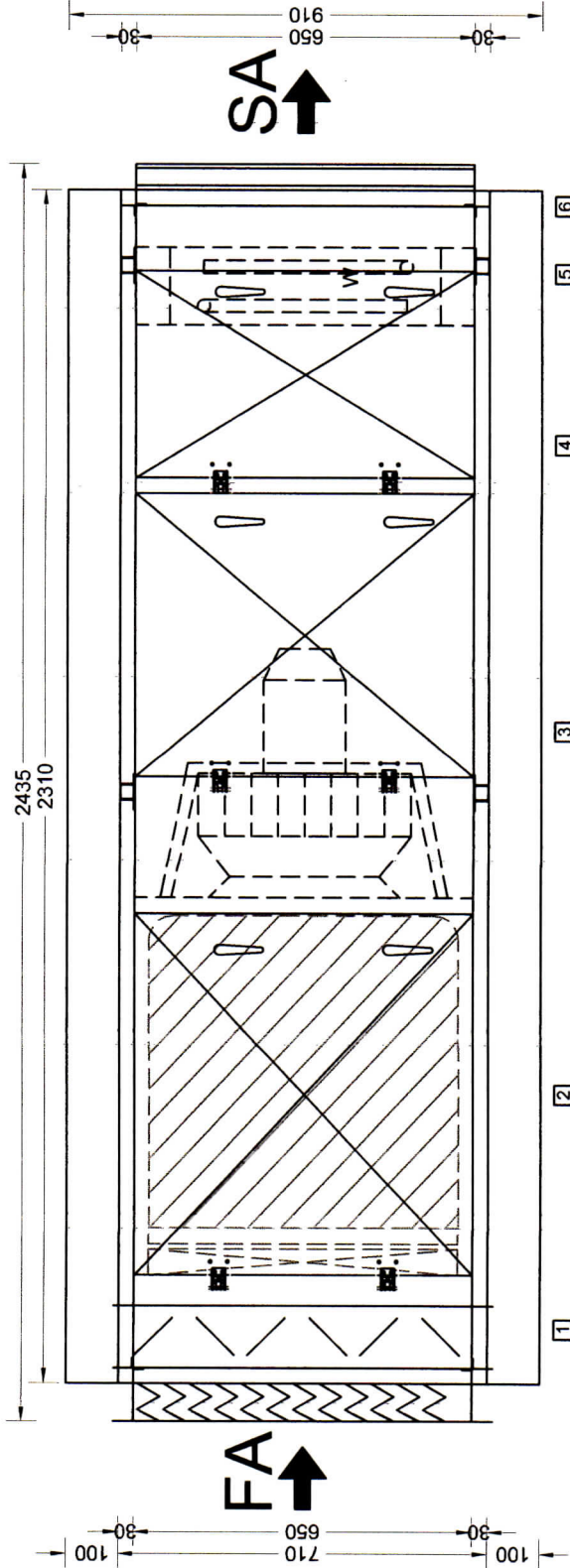

ELEVATION

AIRDESIGN (UK) LTD UNIT 46, PENSNETT TRADING ESTATE, KINGSWINFORD, WEST MIDLANDS, DY8 7JUS T: +44 (0) 1384 275760 F: +44 (0) 1384 275810 E: SALES@AIR-DESIGN.COM	Project	: Marble Hill	Project ref	: 04879-1-0	Date	: 12 Oct 2016
	Unit reference	: Supply AHU - Option 1	Unit number	: 04879	Title	:
	Number off	: 1	Revision	: 0	Not to scale	

Unit Height including base 810mm

Unit Width 1240mm

Section A: Weight = 441Kgs

- Components
- 1 Inlet
 - 2 Panel & Bag Filter
 - 3 Plug Fan
 - 4 Access
 - 5 Water Heating Coil
 - 6 Outlet

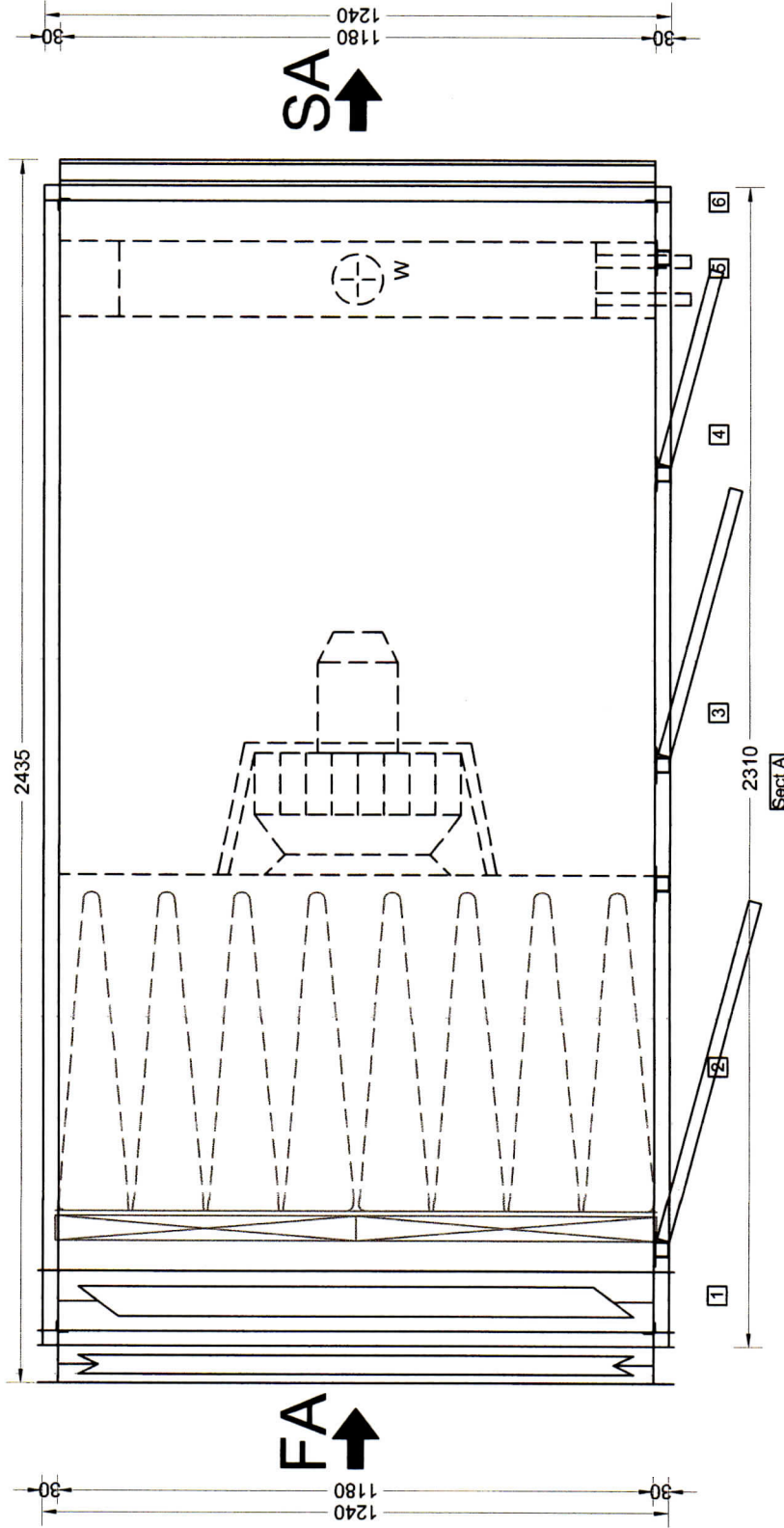

PLAN DECK

AIRDESIGN (UK) LTD UNIT 46, PENSNETT TRADING ESTATE, KINGSWINFORD, WEST MIDLANDS, DY6 7US T: +44 (0) 1364 275760 F: +44 (0) 1364 275810 E: SALES@AIR-DESIGN.COM	Project : Marble Hill	Project ref : 04879-1-0	Date : 12 Oct 2016
	Unit reference : Supply AHU - Option 1	Unit number : 04879	Title :
	Number off : 1	Revision : 0	Not to scale

PROJECT DETAILS			
Project No.	04879	Date:	12 Oct 2016
Unit No.	Q04879-01-0	Project Reference:	Marble Hill

ECO design directive data			
Unit typology	UVU (Uni directional Ventilation Unit)		
Unit typology (operation)	NRVU (Non Residential Ventilation Unit), Airflow >1000m ³ /h		
Nominal flow rate (q _{nom})	1.18 m ³ /s		
Supply		Extract	
Nominal flow rate (q _{nom_SUP})	1.18 m ³ /s	Nominal flow rate(q _{nom_EXT})	Not applicable
Velocity	1.54 m/s	Velocity	Not applicable
Drive type	?	Drive type	Not applicable
Fan selection pressure	305 Pa	Fan selection pressure	Not applicable
Fan selection abs power	0.66 kW	Fan selection abs power	Not applicable
Fan static efficiency	53.55%	Fan static efficiency	Not applicable
Motor efficiency	100.00%	Motor efficiency	Not applicable
Drive efficiency	100.00%	Drive efficiency	Not applicable
Inverter efficiency	100.00%	Inverter efficiency	Not applicable
System power	0.66 kW	System power	Not applicable
System efficiency	54.84%	System efficiency	Not applicable
Internal pressure drop of ventilation components	61 Pa	Internal pressure drop of ventilation components (Δp _{int stat_EHA})	Not applicable
Internal power ventilation components	0.13 kW	Internal power ventilation components	Not applicable
Internal specific fan power of ventilation components	110.83 W/m ³ /s	Internal specific fan power of ventilation components	Not applicable
Internal specific fan power of ventilation components (SFP _{int})	Not applicable		
Heat Recovery System			
Type	Not applicable		
Thermal efficiency (η _{t_nrvu}) EN308	Not applicable		
Filter correction			
Filter correction	Not applicable		
Requirement	Calculated	ERP 2016	ERP 2018
Internal specific fan power of ventilation components (SFP _{int_SUP})	110.83 W/m ³ /s	250.00 W/m ³ /s	230.00 W/m ³ /s
SFPInt conform	2018		
SFPInt message			

MUB/T 042 450EC

Item no. 37203

Document type: **Product card**
 Document date: **2016-11-07**
 Generated by: **Systemair Online Catalogue**

Description

- EC-motors, high level of efficiency
- 100% speed controllable
- Up to 120°C medium temperature, continuous operation
- Multi-functional use, e.g. for kitchen exhaust air
- Pre-assembled isolator is standard
- Low sound level
- Easy to maintain and reliable
- Motor outside the air stream
- Integrated motor protection
- Potentiometer included for ease of commissioning

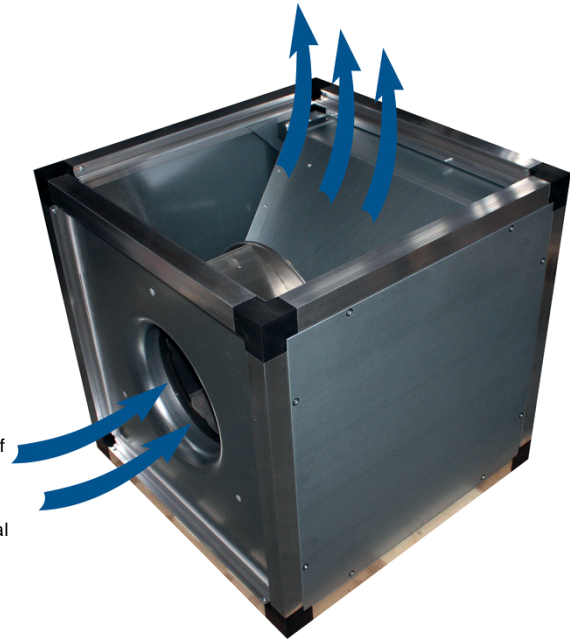

EC technology is intelligent technology; using integral electronic control which eliminates the slip losses in the motor and ensures that the motor always runs at optimal load and guarantees that the proportion of energy utilized effectively is many times higher and the energy usage considerably lower compared with AC motors. EC fans are notable for their economical use of energy and excellent ease of control. They can be varied in speed to match the airflow demand, and operate at high efficiency levels. For the same air volume, they consume distinctly less energy than AC fan drives. Another special feature of EC fans is their energy-saving potential not only at full load, but especially at part-load. When operating at part load, the energy used is much lower than with an asynchronous motor of equivalent output. Reduced energy usage guarantees a drop in operating costs. The power electronics are integrated in the motor housing. All MUB/T-EC models have one potential-free terminal for error message. All motors are suitable to be used for 50/60Hz. The input voltage for single phase units can vary between 200 and 277V. Speed control by a 0-10V signal. The fans are delivered with a pre-wired potentiometer (0-10 V) that allows you to easily find the required working point. All MUB/T-EC fans have impellers with backward curved blades, manufactured from aluminium. The MUB/T-EC fans are suitable for medium temperatures up to 120°C continuously. The casing consists of an aluminium frame with fibreglass reinforced plastic corners and double skin, galvanised steel panels with a 20 mm mineral wool insulation. Panels are removable, allowing flexible ventilation solutions - the air direction can easily be changed. With quick lock access door. The MUB/T-EC bottom panel is shaped as a grease tray and incorporates a pre-mounted 1" drain plug. An isolator switch is mounted on the casing. Several filter modules like f.e. activated carbon- or aluminum filters are available, calculated individually on the working point.

Technical parameters

Nominal data		
Voltage	400	V
Frequency	50/60	Hz
Phase	3	~
Input power (P1)	827	W
Current	1,39	A
Max. airflow	1,74	m³/s
R.p.m.	1442	r.p.m.
Weight	60,1	kg
Temperature data		
Max. temperature of transported air	120	°C
Sound data		
Sound pressure level at 3 m	47	dB(A)
Protection / Classification		
Insulation class	B	
Enclosure class, motor	IP55	IP

Diagrams

Diagrams

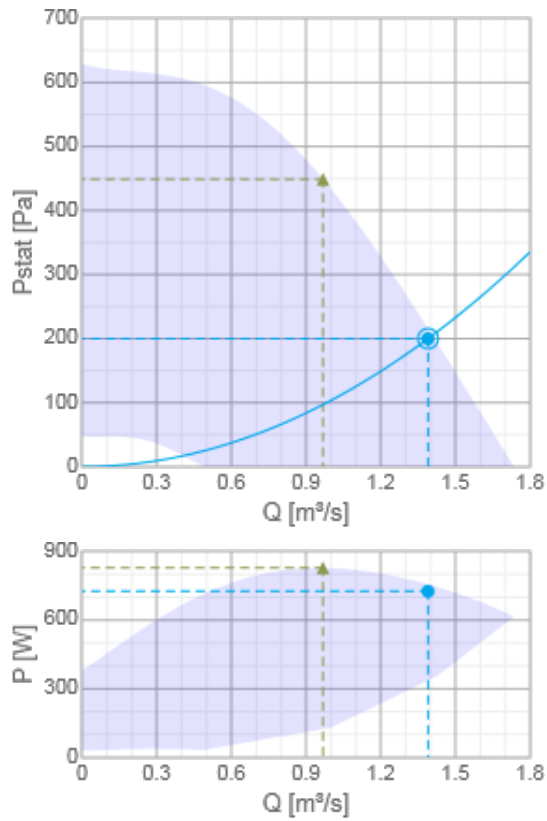

Hydraulic data

	Required point		Working point						
	Q [m³/s]	Ps [Pa]	Q [m³/s]	Ps [Pa]	P [W]	n [r.p.m.]	I [A]	SFP [W/(l/s)]	U [V]
Max efficiency			0,968	449	828	1439	1,39	0,855	400
User	1,39	200	1,39	200	726	1439	1,25	0,522	400

Dimensions

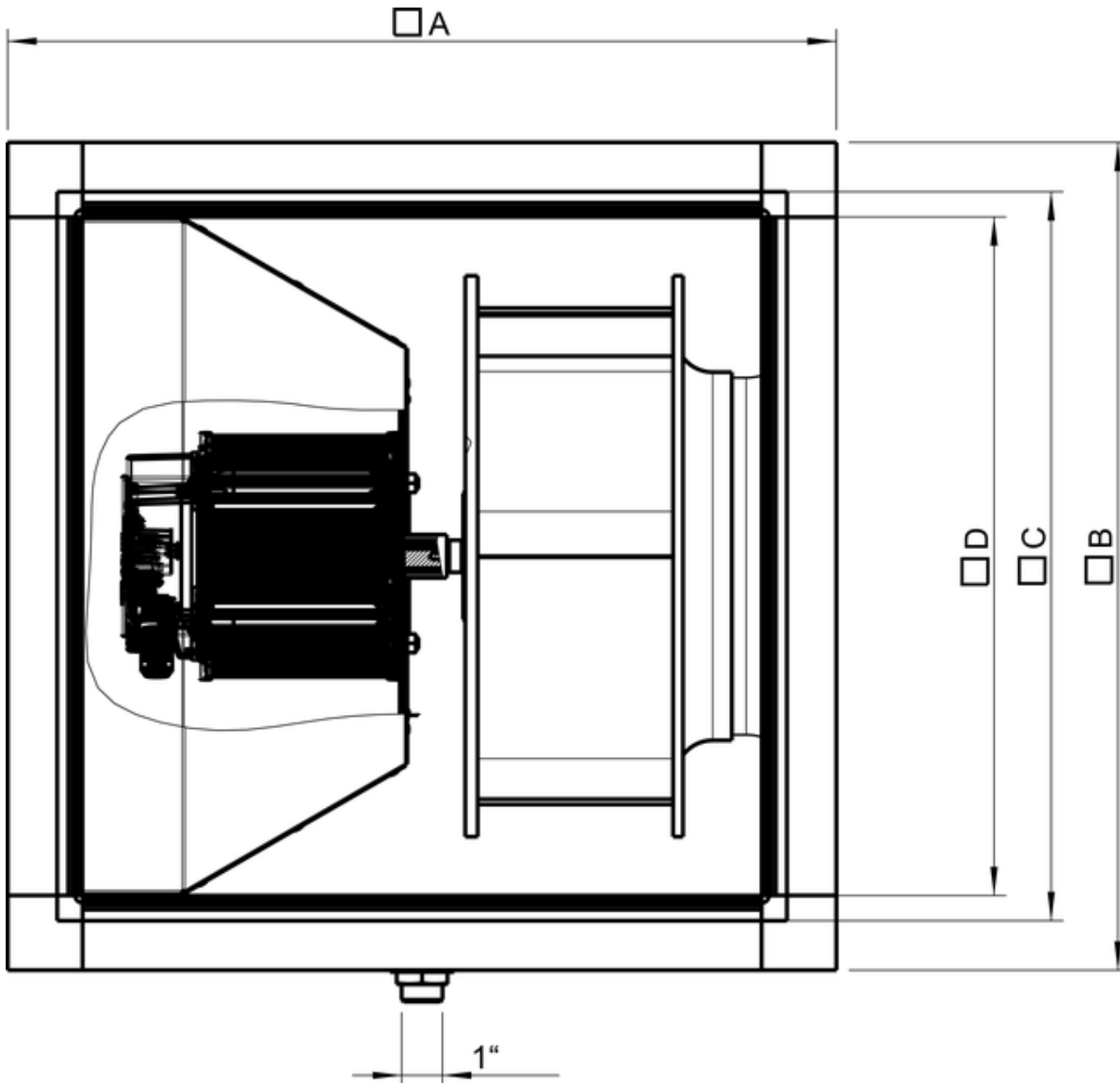

	□A	□B	□C	□D	∅E	∅F
MUB/T 042 450EC	670	670	590	548	454	286

Wiring

 [MUB-T 042 450 EC-Poti_37203_DE-EN.pdf](#) (883,44kB)

Accessories

Electric accessories

- CO2RT-R-D Transmitter (6993)
- Presence detector/IR24-P (6995)
- RT 0-30 Room Thermostat (5151)
- HR1 Room Humidistat IP21 (5150)
- MTP 10, 10K, Speed control (32731)
- EC-Vent Room Unit (3018)
- EC-Vent control board (3115)
- MTP 20, on/off, 3-step (310220)
- MTV-1/010 Controller 0..10V+ (30650)
- CXE/AV Digital regulator (30674)
- EC-Basic-T temperature (24805)
- EC-Basic-U universal 0-10V (24806)
- EC-Basic-H humidity (24807)
- EC-Basic-CO2 and temperature (24808)
- CXE/AVC Modbus (37256)
- S-5EC/FRQ (76738)

Accessories

CCM outlet MUB042 d400 (311682)
 CCM outlet MUB042 d500 (311683)
 UGS 042/500 adapter flex. (4357)
 FGV 042/586-586 flex. conn. (4605)
 SDM Service Door MUB 042 comp. (32572)
 WSD 042 (730x730x70) complete (31481)
 M-SG 042/588x588 (301345)
 CCM inlet MUB042 d400 (311780)
 CCM inlet MUB042 d500 (311781)
 WSG 042 MUB/T complete (36071)
 SD-MUB Vibration pad set (37324)
 CCMI outlet 042 d400 insul KIT (313845)
 CCMI outlet 042 d500 insul KIT (313846)
 TUNE-AHU-DE007-042-588x588-M0 (79881)

Documentation

 [IMO_MUB-EC_151126_DE,EN_003_314464_web.pdf \(2,20MB\)](#)

 [EC-declaration of conformity AxZent-KBT-KBR-MUB-K-MUB-T-DVV_DE-EN.pdf \(103,14kB\)](#)

 [EC-DEC_MUB_151021_DE,GB_001.pdf \(580,98kB\)](#)

Acoustics

Mid-frequency band, Hz

	Hz	Tot	63	125	250	500	1k	2k	4k	8k
LwA Inlet	dB(A)	69	56	58	62	64	63	60	45	48
LwA Outlet	dB(A)	71	58	60	64	66	65	62	57	50
LwA Surrounding	dB(A)	54	41	43	47	49	48	45	40	33

Measuring point: qv = 0,95 m3/s, Ps = 455 Pa