

Revisions:	Drawn / Chkd:	Date:
P1 Revised to LPA preapp comments	MAS	22/11/18
P2 Updated to Council comments. Basement lift added as agreed with client.	MAS	21/12/18
P3 Information Issue	MAS	09/01/19
P4 Planning Issue	MAS	11/01/19



South Elevation (Seymour Lodge)  
1 : 100



West Elevation (Wick House)  
1 : 100

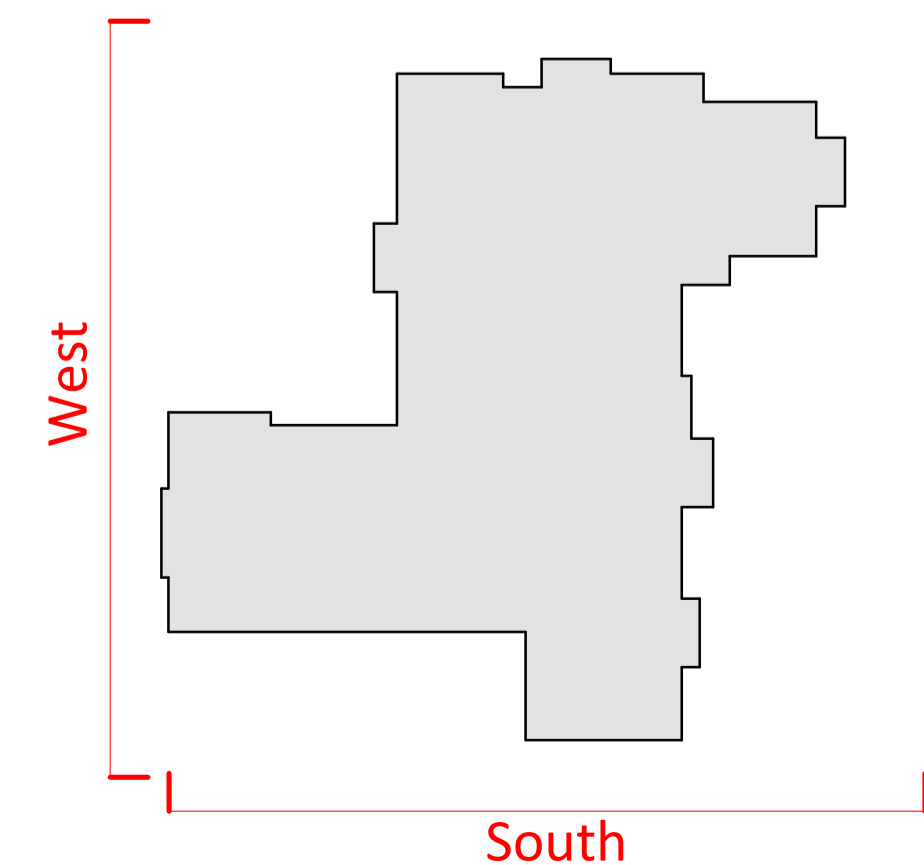
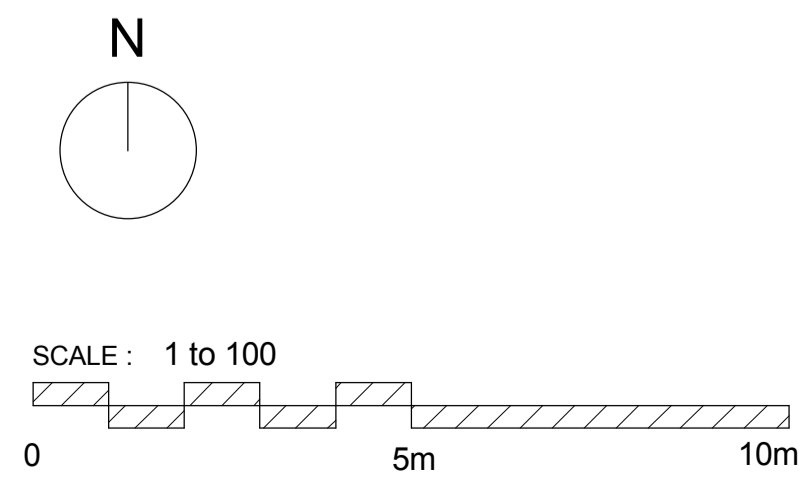

Key Plan  
1 : 500

Preliminary Issue

Client:  
The Sons of Divine Providence Developments Ltd

Project:  
12-14 Station Road & 13, 19-33 Lower Teddington Road

24 Church St. West, Woking, Surrey, GU24 6HT  
01483 494 350  
info@prc-group.com  
www.prc-group.com



Drawing Title:  
Proposed South & West Elevation

Scale @ A1: As indicated  
Checked by: MAS  
Date: 08/13/18

Job No: 10901  
Stage\_Drawing No: PL\_017  
Rev: P4

Issue Status:  
Construction  Preliminary   
Information  Approval   
Tender

Architecture  
Planning  
Master Planning  
Urban Design  
Interiors  
Landscape

Offices  
Woking  
London  
Milton Keynes  
Warsaw