

PLAN SECTION

4 No TO THIS
SW07/SW08/SW11/SW12

FRAME DETAILS - SCALE 1;10

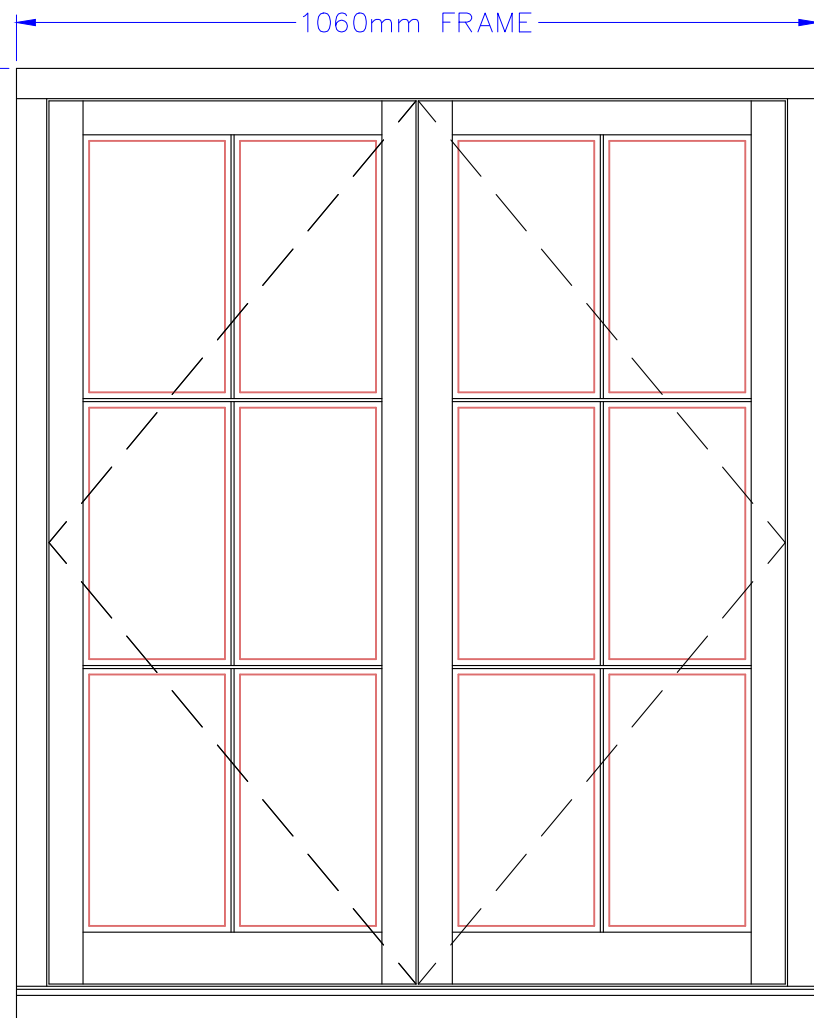

FRONT ELEVATION

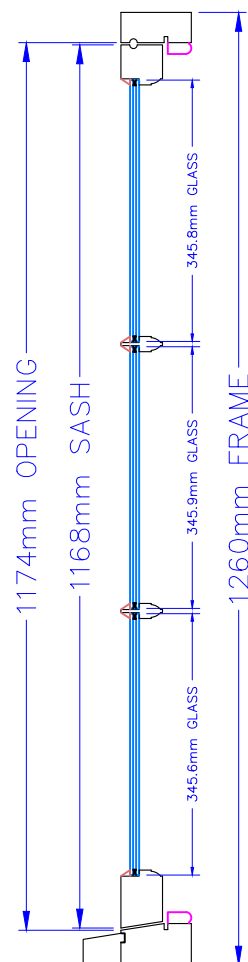

SECTION

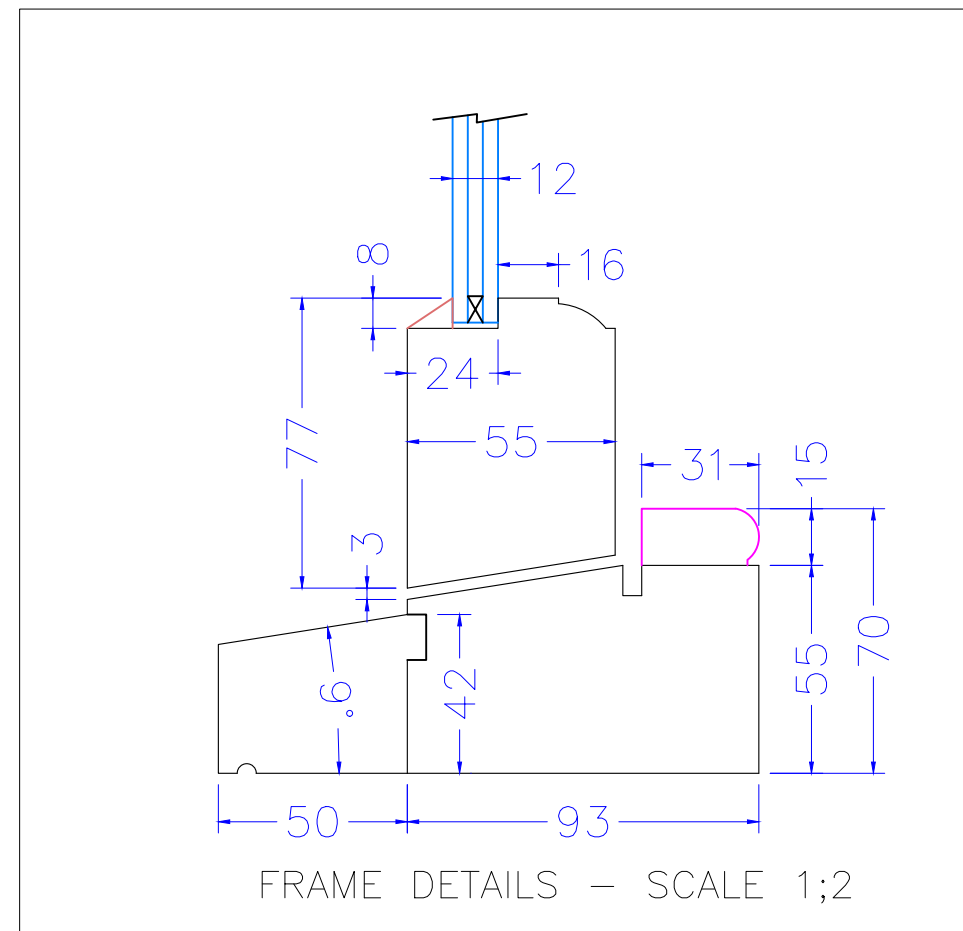

JOB:
DUNCAN O' KELLY

REVISIONS:

Duncan O' Kelly - 07710080632
duncan@duncanokelly-partnership.com

CLIENT:
Duncan O' Kelly - 01243 814 532
Garden House Studio , Eartham , Chichester
West Sussex , PO18 0LS

PROJECT:
Leyland House , Mortlake SW14 7QR
Various Accoya Windows , Brass Butts
Brass Ironmongery , Espag Locking

TITLE:
Butt Hinges-Espag Locks-Brass Ironmongery
3 Coat Finish White,4-4-4 Putty Glazed DGUs
Plan , Section & Elevation

DRAWING No:
Q249 - J028 - A

REVISION: APPROVED FOR DISTRIBUTION BY:

DRAWN BY: DATE: SCALE: SHEET:
DEREK 01/12/20 VARIOUS A3

DRAWING FILE NAME (DWG):

DRAWING FILE LOCATION:
C:\Documents & Settings\FineLine\My Documents\Autocad Drawings\2020\Q249-J028-Plan O' Kelly-Leyden House

COPYRIGHT
THIS DRAWING THE INFORMATION CONTAINED AND THE
DESIGNS EXPRESSED ARE THE SOLE PROPERTY AND
COPYRIGHT OF FINELINE JOINERY LTD. REPRODUCTION IN
ANY FORM BY ANY PERSONS OF THE WHOLE OR ANY PART
OF THIS DRAWING OR THE USE OF THE INFORMATION BY ANY
THIRD PARTY UNLESS EXPRESSLY AUTHORISED IN WRITING
BY FINELINE TRADITIONAL JOINERY LTD. WILL BE AN
INFRINGEMENT OF COPYRIGHT.

fineline
TRADITIONAL JOINERY LTD

**NORTH END YARD
NORTH STREET
PETWORTH
GU28 9NH**

Tel: +44 (0) 1798 422 530
E-mail: enquiries@fineline-joinery.co.uk
Website: www.fineline-joinery.co.uk