



Arboricultural Consultancy
Holmwood Farm Grange Horsham Road North Holmwood Dorking Surrey RH5 4JR
Tel: 01306 743374 Email: info@challiceconsulting.co.uk Web: www.challiceconsulting.co.uk

Tree Survey
Arboricultural Impact Assessment
Arboricultural Method Statement

Relating to:

14 Trafalgar Road, Twickenham TW2 5EJ

Produced for:

Mr. Tim Garbett

Prepared by:

Challice Consulting Ltd.

Mr. David Challice

Dip. Arb. (RFS), F. Arbor. A, MICFor

Chartered Arboriculturist

Date:

4th June 2021

Our Ref:

AR4678

INTRODUCTION	SECTION
Frequently Used Key Terms and Abbreviations	1.0
The Proposal	2.0
Instructions and Purpose	3.0
Scope	4.0
Documents Supplied/Used	5.0
Site Details	6.0

TREE SURVEY	
Survey Method	7.0
Tree Details	8.0

ARBORICULTURAL IMPACT ASSESSMENT	
Introduction to Arboricultural Impact Assessment	9.0
Tree Removal and Retention	10.0
Tree Pruning Works	11.0
Incursions into Root Protection Areas	12.0
Proximity Issues and Shading	13.0
Summary of Arboricultural Impact	14.0

ARBORICULTURAL METHOD STATEMENT	
Introduction to Arboricultural Method Statement	15.0
Pre-Commencement Meeting	16.0
General Site Precautions	17.0
Tree Works	18.0
Tree Protective Fencing	19.0
Ground Protection	20.0
Site Access/Hard Surfaces	21.0
Demolition	22.0
Underground Services	23.0
Foundations	24.0
Hard Landscaping/Material Storage	25.0
Soft Landscaping/Boundary Fencing	26.0
Sequencing/Supervision, Responsibility and Incident Reporting	27.0
Amendments	28.0

APPENDICES

Appendix 1 Tree Survey Schedule with Recommended Tree Works
Appendix 2 Tree Protection Plan in Colour at A1 and Scale 1:100 with Tree Protective Fencing Specification
Appendix 3 Example of Site Inspection Record
Appendix 4 Induction Form for Personnel
Appendix 5 Guidelines for Installing Low Invasive Surfaces

INTRODUCTION

1.0 Frequently Used Key Terms and Abbreviations

Tree Preservation Order	TPO
Arboricultural Method Statement	AMS
British Standard 5837:2012 – Recommendations for Trees in Relation to Design, Demolition and Construction	BS 5837
British Standard 3998:2010 - Recommendations for Tree Work	BS 3998
Root Protection Area/Root Protection Areas	RPA/RPAs
Local Planning Authority	LPA
Cellular Confinement System	CCS

2.0 The Proposal

- 2.1 It is proposed to construct a parking area in the front garden and install gates and railings.

3.0 Instructions and Purpose

- 3.1 This report has been commissioned by Mr. Tim Garbett to;
- Survey the trees in accordance with British Standard (BS 5837) 5837:2012 - Trees in Relation to Design, Demolition and Construction- Recommendations.
 - Make suggestions to decrease the arboricultural impact of the proposed scheme on the retained trees during the design process.
 - Detail the arboricultural impact of the proposed project.
 - Prepare a tree work schedule to British Standard (BS 3998) 3998:2010 - Recommendations for Tree Work.
 - Develop a tree protection strategy for the duration of the development including any demolition works.
- 3.2 Provision of the above information is designed to address the requirements of the LPA in terms of the arboricultural information necessary to register and determine the planning application.

4.0 Scope

- 4.1 In surveying the trees to the requirements of BS 5837, trees on and immediately adjacent to the site with a stem diameter over 75mm have been included. Large shrubs and hedges have been included where these are considered to be of significant amenity value. These are particularly important where they provide boundary screening. For clarity and ease of data interpretation, large shrubs have been classified as trees.

- 4.2 A full hazard assessment of the trees (including the assessment of decay or defects and their impact), has not been undertaken as this is considered beyond the scope of this report. Any obvious hazards and defects have been identified in the Tree Survey Schedule and appropriate works recommended for immediate action.
- 4.3 It is the Client or their representative's responsibility to review the contents of this report to ensure it meets their requirements before it is sent to the LPA.

5.0 Documents Supplied/Used

Document	Obtained From	Format/Ref.
Existing and proposed layout plans	Tholos Architects	Dwg.

6.0 Site Details

- 6.1 The site is comprised of a residential dwelling with associated gardens and hard surfaces.
- 6.2 There are no significant inclines in any direction that would affect the recommendations in this report.
- 6.3 The site is within the administrative jurisdiction of the London Borough of Richmond -upon-Thames.
- 6.4 I have not been instructed to ascertain the protection status of any of the trees on or near the site.

TREE SURVEY

7.0 Survey Method

- 7.1 The site and trees were inspected on Tuesday, 11 May 2021.
- 7.2 The trees were inspected from ground level and no climbing inspections were undertaken.

Challice Consulting Ltd.

Holmwood Farm Grange Horsham Road North Holmwood Dorking Surrey RH5 4JR
Tel: 01306 743374 Email: info@challiceconsulting.co.uk Web: www.challiceconsulting.co.uk

7.3 Stem diameters were measured using a diameter tape at 1.5m from ground level unless stated in the Tree Survey Schedule at **Appendix 1**. The locations of the surveyed trees have originated from the drawings supplied by the Client unless otherwise stated in the Tree Survey Schedule.

8.0 Tree Details

8.1 The total number of records is as follows:

Individual Trees (T): 7

Tree Groups (G): 2

8.2 The tree details and proposed works are presented in the Tree Survey Schedule with Recommended Tree Works at **Appendix 1** and tree positions are shown on the Tree Protection Plan at **Appendix 2**.

8.3 The quality and value of the tree stock has been broken down by BS 5837 quality grade. The grading system can be summarised as follows:

A Grade – trees of high quality and value with a life expectancy of more than 40 years

B Grade – trees of moderate quality and value, with a life expectancy of more than 20 years

C Grade – trees of low quality and value, with a life expectancy of more than 10 years

U Grade – trees usually for removal (unless otherwise stated), with a life expectancy of less than 10 years

Quality and Value of Existing Tree Stock

	A Grade	B Grade	C Grade	U Grade
No. of Tree Records by Grade	0	4	5	0

8.4 The RPAs of the trees are included in the Tree Survey Schedule with reference to Table 1 of BS 5837. The RPA is the area, measured in m², which is calculated in accordance with the BS 5837 using the stem diameter of the trees. This should provide retained trees with sufficient rooting environment to survive the proposed development. Section 4.6.3

of BS 5837 provides for the shape of the RPA to be modified from the starting point of a circle to account for site features where rooting may be restricted, as long as the total area remains the same.

Diagrammatic Representation of a Restricted Root Protection Area

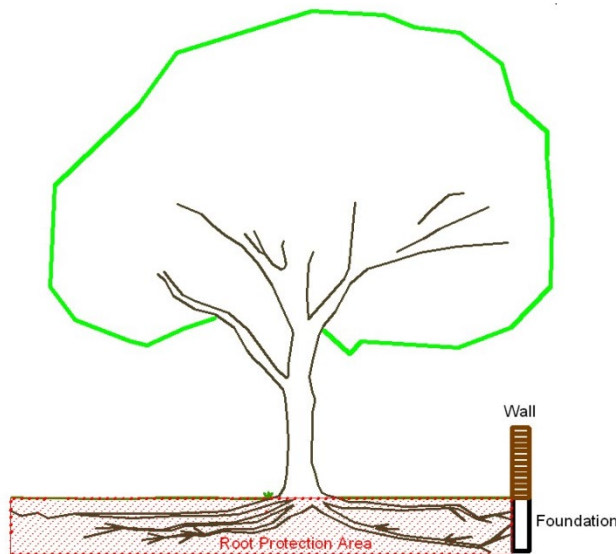

Modified RPAs

Tree No.	Impediments to Normal Rooting
Common Hazel T7	Existing hard surfacing outside the site

ARBORICULTURAL IMPACT ASSESSMENT

9.0 Introduction to Arboricultural Impact Assessment

9.1 This section comprises an assessment of the impact the proposed works detailed in Section 2 above have on trees. It considers the arboricultural impact and how this may be mitigated.

10.0 Tree Removal and Retention

10.1 The proposed scheme provides for the retention and protection of all the trees surveyed with the exception of part of mature shrub group G3 and Common Holly T4.

11.0 Tree Pruning Works

- 11.1 Minor tree pruning is recommended for good arboricultural practice and to ensure reasonable clearance from the proposed construction. The pruning described in the Tree Survey Schedule with Recommended Tree Works at **Appendix 1** will not adversely affect the trees or their contribution to local amenity.

12.0 Incursions into Root Protection Areas

- 12.1 The table below summarises the significant incursions into the RPAs of noteworthy, retained trees. The 'Action' column details how the incursion has been mitigated and why it is considered acceptable. Incursions may be fully invasive (where specialist methods are not used and some root loss is considered acceptable) or low invasive (where specialist methods are used to minimise damage to or loss of roots). Full details of how the works will be carried out without causing damage to the trees are given in the AMS.

Summary of Incursions into RPAs

Tree No.	Type of Incursion	Impact	Action
T2, G6, T7, T8 and T9	Low invasive	Low	A permeable low invasive surface will be installed under direct arboricultural supervision on top of the existing soil level under direct arboricultural supervision to limit root disturbance to an acceptable level (see Appendix 5)

- 12.2 No new underground services are to be installed within the RPAs of the retained trees.

13.0 Proximity Issues and Shading

- 13.1 The shade patterns for the surveyed trees have not been plotted as this is not a constraint to this type of development.

14.0 Summary of Arboricultural Impact

- 14.1 In summary, the arboricultural impact of the proposed scheme is relatively minor as during the landscaping phase of the development there is an opportunity to plant trees in the space outside the development footprint to mitigate for those recommended for removal. These areas have been safeguarded with tree protective fencing where possible to protect the planting medium in these areas.
- 14.2 The retained trees can be afforded an appropriate degree of protection in accordance with the BS 5837 as detailed in the AMS.
- 14.3 I have assessed the impact of the proposed development and it is considered to be in line with the recommendations set out in British Standard 5837.

ARBORICULTURAL METHOD STATEMENT

15.0 Introduction to Arboricultural Method Statement

- 15.1 To safeguard the retained trees (both above and below ground parts) during the development works and preserve the soil structure of areas which could be allocated for new planting, it will be necessary to implement tree protection measures as outlined below.
- 15.2 The basic principle is that the area inside the tree protective fencing and where ground protection has been used is to be protected for the duration of the works.
- 15.3 A copy of this AMS shall be maintained on site at all times and made available to all site personnel.
- 15.4 All site personnel shall be made aware of the key impact of this AMS and be given an arboricultural induction by the Site Manager. An Induction Form is attached at **Appendix 4**. A copy of the Induction Form will be signed by all site personnel to confirm that they have understood the issues involved.

- 15.5 As of 2005, Local Planning Authorities have powers to serve **Temporary Stop Notices** if agreed tree protection measures are not carried out. Adhering to this AMS will ensure that such costly and time consuming action is avoided.

16.0 Pre-Commencement Meeting

- 16.1 A pre-commencement site meeting, involving representatives from the Development Company, the Arboricultural Consultant and the LPA Tree Officer will be held to ensure that all aspects of the tree protection process are understood and agreed. A record of the meeting will be communicated to all parties by the Arboricultural Consultant within five days of the meeting.
- 16.2 Attendance at a pre-commencement site meeting and for any site supervision (see Section 27.0) is chargeable at the standard hourly rate as stated in the terms and conditions attached to the quotation for this report.

17.0 General Site Precautions

- 17.1 The following points will be observed at all times:
- No fires will be lit on site during the construction or demolition phases.
 - No access will be permitted inside the tree protective fencing.
 - No materials, equipment or debris will be stored within the tree protective fencing.
 - Notice boards, telephone cables or other services will not be attached to any parts of the retained trees.
 - Materials which will contaminate the soil (e.g. diesel oil and vehicle washings) will not be permitted to migrate into the RPAs of the retained trees.
 - A dedicated mixing and cleaning area will be set up to prevent concrete, cement and cleaning residue leaching into the RPAs of the retained trees (see Tree Protection Plan for specification).
 - Site cranes are to be automatically programmed to avoid loads striking the crowns, stems and branches of the retained trees.
 - Scaffolding will be erected outside the RPAs of the retained trees or on top of the ground protection if specified.

Challice Consulting Ltd.

Holmwood Farm Grange Horsham Road North Holmwood Dorking Surrey RH5 4JR
Tel: 01306 743374 Email: info@challiceconsulting.co.uk Web: www.challiceconsulting.co.uk

- Site and lorry mounted cranes are to be automatically programmed (or a banksman will be present) to avoid loads striking the crowns, stems and branches of the retained trees.
- All vehicle movements associated with the site (including skips) will be supervised by the on-site Arboricultural Liaison to ensure that the retained trees are not damaged during loading or unloading.
- All cement/toxic materials are to be stored inside the site and not in the RPAs of any retained trees.

18.0 Tree Works

- 18.1 All tree works will be carried out in accordance with BS 3998:2010 'Recommendations for Tree Work' (as amended) and to current arboricultural best practice. Tree works will be carried out by a suitably qualified and experienced Arboricultural Contractor holding the necessary insurance cover. This contractor should carry out the relevant site specific risk assessments and record such information prior to commencement of tasks and work in accordance with current health and safety standards, practices and legislation. A list of such contractors is available from the Arboricultural Association at www.trees.org.uk.
- 18.2 The subject trees may be protected by virtue of being within a Conservation Area or covered by a TPO. Submission of this AMS in connection with a planning application should be construed as a formal application to carry out those works specified in the Tree Survey Schedule with Recommended Tree Works at **Appendix 1**. It is recommended that this matter be clarified by the Client in writing with the LPA prior to any works commencing.
- 18.3 In addition, prior to the commencement of any tree works, an ecological assessment of specific trees may be required to ascertain whether protected species (e.g. nesting birds, bats, badgers and certain invertebrates) may be affected.
- 18.4 Tree ownership should be clarified in writing by the Client before any trees are removed or pruned.

- 18.5 If additional pruning of trees is required to facilitate the proposed works or access for machinery/plant, the Arboricultural Consultant will be contacted to advise on appropriate works and liaise with the LPA as necessary.

19.0 Tree Protective Fencing

- 19.1 Tree protective fencing is used to ensure that the RPAs of the retained trees are safeguarded. These measures may also be employed to protect areas of ground for new landscaping.
- 19.2 The positioning and specification of the fencing is shown in **Appendix 2**. In this case, the default specification of BS 5837 consisting of **fixed Heras** fencing would be effective.
- 19.3 The protective fencing will remain in position for the duration of the development, including the removal of any existing structures. Clear signs will be attached to the fencing once erected – suggested wording will be **‘Construction Exclusion Zone No Access’**.

20.0 Ground Protection

- 20.1 In this instance, there is no requirement for ground protection as the RPAs of the retained trees can be afforded an adequate degree of protection using tree protective fencing and the existing hard surfacing.

21.0 Site Access/Hard Surfaces

- 21.1 The construction of the driveway and parking bays within the RPAs of the retained trees will occur at the initial stage of development to ensure the RPAs of the retained trees are protected (position shown at **Appendix 2**). A CCS is to be used, the depth of which will be determined following consultation with a Structural Engineer or the supplier. Guidelines for installing low invasive hard surfaces within the RPAs of the retained trees are attached at **Appendix 5**. This will have an impact on final levels as the principle is to build up levels rather than carry out any excavation. The final surface should be protected during the development to prevent damage to the structure of the roots below and the need for re-laying. The tree protective fencing can be relocated under arboricultural supervision to

enable this process. The final surface should be protected during the development with heavy duty (40mm thick) track mats to prevent damage and the need for re-laying.

22.0 Demolition

22.1 There is no requirement for demolition within the RPAs of the retained trees.

23.0 Underground Services

23.1 The electric supply for the gate will be located in a 200mm wide trench that is to be hand dug outside the RPAs of the retained trees in the location show on the Tree Protection Plan at **Appendix 2**.

23.2 The locations, specifications and installation methods of the new services will be available for review at the pre-commencement site meeting before any works start on site.

24.0 Foundations

24.1 There is no requirement for any foundations within the RPAs of the surveyed trees.

25.0 Hard Landscaping/Material Storage

25.1 Hard landscaping is taken to include the construction of associated hard landscaping features such as retaining walls, patios, and cycle stores. There is no requirement for additional hard landscaping within the RPAs of the retained trees.

25.2 The storage of all materials required to complete the construction process will be located outside the RPAs of the retained trees and the line of the tree protective fencing.

25.3 Subject to all of the above tree protection measures being implemented, construction works may proceed without risk of damage to the retained trees.

26.0 Soft Landscaping/Boundary Fencing

26.1 Soft landscaping will be undertaken when heavy machinery has been removed from site and tree protective fencing taken down. The following points will be observed:

- Care will be taken not to compact the soil within the RPAs of the retained trees or where new tree planting is to be carried out.
- No changes in ground levels will occur within the RPAs of the retained trees.
- Unwanted vegetation will be removed manually or using contact herbicides that will not damage existing tree roots.
- No irrigation or drainage pipes will be installed within the RPAs of the retained trees.
- If soil has been compacted in areas where planting is proposed, measures to improve soil structure (e.g. decompaction) may be necessary to facilitate successful plant establishment.
- Where fence and gate post holes are to be installed within the RPAs of the retained trees, they shall be lined with heavy duty polythene to prevent the harmful cement leaching into the soil and damaging the roots of the retained trees.

27.0 Sequencing/Supervision, Responsibility and Incident Reporting

27.1 Effective tree protection relies on following a logical sequence of events and arboricultural inspection/supervision.

27.2 Works which have the potential to affect trees will be supervised by a suitably qualified and experienced Arboricultural Consultant. Regular inspection visits will also be undertaken to ensure that tree protection measures are being adhered to. The final details of supervision and the frequency of inspection visits will be agreed with the Tree Officer at the pre-commencement meeting. The Arboricultural Consultant will make a record of visits, which will be attached to the site copy of the AMS for

- inspection and communicated in writing to the LPA within five days of the site visit. An example of the Site Inspection Record is found in **Appendix 3**.
- 27.3 Daily inspection of the physical tree protection measures will be carried out by the on-site Arboricultural Liaison, who does not have to be a trained Arborist, but will be responsible for the implementation of the approved tree protection. Any deviation from the approved methodologies will need to be agreed by the Arboricultural Consultant who may need to visit site to authorise the revised tree protection measures. It is the responsibility of the Client or the Arboricultural Liaison to instruct the Arboricultural Consultant to attend site for the key events requiring supervision or monitoring. Any required modification to the tree protection measures or building techniques within the RPAs of the retained trees will be communicated in writing to both the appointed Arboricultural Consultant and the Tree Officer before the changes occur.
- 27.4 Any damage to stems, branches or any size roots of the retained trees will be reported immediately by email and telephone by the Arboricultural Liaison to the Arboricultural Consultant. The Arboricultural Liaison will take photographs of the damage and send these to the Arboricultural Consultant who will visit site to assess the scale of the damage and report to the LPA Tree Officer. Mitigation for the damage will be agreed with the LPA Tree Officer.

Sequencing and Supervision

Stage	Action/Task	Personnel Responsible
1.	Issue arboricultural report to site manager	Client/Developer
2.	Give Arboricultural Consultant (AC) at least a week's notice of pre-commencement meeting	Client/Developer
3.	Arboricultural induction and appointment of the Arboricultural Liaison	Site Manager
4.	Carry out tree works (the Client is to establish tree ownership and protection status in writing before any tree works are carried out)	Site Manager
5.	Install all tree protective measures	AC to inspect
6.	Pre-commencement meeting	Site Manager, Tree Officer and AC
7.	Install underground service	AC to supervise
8.	Install low invasive hard surfacing	AC to supervise
9.	Remove all tree protective measures	Site Manager
10.	Carry out soft landscaping and erect boundary fencing	Site Manager to brief landscaping company on site and supervise

28.0 Amendments

28.1 Issues sometimes arise on development sites which require amendments to the previously agreed tree protection details. Any amendments to this AMS will be discussed with the Arboricultural Consultant and approved in writing by the LPA prior to being implemented. Copies of paperwork relating to any amendments shall be attached to the site copy of the AMS to provide a definitive record of what has been agreed.

Appendix 1

Tree Survey Schedule with Recommended Tree Works



Site: 14 Trafalgar Road, Twickenham TW2 5EJ
Date Surveyed: 11/05/2021

Surveyor: Mr. David Challice
Job Number: AR 4678

Tree No.	English Name	Height	Radial Crown Spread	Ground Clearance	Life Stage	Stem Diameter	Protection Radius	Growth Vitality	Structural Condition	Landscape Contribution	BS Cat	Useful Life	Observations	Reason/Works/Priority
T1	Magnolia	2m	1m	0m 1m N	Semi Mature	4 stems at 40mm est	1.0m	Good	Good	Low	C (2)	40+	Tree with insignificant defects.	No works proposed.
T2	Silver Birch	17m	6m	4m 3m SE	Mature	480mm est	5.8m	Fair	Fair	Moderate	C (2)	10+	Ivy smothering stem prevented inspection and stem measurement.	Safety: Remove Ivy up to 1m from ground level and re-inspect. 3 months
G3	Mature Shrubs	3m	1.5m	0m 0m N	Mature	100mm ave	1.2m	Fair	Fair	Low	C (2)	10+	Replaceable specimens.	Development: Remove and replace part of group. Before works commence.
T4	Common Holly	13m	4m	6m 7m N	Mature	350mm est	4.2m	Good	Good	Moderate	B (2)	20+	Ivy smothering stem prevented inspection and stem measurement.	Development: Remove and replace. Before works commence.
T5	Bay	8m	3m	0m 0m N	Early Mature	3 stems at 100mm est	2.1m	Fair	Fair	Low	C (2)	20+	Tree with insignificant defects.	No works proposed.
G6	False Acacia	16m	N4m E6m S6m W6m	9m 9m S	Early Mature	3 stems at 400mm est	4.8m	Fair	Fair	Moderate	B (2)	20+	Trees located off site; significant deadwood over 25mm in diameter.	No works proposed.
T7	Common Hazel	9m	4m	0m 0m N	Early Mature	7 stems at 100mm est	3.2m	Good	Good	Low	C (2)	40+	Tree with insignificant defects.	Development: Cut back to the line of the tree protective fencing. Before works commence.
T8	False Acacia	16m	N4m E6m S6m W6m	9m 9m S	Mature	600mm est	7.2m	Fair	Fair	Moderate	B (2)	20+	Tree located off site; significant deadwood over 25mm in diameter.	No works proposed.
T9	Common Yew	15m	N3m E4m S4m W4m	0m 0m N	Early Mature	400mm est	4.8m	Good	Good	Moderate	B (2)	40+	Regularly trimmed as large a bush.	Development: Cut back to the line of the tree protective fencing. Before works commence.

Key for the Tree Survey Schedule with Recommended Tree Works

- **Tree No.** refers to the tree reference number and the prefix of **T** - Single tree, **G** - Tree group, **H** - Hedge or **W** - Woodland.
- **English Name** refers to the tree's common name.
- **Height** describes the approximate height of the tree measured in meters from ground level.
- **Radial Crown Spread** refers to the crown radius in meters from the stem centre and can be labelled as the four compass points of N, E, S, W.
- **Ground Clearance** the first measurement refers to the lowest point of the crown height in meters above ground level, the second measurement is the height of the first significant branch and the cardinal point to which it is growing.
- **Stem Diameter** is the diameter of the stem measured in millimeters at 1.5m from ground level unless otherwise stated. The stem diameter may be estimated (est) where access is restricted or an average (ave) taken for groups or multi-stemmed trees with more than five stems. The number of stems is also indicated.
- **Protection Radius** is a radial distance measured in meters from the trunk centre.
- **Growth Vitality** - **Good**, **Fair** (below normal), **Poor** (sparse/weak) or **Dead** (dead or dying tree).
- **Structural Condition** - **Good** (no or only minor defects), **Fair** (remedial defects), **Poor** (major defects present) or **Hazardous** (defects require immediate remedial tree works).
- **Landscape Contribution** - **High** (prominent landscape feature), **Moderate** (visible in landscape) or **Low** (secluded/among other trees or obscured by structures).
- **BS Cat** refers to British Standard 5837:2012 Table 1 and refers to tree/group quality and value. **A** - High, **B** - Moderate, **C** - Low or **U** - Remove if within site ownership or control. The sub-category is in the line below the BS Cat in parentheses and refers to the retention criteria values where 1 is Arboricultural, 2 is Landscape and 3 is Cultural including Conservational, Historic and/or Commemorative.
- **Useful Life** is the tree's estimated remaining contribution in years.
- **Observations** provide additional information where it is necessary.
- **Reason/Works/Priority** details the reason why the tree works have been specified and the time scale (from the survey date) that the works should be completed.

Appendix 2

Examples of above-ground stabilizing systems for protective barriers

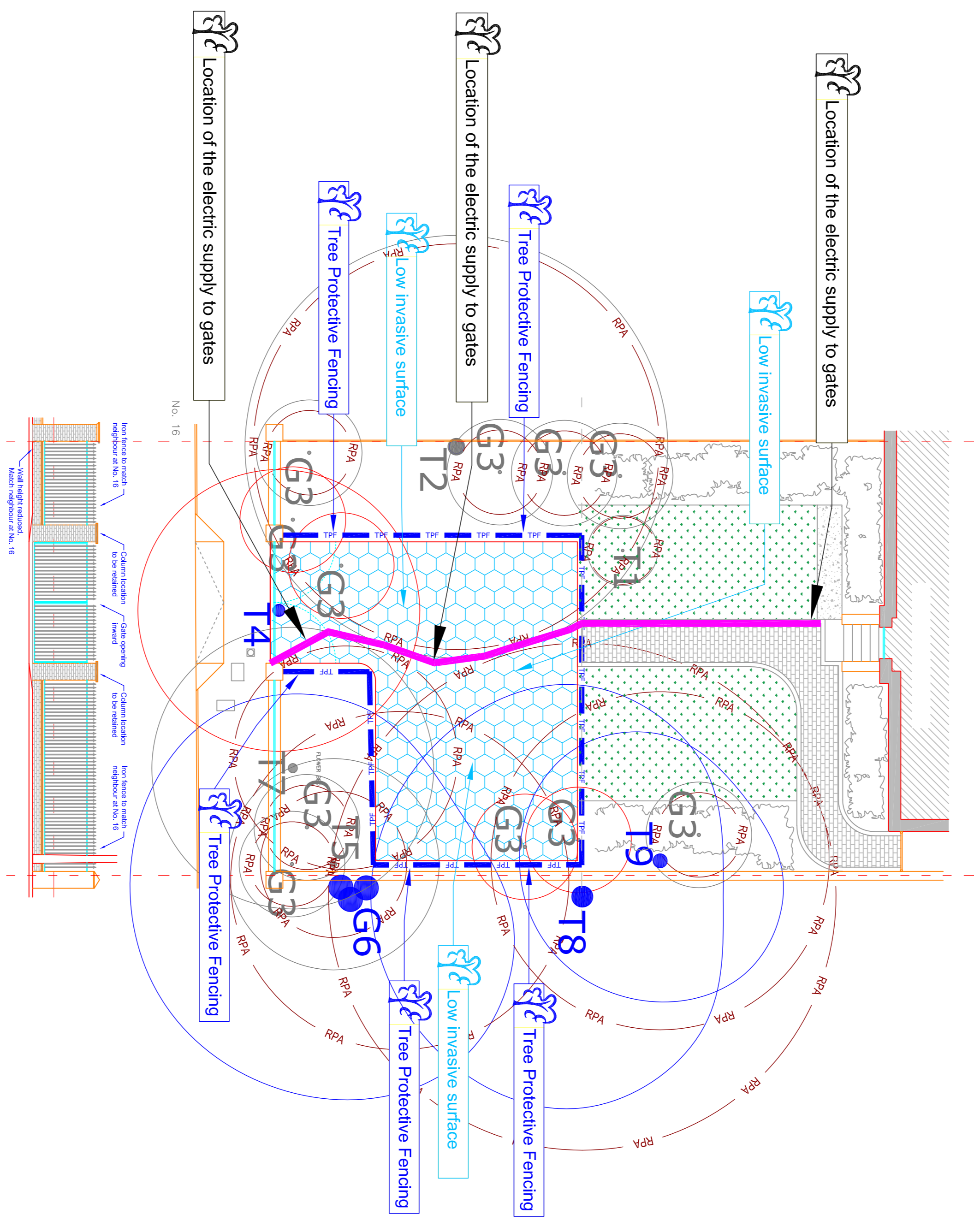
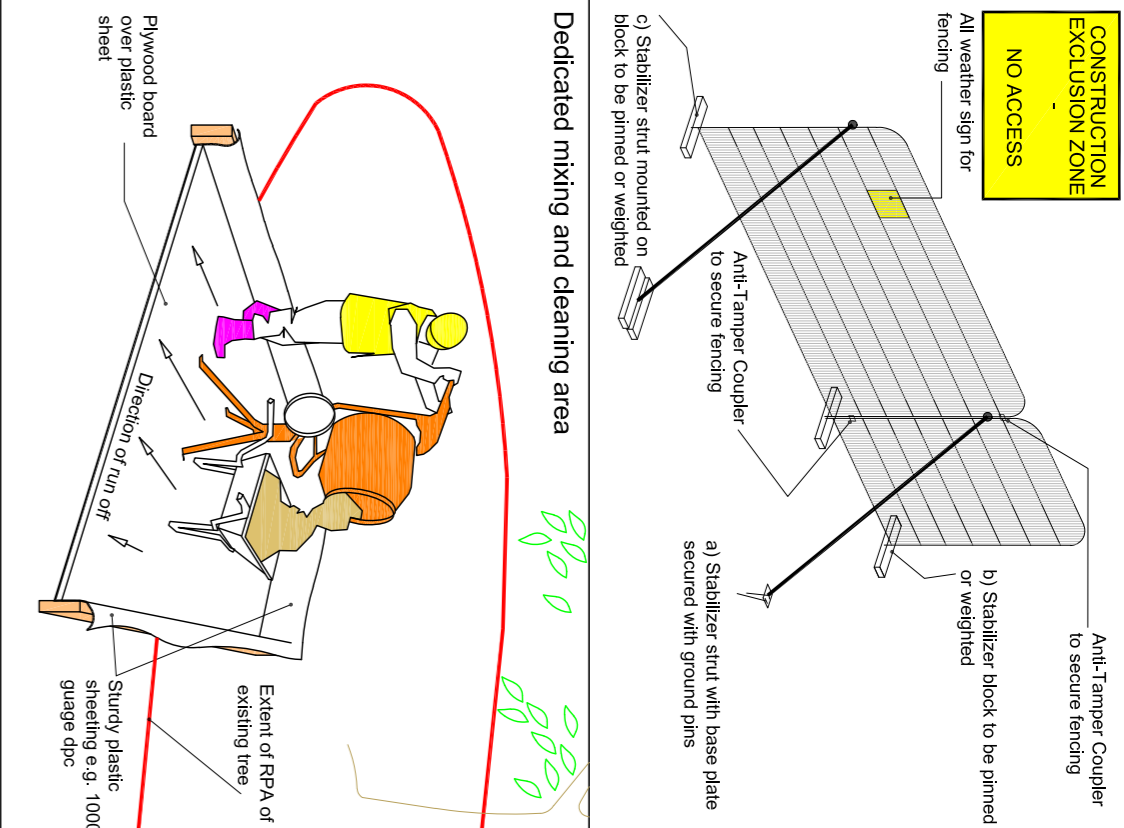

KEY:

- BS mowing area (as shown uniform but may be modified to account for site features)
- BS mowing area that has been modified to account for site features
- A Grade
- B Grade
- C Grade
- U Grade
- Tree to be removed
- Position of fixed barrier fencing
- Low Invasive surface

Challice Consulting Ltd. annotation

NOTES:

Tree protection barrier to be erected and installed before machinery or materials are brought onto site, before any demolition or development of land and before soil stripping.

Tree protection measures should be implemented following any necessary pre-development tree work.

Barriers must not be removed or altered except with prior recommendation by project arboriculturist and where necessary, approval from the Local Planning Authority.

Setting out to be confirmed by project arboriculturist prior to commencement of other operations.

Plan to be printed in colour and to scale

DATE: 14/06/2021

PROJECT: Tree Protection Plan

14 Trafalgar Road,
Twickenham TW2 5EU

Challice Consulting Ltd.

Holmwood Farm Garage
Horsesham Road
North Holmwood
Dorking
Surrey
RH45 4JR
Tel: 01306 743374
Email: info@challiceconsulting.co.uk
Web: www.challiceconsulting.co.uk

THIS PLAN TO BE USED FOR SETTING OUT OF TREE PROTECTION MEASURES ONLY; DO NOT SCALE FROM THIS PLAN UNLESS IT IS PRINTED AT A1. DO NOT USE UNLESS PRINTED IN COLOUR

Appendix 3

Site: Sample
Inspected By: D. Challice
Client: The Builder
Site Agent: No staff present

Date of Inspection:
Time of Inspection:

Tree Protective Fencing

Tree protection in correct location

Comments/Action

No action at this time



Tree protection T23

Agreed Construction Exclusion Zone

No debris within construction exclusion zone

Comments/Action

No action at this time



Tree protection T14

Amendments to Documentation Required

No amendments required

Comments/Action

Remedial Works

Install protection as per Arboricultural Method Statement

General Comments

No ground protection in place for T11,12,14,17 & 22
Sweet Gum T1 not removed

Appendix 4

Induction Form for all Site Personnel:

Site Name:.....

- I have had explained to me by the Site Manager the key implications of the Arboricultural Method Statement relating to the development at the above site.

- I am aware that the tree protective fencing must remain in its original position and must not be moved without the approval of the appointed Arboricultural Consultant.

- I understand that certain operations must be supervised by the appointed Arboricultural Consultant and that these operations must not start until the consultant is present and has given approval.

- I confirm that I will bring any concerns about potential damage to trees to the attention of the Site Manager.

- I am aware that I must not cause damage to any of the retained trees on or adjacent to the site. Damage may be caused by direct means (i.e. physical damage caused to roots or the trunk/branches of the tree) or by indirect means (e.g. by fire or toxic materials entering the rooting environment of the tree).

Print Name:.....

Sign Name:.....

Date:.....

Appendix 5

Guidelines for Installing Low Invasive Surfaces



Chalice Consulting Ltd.

Holmwood Farm Grange Horsham Road North Holmwood Dorking Surrey RH5 4JR
Tel: 01306 743374 Email: info@chaliceconsulting.co.uk Web: www.chaliceconsulting.co.uk

Key Terms and Abbreviations:

Root Protection Area/Root Protection Areas	RPA/RPAs
Cellular Confinement System	CCS
British Standard (BS) 5837	BS
Arboricultural Method Statement	AMS

- 1.0 Avoiding damage to tree roots, oxygen depletion and compaction of subsoil are important considerations when installing hard surfacing close to trees. An acceptable solution with minimal disturbance can be achieved with the use of a Geotextile membrane and the introduction of a CCS. This can be laid directly onto the existing soil level within the RPAs of retained trees. This low invasive CCS system prevents rutting and compaction of the subsoil.

Illustration of Stress Distribution

(Images used with the kind permission of Geosynthetics Ltd, 01455 617139, www.geosyn.co.uk)

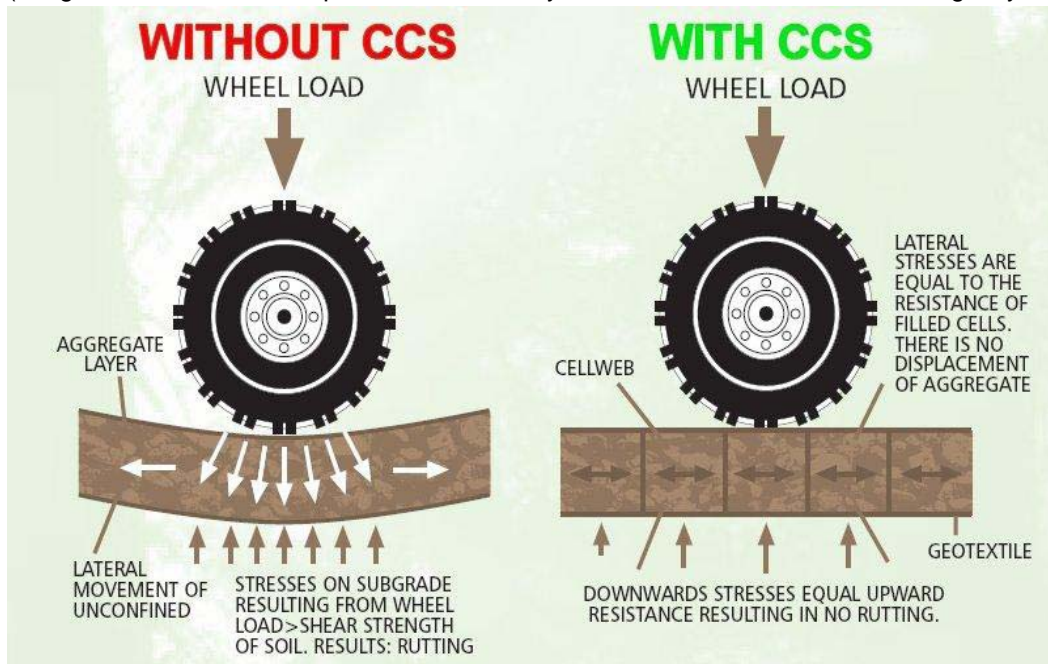

- 2.0 Retained trees must be protected first by the erection of fencing (see diagram below), then by the construction of surfaces in accordance with Sections 9 and 11 of the BS. **The tree protective fencing and surfaces within the RPAs of retained trees must be installed as per the sequencing recommended within the AMS. Hard surfaces constructed in this way can be used for construction access, storage and on-site parking and may need to be installed prior to demolition or construction.**

Challice Consulting Ltd.

Holmwood Farm Grange Horsham Road North Holmwood Dorking Surrey RH5 4JR
Tel: 01306 743374 Email: info@challiceconsulting.co.uk Web: www.challiceconsulting.co.uk

Tree Protective Fencing Detail (alternative materials can be used, though all fencing is to be 'fit for purpose')

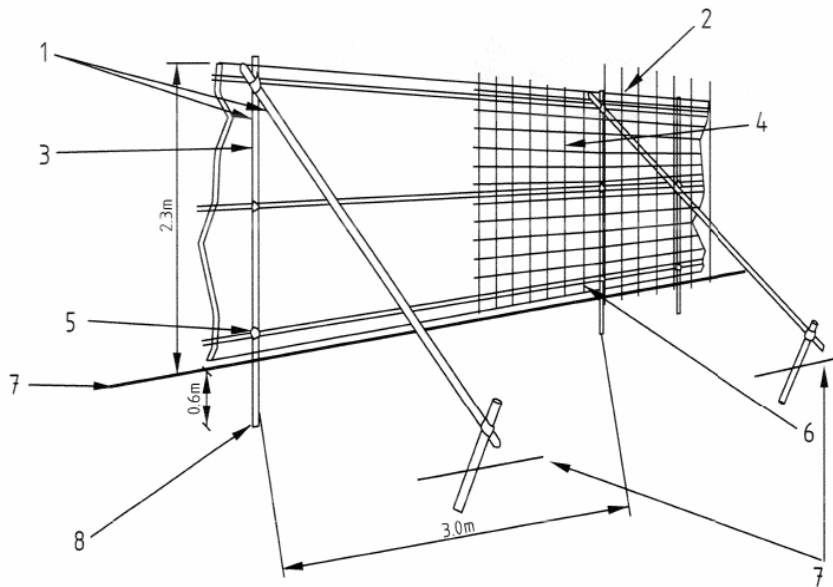

- | | |
|--|--|
| 1 Standard scaffold poles | 5 Standard clamps |
| 2 Uprights to be driven into the ground | 6 Wire twisted and secured on inside face of fencing to avoid easy dismantling |
| 3 Panels secured to uprights with wire ties and where necessary standard scaffold clamps | 7 Ground level |
| 4 Weldmesh wired to the uprights and horizontals | 8 Approx. 0.6 m driven into the ground |

- 3.0 If ground levels are to be raised by more than 100mm within RPAs, this should be achieved by the use of a granular material which does not inhibit vertical gaseous diffusion. For example; no-fines gravel, washed aggregate, or cobbles.
- 4.0 Ideally, the CCS should be installed between May and October when the ground is driest and least prone to compaction. The approved wearing course is to be laid over the CCS. Where the new surface covers in excess of 20% of the RPA or is wider than 3m within the RPA, the new surface should be constructed in such a manner as to permit infiltration of moisture and gaseous diffusion. Government guidance now recommends permeable surfacing on most construction sites for drainage reasons and this should be considered for all hard surfacing within the RPA of retained trees.
- 5.0 The use of a non-woven Geotextile beneath the cellular mattress acts as a separation/filtration layer. The CCS should be filled with **no-fines** stone in the 20-40mm range. It is important that machinery is only used on the filled CCS and that it is not allowed to compact the soil within the RPAs of trees. Once filled, the perforated cellular wall structure provides mechanical interlock for infill materials, increasing the shear strength while allowing intercellular lateral free drainage.
- 6.0 The system is used as a permanent base for a wearing course and can also be used to provide a temporary site access. CCS material is available in thicknesses from 75mm to

Challice Consulting Ltd.

Holmwood Farm Grange Horsham Road North Holmwood Dorking Surrey RH5 4JR
Tel: 01306 743374 Email: info@challiceconsulting.co.uk Web: www.challiceconsulting.co.uk

300mm. The exact thickness required on a site will depend on soil type and the anticipated use of the surface. **A Structural Engineer should design all engineering solutions to surfaces and Geosynthetics offer a free design service.**

- 7.0 The entire RPAs of trees are fenced off at the outset of the project. The fencing is then re-aligned when the works are to commence to facilitate construction of the hard surface.

Stages for Installation of Low Invasive Surfaces

- Stage 1** **Erect tree protective fencing to cover entire RPAs of retained trees.**
- Stage 2** **Re-align tree protective fencing** just prior to work commencing to facilitate construction of low invasive surface. The tree protective fencing must then remain intact until all construction works are completed.
- Stage 3** **Remove surface vegetation** by using a specific herbicide (as advised by a specialist) or manually remove using hand tools. Light machinery operating from beyond the RPA and tree canopy of retained trees could, under specialist supervision, be used to carefully remove existing wearing surfaces, (the sub base of existing surfaces or foundations should be left in situ where possible). If the existing soil level is to be lowered, material is to be cleared away manually. Roots over 25mm in diameter, which are found within the construction profile, should not be severed, but be left in situ and covered immediately with soil or sharp sand to prevent desiccation.
- Stage 4** **Carry out final clearance under the canopies of retained trees.** This should be completed using hand forks (not spades) and any roots exposed should be cleanly cut and covered in soil/sharp sand immediately. Any delay to this process will require irrigation of any exposed roots and subsequent protection with dampened Hessian sacking or similar. Agreed removal of shrubs, saplings or trees, within the RPAs of retained trees should be cut to or just below ground level rather than pulled out, which can damage entwined roots.
- Stage 5** **Level out the ground if necessary** using sharp sand or topsoil (or a mixture thereof). This fills out any hollows in the ground and ensures a smooth surface for laying out of the Geotextile membrane. It is important not to use any machinery within the RPAs of the trees that could compact the soil.

Stage 6 Install the non-woven **Geotextile** directly over the soil surface and fix in place.



Stage 7 Lay **CCS** out over the **Geotextile membrane** and ensure edges are anchored open during the infill process with steel staples or wooden pegs.



Challice Consulting Ltd.

Holmwood Farm Grange Horsham Road North Holmwood Dorking Surrey RH5 4JR
Tel: 01306 743374 Email: info@challiceconsulting.co.uk Web: www.challiceconsulting.co.uk

Stage 8 **Fill the CCS,** ensuring machinery works only on already filled areas and not the sub grade. Typical infill consists of no fines angular granular material of 20-40mm in diameter.



Stage 9 **Install kerbs and edgings** directly on top of existing soil grade level. For light structures, a treated peg and board may be acceptable. For more substantial structures, railway sleepers, drilled kerbstones or gabions, held in place with track or road pins are more suitable. Edgings can be formed using bent reinforcing sheets if required (see diagram below).



Stage 10 **Install permeable surface**

Surfacing Options

Block Paving

- Lay a second layer of Geotextile separation fabric over the infill CCS.
- Lay a sharp sand bedding layer compacted with a vibro-compaction plate to recommended depth.
- Place block paviors as per manufacturer's instructions.

Loose Gravel

- Place second layer of Geotextile separation fabric over the infill CCS.
- Place pea shingle/ gravel to required depth.

Permeable Tarmac

- Lay as per manufacturer's recommendations on top of CCS

Makeup of Final Surface

(Images used with the kind permission of Geosynthetics Ltd, 01455 617139, www.geosyn.co.uk)

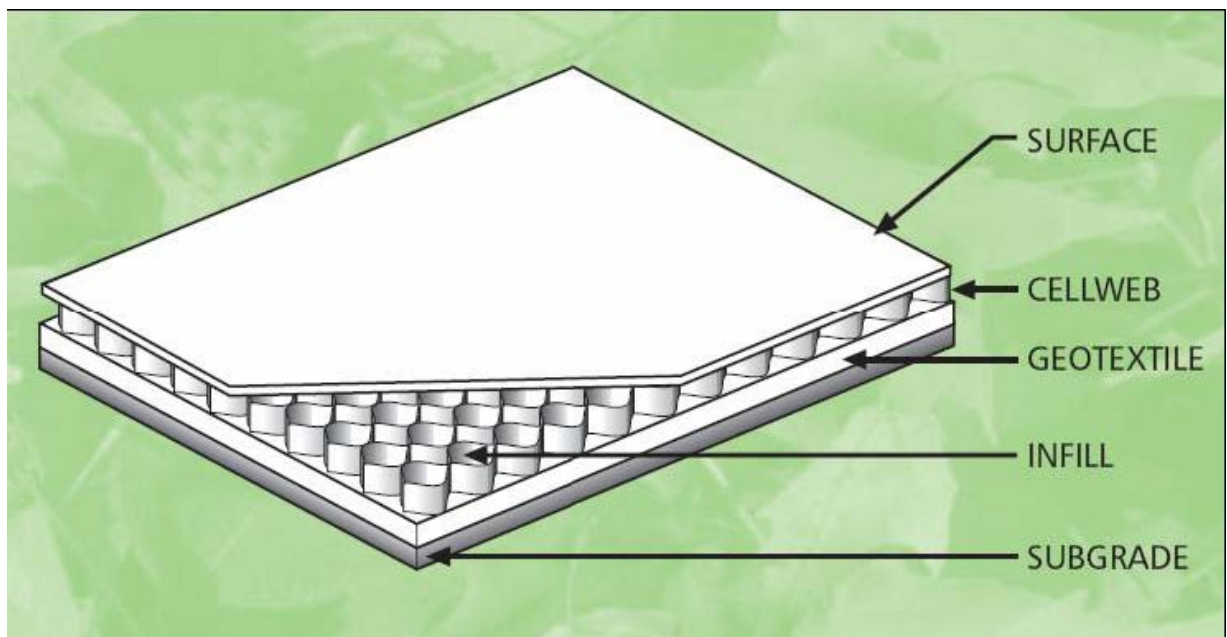

Challice Consulting Ltd.

Holmwood Farm Grange Horsham Road North Holmwood Dorking Surrey RH5 4JR
Tel: 01306 743374 Email: info@challiceconsulting.co.uk Web: www.challiceconsulting.co.uk