

Application reference: 21/2940/PS192 SOUTH TWICKENHAM WARD

Date application received	Date made valid	Target report date	8 Week date
19.08.2021	24.08.2021	19.10.2021	19.10.2021

Site:

11 Heath Gardens, Twickenham, TW1 4LY,

Proposal:

L-shape rear dormer roof extensions.

Status: Pending Consideration (If status = HOLD please check that all is OK before you proceed any further with this application)

APPLICANT NAME

Mr Alex Beale
11, Heath Gardens
Twickenham
TW1 4LY

AGENT NAME

Mr Alberto Ochoa
International House
Canterbury Crescent
Brixton
London
SW9 7QD

DC Site Notice: printed on and posted on and due to expire on

Consultations:**Internal/External:****Consultee****Expiry Date****Neighbours:**

-

History: Development Management, Appeals, Building Control, Enforcements:Development Management

Status: PCO

Date:

Application:21/2939/HOT

Proposed ground floor wraparound, floor plan redesign and all associated works

Development Management

Status: PCO

Date:

Application:21/2940/PS192

L-shape rear dormer roof extensions.

Building Control

Deposit Date: 21.07.2016

Install a gas-fired boiler

Reference: 16/FEN02193/GASAFE

Project Officer Report

Proposal

L-shaped rear dormer roof extension that would result in altering the existing rear chimney stacks as well as addition of No. 4 rooflights.

Site Description

The property is a two-storey semi-detached dwelling situated on the eastern side of Heath Gardens.

Such property is not located within a Conservation Area and it is not nationally listed.

Relevant Planning History

21/2939/HOT - Proposed ground floor wraparound, floor plan redesign and all associated works - Pending.

Planning Policies

The application will be assessed against Schedule 2, Part 1 of the Town and Country Planning (General Permitted Development) (England) Order 2015 (as amended), which relates to "Development within the curtilage of a dwellinghouse". These rights have not been removed or restricted by any previous planning conditions.

Assessment

The proposal falls under Class B – an addition or alteration to the roof.

Requirements under Class B	Compliance
B.1 Development is not permitted by Class B if -	
(a) Permission to use the dwellinghouse as a dwellinghouse has been granted only by virtue of Class M, N, P, PA or Q of Part 2 of this Schedule (change of use);	Compliant.
(b) any part of the dwellinghouse would, as a result of the works, exceed the height of the highest part of the existing roof;	Compliant. See Drawing No. B101378 - 02 - 3201 A.
(c) any part of the dwellinghouse would, as a result of the works, extend beyond the plane of any existing roof slope which forms the principal elevation of the dwellinghouse and fronts a highway;	Compliant.
(d) The cubic content of the resulting roof space would exceed the cubic content of the original roof space by more than - (i) 40 cubic metres in the case of a terrace house (ii) 50 cubic metres in any other case	Compliant. See the end of this report.
(e) It would consist of or include - (i) The construction or provision of a verandah, balcony or raised platform, or (ii) The installation, alteration or replacement of a chimney, flue or soil and vent pipe	Compliant. See Class G below.
(f) The dwellinghouse is on article 2(3) land	Not Applicable.
B.2 Development is permitted by Class B subject to the following conditions:	
(a) The materials used in any exterior work shall be of a similar appearance to those used in the construction of the exterior of the	Compliant.

existing dwellinghouse	
(b) The enlargement shall be constructed so that – (i) Other than in the case of a hip-to-gable enlargement or an enlargement which joins the original roof to the roof of a rear or side extension – (aa) the eaves of the original roof are maintained or reinstated; and (bb) the edge of the enlargement closest to the eaves of the original roof shall, so far as practicable, be not less than 0.2 metres from the eaves, measure along the roof slop from the outside edge of the eaves; and (ii) Other than in the case of an enlargement which joins the original roof to the roof of a rear or side extension, no part of the enlargement extends beyond the outside face of any external wall of the original dwellinghouse	Compliant. The edge of the enlargement closest to the eaves of the original roof would be not less than 0.2 metres from the eaves, measure along the roof slop from the outside edge of the eaves.
(c) Any window inserted on a wall or roof slope forming a side elevation of the dwellinghouse shall be – (i) Obscure-glazed, and (ii) Non-opening unless the parts of the windows which can be opened are more than 1.7 metres above the floor of the room in which the window is installed	Compliant.

The proposal falls under Class C – other alterations to the roof.

Requirements under Class C	Compliance
C.1 Development is not permitted by Class C if -	
(a) Permission to use the dwellinghouse as a dwellinghouse has been granted only by virtue of Class M, N, P, PA or Q of Part 2 of this Schedule (change of use);	Compliant.
(b) The alteration would protrude more than 0.15 metres beyond the plane of the slope of the original roof when measured from the perpendicular with the external surface of the original roof;	Compliant.
(c) It would result in the highest part of the alteration being higher than the highest part of the original roof;	Compliant.
(d) It would consist of or include- (i) The installation, alteration or replacement of a chimney, flue or soil and vent pipe, or (ii) The installation, alteration or replacement of solar photovoltaics or solar thermal equipment	Compliant.
C.2 Development is permitted by Class C subject to the condition that any window located on a roof slope forming a side elevation of the dwellinghouse shall be –	
(a) Obscure-glazed; and (b) Non-opening unless the parts of the window which can be opened are more than 1.7 metres above the floor of the room in which the window is installed	Compliant.

The proposal falls under Class G – chimney, flues etc.

Requirements under Class G	Compliance
G.1 Development is not permitted by Class G if -	
(a) permission to use the dwellinghouse as a dwellinghouse has been granted only by virtue of Class M, N, P, PA or Q of Part 3 of	Compliant.

<p>this Schedule (change of use);</p>	
<p>(b) the height of the chimney, flue or soil and vent pipe would exceed the highest part of the roof by 1 metre or more; or</p>	<p>Compliant.</p>
<p>(c) in the case of a dwellinghouse on article 2(3) land, the chimney, flue or soil and vent pipe would be installed on a wall or roof slope which-</p> <p>(i) fronts a highway, and</p> <p>(ii) forms either the principal elevation or a side elevation of the dwellinghouse.</p>	<p>Not Applicable.</p>

Summary:

The proposal is considered to be lawful within the meaning of s.192 of the Act, given the proposal meets the requirements of Classes B, C and G of the Town and Country Planning (General Permitted Development) (England) Order 2015 (as amended).

Recommendation:

It is recommended that application 21/2940/PS192 is supported, and a Lawful Development Certificate is issued.

Volume Calculation provided by the agent

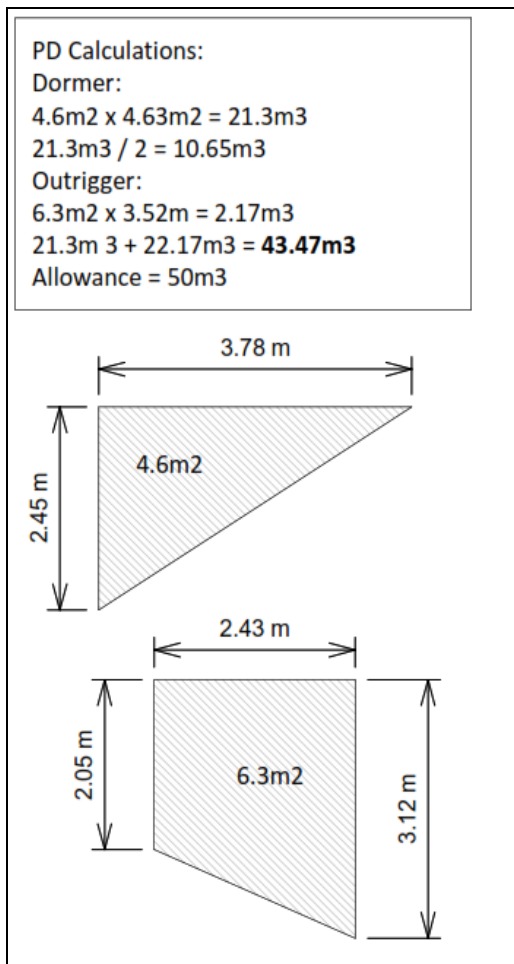

The above volume calculation has been checked by the Planning Officer and has found to be correct.

Recommendation:

The determination of this application falls within the scope of Officer delegated powers - **YES**

I therefore recommend the following:

- 1. REFUSAL
- 2. PERMISSION
- 3. FORWARD TO COMMITTEE

This application is CIL liable YES* NO
 (*If yes, complete CIL tab in Uniform)

This application requires a Legal Agreement YES* NO
 (*If yes, complete Development Condition Monitoring in Uniform)

This application has representations online (which are not on the file) YES NO

This application has representations on file YES NO

Case Officer (Initials): GAP Dated: 11/09/2021

I agree the recommendation: WT

~~Team Leader/Head of Development Management/Principal Planner~~

Dated:13/10/2021.....

This application has been subject to representations that are contrary to the officer recommendation. The Head of Development Management has considered those representations and concluded that the application can be determined without reference to the Planning Committee in conjunction with existing delegated authority.

Head of Development Management:

Dated:

REASONS:
CONDITIONS:
INFORMATIVES:
UDP POLICIES:
OTHER POLICIES:

The following table will populate as a quick check by running the template once items have been entered into Uniform

SUMMARY OF CONDITIONS AND INFORMATIVES

CONDITIONS

INFORMATIVES
