

0 1m 5m

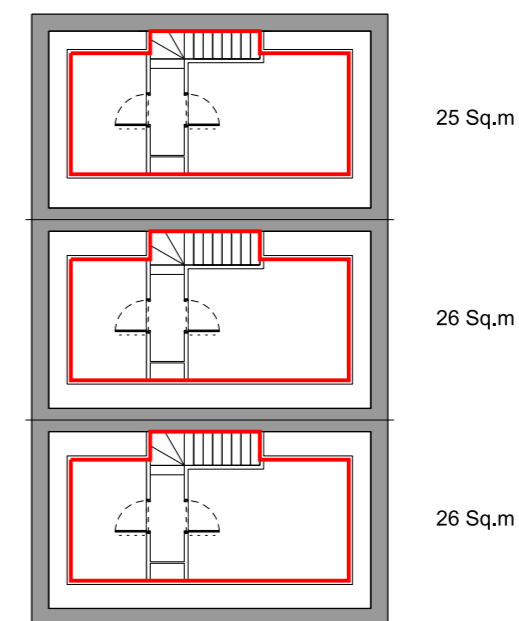

**AREA CALCULATIONS**

These areas have been measured from plans produced at stage 2 pre-planning and are approximate and illustrative only. Further development of the design, measurement and construction tolerances and/or further client/tenant requests will inevitably result in changes to these areas (which could involve significant reductions) and WP accept no legal responsibility for any decision, commercial or otherwise, made on the basis of these areas.

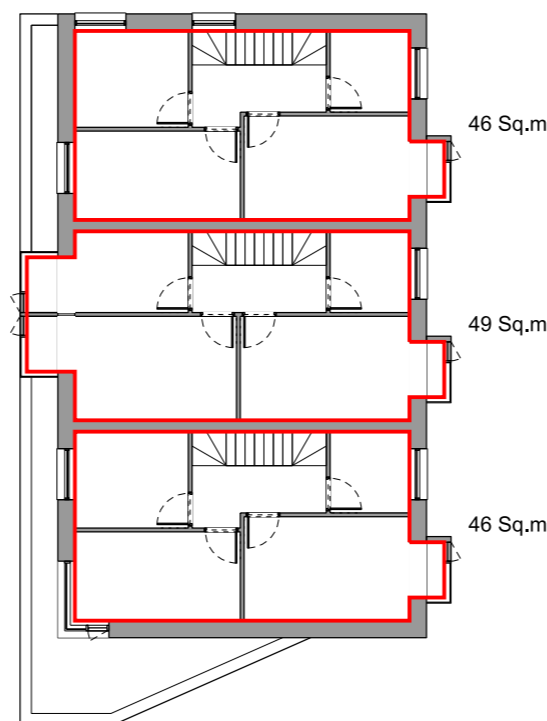
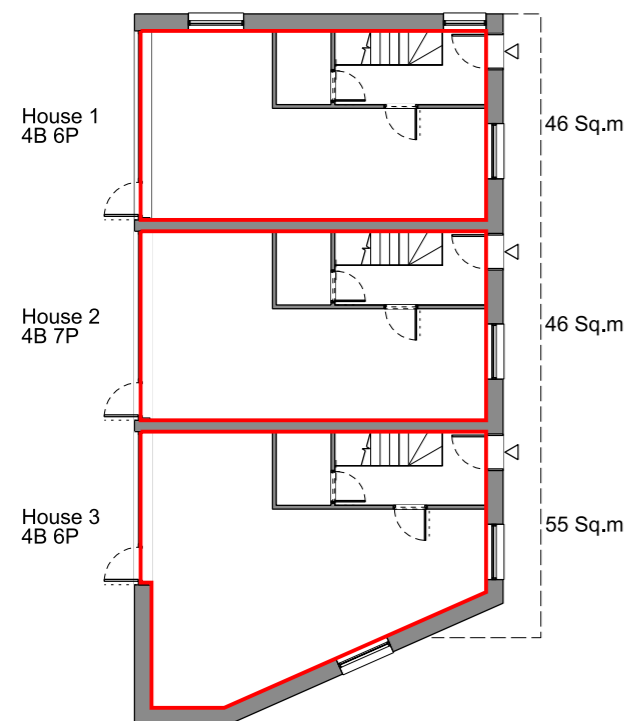

01  
0400 Ground Floor Areas

02  
0400 First Floor Areas

03  
0400 Second Floor Areas

GIA

P02	2022-11-03	Planning Update - Building footprint rotated & reduced
P01	2022-04-11	Planning Submission
Revision	Date	Description

© copyright Wimshurst Pelleriti, all rights reserved 2022

Do not scale-off this drawing. Wimshurst Pelleriti take no responsibility for any dimensions obtained by measuring or scaling from this drawing and no reliance may be placed on such dimensions, if no dimension is given. It is the responsibility of the recipient to ascertain the dimension specifically from the Architect or by site measurement.

The sizing of all structural and service elements must always be checked against the relevant engineers drawings. No reliance should be placed upon sizing information shown on this drawing.

**Existing planning application areas - 395 sqm**

Areas in Sqm	House 1 5B 8P	House 2 4B 6P	House 3 3B 6P
Ground	51*	44	52
1st	51*	48	42
2nd	42	34	31
<b>Total</b>	<b>144</b>	<b>126</b>	<b>125</b>

Minimum Required To Meet NDSS      134      112      108

\* Areas corrected.

**Proposed areas - 365 sqm**

Areas in Sqm	House 1 4B 6P	House 2 4B 7P	House 3 4B 6P
Ground	46	46	55
1st	46	49	46
2nd	25	26	26
<b>Total</b>	<b>117</b>	<b>121</b>	<b>127</b>

Minimum Required To Meet NDSS      112      121      112

**Project**  
St Margarets Business Centre  
Richmond, London

**Drawing Title**  
Area Schedule

**Drawing Number**      **Revision**  
WP-0780-A-0400-P-XX      2022-11-03

**Scale @ A3**      **Revision Date**  
1:200      P2

**Drawing Purpose**  
PLANNING

**WIMSHURST PELLERITI**

The Mews,  
6 Putney Common, SW15 1HL  
0208 780 2206  
Info@wp.uk.com  
wimshurst-pelleriti.com

