

USE OF DRAWINGS

DO NOT SCALE FROM THIS DRAWING. USE WRITTEN DIMENSIONS AND CHECK ON SITE. THIS DRAWING IS BASED ON SITE INFORMATION SUPPLIED BY THIRD PARTIES AND ACCURACY OF EXISTING FEATURES IS NOT GUARANTEED. ANY ERROR, OMISSION OR DISCREPANCY NOTED ON OR BETWEEN DRAWINGS AND OTHER DOCUMENTS MUST BE REPORTED IN WRITING IMMEDIATELY. ALL MECHANICAL, ELECTRICAL AND STRUCTURAL LAYOUTS / COMPONENTS ARE INDICATIVE AND MUST BE DESIGNED AND CHECKED BY SPECIALISTS. DO NOT START WORK ON SITE BEFORE CONFIRMING THAT ALL NECESSARY STATUTORY AND OTHER CONSENTS HAVE BEEN OBTAINED. THIS DRAWING IS COPYRIGHT AND MUST NOT BE DISTRIBUTED WITHOUT PERMISSION. ELECTRONIC CAD FILES MUST NOT BE ALTERED OR COPIED.

REVISIONS

REV	DATE	DESCRIPTION	CHECKED DRAWN
-	11.10.2019	INITIAL ISSUE	MC KW
A	04.11.2019	CHANGES TO ROOF EXTENSION	MC KW
B	04.05.2020	CHANGES TO LEVELS & EAVES, SHADING ASSEMBLIES ADDED	SJ RH
C	25.07.2022	DESIGN REVIEW AMENDMENTS	LW JF
D	26.05.2023	HISTORIC ENGLAND FOR COMMENT	JF JF
E	21.07.2023	DOOR AND WINDOW UPDATE	LW JF

NOTE:
 - DRAWINGS ARE DESIGN INTENT FOR THE PURPOSE OF PLANNING APPROVAL.
 - ALL DRAWINGS ARE SUBJECT TO FURTHER DESIGN DEVELOPMENT AND COORDINATION WITH ENGINEERS INFORMATION.
 - ALL FURNITURE AND INTERIOR LAYOUTS ARE INDICATIVE AND SUBJECT TO DETAILED DESIGN.
 - EXISTING HERITAGE BRICK AND STONE FAÇADES TO BE CLEANED AND RESTORED.
 - INTERNAL VOLUMES TO BE STRIPPED OUT, REMOVING 20TH C. WORK AND RESTORING ORIGINAL FABRIC.
 - INDUSTRIAL HERITAGE DETAILS - TILES, BRICKS, ELECTRICAL SWITCHES, LIFTING CRANES, ETC. - TO BE CLEANED AND RETAINED.
 - ALL EXISTING ORIGINAL WINDOWS TO BE RETAINED AND RESTORED, WITH NEW HIGH-PERFORMANCE SECONDARY GLAZING INSERTED BEHIND.
 - ALL EXISTING WINDOWS WHICH ARE NOT ORIGINAL TO THE BUILDING TO BE REPLACED WITH HIGH PERFORMANCE WINDOWS TO MATCH EXISTING DESIGN.

IN PROGRESS

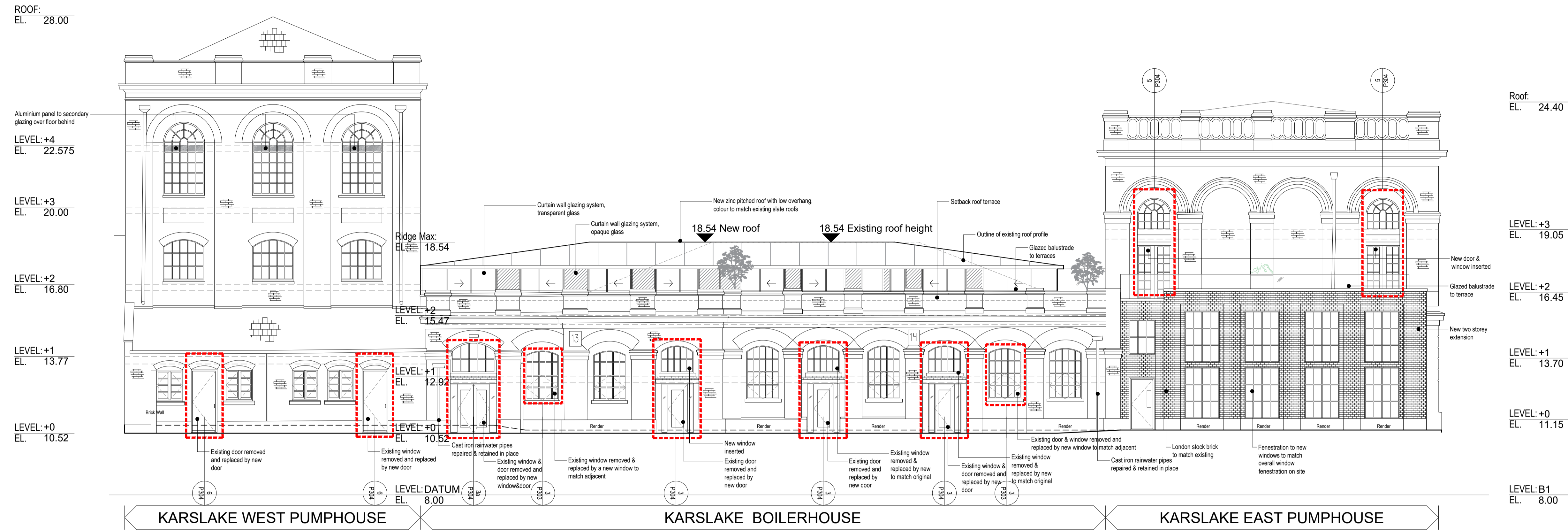

SCALE 1:100
KARSLAKE - Elevation 1

- Proposed internal levels
- Changes to existing facade
- Opaque panel to secondary glazing
- Opaque glazing

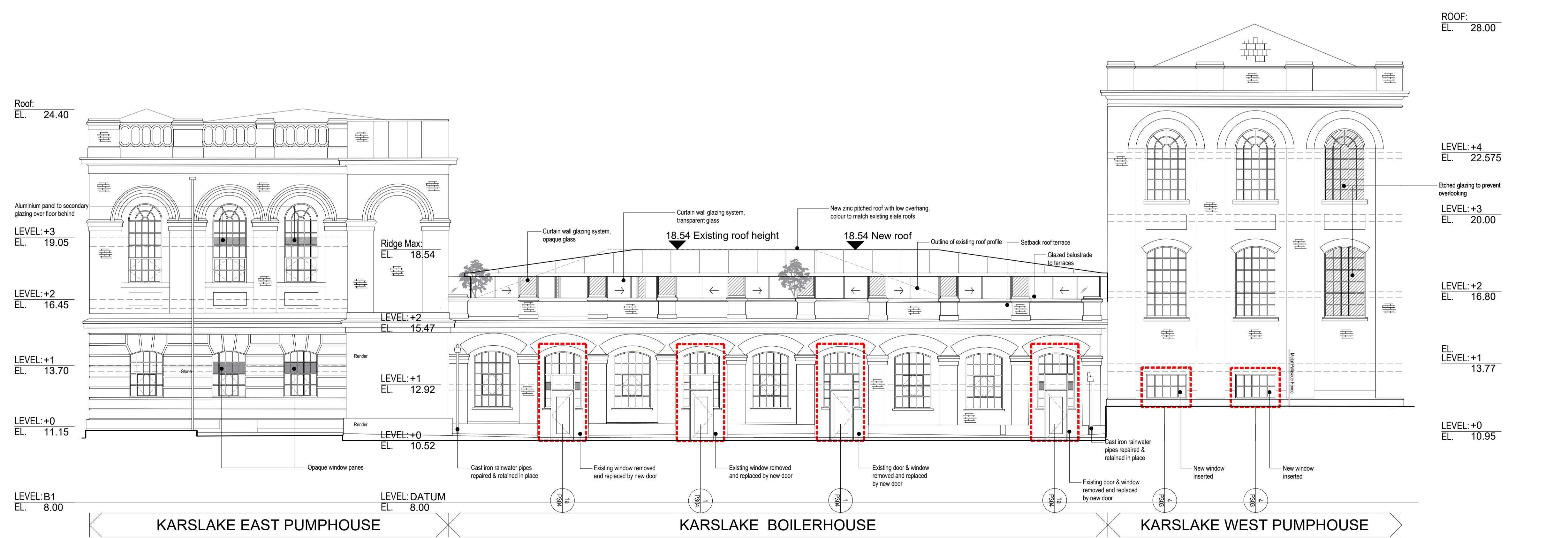
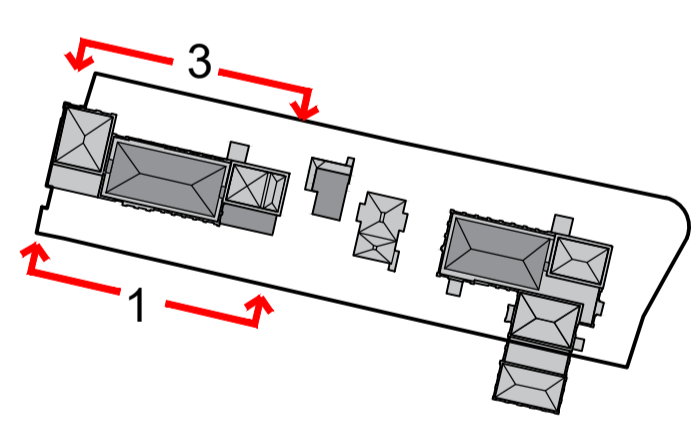

SCALE 1:100
KARSLAKE - Elevation 3



client
WATERFALL
PLANNING LTD

project
HAMPTON WATERWORKS

drawing title
PROPOSED ELEVATIONS -
KARSLAKE SHEET 01

sheet size scale
A1 1:100 @ A1

status
PLANNING

drawing no. revision
1685-A-P201 E

LOM architecture and design
The Glass House 5 Sclater Street London E1 6JY UK
Phone +44(0)20 8444 2999 Email mail@lom-fdp.com
Web www.lom-architecture.com

