

## Stag Brewery, Mortlake

### Technical Note 16 – Sheen Lane Level Crossing Analysis



On behalf of **Reselton Properties**

Project Ref: 38262/5501 | Rev: B | Date: April 2021

Registered Office: Buckingham Court Kingsmead Business Park, London Road, High Wycombe, Buckinghamshire, HP11 1JU  
Office Address: 78 Cowcross Street, London, EC1M 6EJ  
T: +44 (0)203 824 6600 E: PBA.London@stantec.com

## Document Control Sheet

**Project Name:** Stag Brewery, Mortlake  
**Project Ref:** 38262/5501  
**Report Title:** Sheen Lane Level Crossing Analysis  
**Doc Ref:** 38262/GLC/RWP/NM/HM/170119/TN016  
**Date:** December 2017

	Name	Position	Signature	Date
<b>Prepared by:</b>	H Metcalf N Newe	Graduate Engineer Senior Engineer	<i>H Metcalf</i> <i>N Newe</i>	December 2017
<b>Reviewed by:</b>	R Parker	Director of Transport Planning	R Parker	December 2017
<b>Approved by:</b>	G Callaghan	Partner	G Callaghan	December 2017
<b>For and on behalf of Stantec UK Limited</b>				

Revision	Date	Description	Prepared	Reviewed	Approved
A	19.01.17	For Issue	HM/NN	RP	GC
B	12.04.21	Update to Enlarged Scheme	MB	PW	GC

This report has been prepared by Stantec UK Limited ('Stantec') on behalf of its client to whom this report is addressed ('Client') in connection with the project described in this report and takes into account the Client's particular instructions and requirements. This report was prepared in accordance with the professional services appointment under which Stantec was appointed by its Client. This report is not intended for and should not be relied on by any third party (i.e. parties other than the Client). Stantec accepts no duty or responsibility (including in negligence) to any party other than the Client and disclaims all liability of any nature whatsoever to any such party in respect of this report.

## Contents

<b>1</b>	<b>Introduction .....</b>	<b>1</b>
1.1	Background .....	1
1.2	Structure .....	1
<b>2</b>	<b>Mortlake Level Crossing.....</b>	<b>2</b>
2.1	Overview.....	2
2.2	Location .....	2
2.3	Rail Services.....	3
2.4	Level Crossing and Station .....	3
2.5	Existing Usage.....	5
2.6	Barrier Down-Times.....	7
<b>3</b>	<b>Safety Review .....</b>	<b>8</b>
3.1	Background .....	8
3.2	Network Rail Review of Safety Risks .....	8
3.3	Stantec Accident Data Analysis .....	9
3.4	Future Safety Conditions.....	10
<b>4</b>	<b>Level Crossing Usage.....</b>	<b>12</b>
4.1	Overview.....	12
4.2	Stag Brewery Development Proposals.....	12
4.3	Trip Generation.....	13
4.4	Highway Impact Assessment .....	13
4.5	Assessment of Pedestrian Demand .....	16
4.6	Trip Distribution .....	16
4.7	Trip Summary at Level Crossing .....	19
<b>5</b>	<b>Impact Assessment.....</b>	<b>21</b>
5.1	Overview.....	21
5.2	Pedestrian Demand Flows .....	21
5.3	Review of Bridge and Staircase Capacity .....	21
5.4	Mortlake Staircase.....	22
5.5	Review of Mortlake Level Crossing.....	23
5.6	Summary .....	24
<b>6</b>	<b>Options for Improving Safety.....</b>	<b>25</b>
6.1	Overview.....	25
6.2	Existing Safety Conditions.....	25
6.3	Discussion .....	26
6.4	Potential Strategy .....	27
<b>7</b>	<b>Summary and Conclusion .....</b>	<b>28</b>
7.1	Summary .....	28

## Figures

Figure 2.1: Strategic Location Plan .....	2
Figure 2.2: Looking South-East Over the Level Crossing .....	3
Figure 2.3: Looking North-East Over the Level Crossing.....	3
Figure 2.4: The western footpath across the Level Crossing.....	4
Figure 2.5: Dimensions of Sheen Lane Level Crossing and Footbridge.....	4
Figure 2.6: The View from the Camera .....	5
Figure 2.7: Flows Recorded in Video Footage and Pedestrian Survey .....	6
Figure 2.8: Existing AM Peak Hour Flows.....	6
Figure 3.1: Collision Data Study Area .....	10
Figure 4-1: AM Peak Development Traffic Distribution .....	14
Figure 4-2: PM Peak Development Traffic Distribution .....	15
Figure 4.1: Catchment areas (south of the railway) for each crossing.....	18

## Tables

Table 2.1: Level Crossing Surface Dimensions (metres).....	5
Table 2.3: Existing AM Peak Hour Pedestrian Movements at the Level Crossing and Footbridge .....	7
Table 2.4: Average Recorded Level Crossing Barrier Down Times During Daytime Hours .....	7
Table 4.1: Stag Brewery Land Uses and Quanta.....	12
Table 4.4: Development Forecast AM Peak Hour Pedestrian and Cycle Trips .....	16
Table 4.5: Development Forecast AM Peak Hour Rail Trips to Mortlake Westbound Platform.....	17
Table 4.6: Development Walking Trips at Level Crossing and Footbridge (AM peak hour) .....	20
Table 5.1: Notional and Required Width of Mortlake Footbridge .....	22
Table 5.2: Notional and Required Width of Mortlake External Staircase .....	22
Table 5.3: Train Pedestrian Values during the AM Peak Hour .....	23
Table 5.4: ORR's Pedestrian Categories for Level Crossing.....	23
Table 5.5: Mortlake Level Crossing TPVs and associated Categories .....	24

## Appendices

Appendix A	NR Risk Assessment' (July 2017)
Appendix B	NR letter to Zac Goldsmith MP

This page is intentionally blank

# 1 Introduction

## 1.1 Background

- 1.1.1 This Note has been prepared to address safety concerns raised by Network Rail (NR) relating to increased usage of the Mortlake Level Crossing as a result of the proposed Stag Brewery development. These concerns were reported in NR's 'Mortlake Level Crossing Risk Assessment' (July 2017) and NR's letter to Zac Goldsmith MP (26 October 2017), copies of which can be found in Appendix A and Appendix B respectively.
- 1.1.2 The assessment looks at all modes of movement that would use the crossing. As part of the wider transport assessment of the Stag development proposals, a spreadsheet model has been developed to provide estimates of trips by mode throughout the day. This includes estimates of likely increased use of the Mortlake Railway Station by direction of travel. Outputs from this trip generation assessment have been used to estimate increased demand at the crossing by vehicles, pedestrians, cyclists and by those accessing or departing the stations westbound platform.
- 1.1.3 The first iteration of this Note (Revision A) was prepared to support the 2018 Planning Application referred to as the London Borough of Richmond upon Thames (LBRuT) resolved position. Following comments from Transport for London (TfL) this note (Revision B) was prepared in 2021 to update the trip generation analysis associated with the enlarged GLA Refused Scheme and uses the revised trips to assess their potential impact on the Sheen Lane railway Level Crossing.
- 1.1.4 During the development of both schemes (LBRuT resolved and GLA determined), Stantec and previously as PBA, worked closely with LBRuT and TfL officers to agree trip generation estimates and impacts. The traffic impacts of the proposed development have been tested using Transport for London's (TfL) strategic SOLHAM model which provides estimates of traffic demand and journey times for journeys across the Level Crossing.
- 1.1.5 In assessing pedestrian demand, we have considered the overall demand to cross the railway line between A205 Clifford Avenue (South Circular) and White Hart Lane (the location of the next Level Crossing to the east) and identified likely usage of the different crossings that are available, based upon a first principles methodology.

## 1.2 Structure

- 1.2.1 This remainder of this Note is structured as follows:
- Section 2 describes the existing crossing including current demand to use both the footbridge and crossing based recent surveys
  - Section 3 provides a review of safety and sets out the concerns expressed by NR in their report and letter
  - Section 4 provides an assessment of the likely increase in demand to use the Level Crossing by all modes that will occur as a result of the proposed development
  - Section 5 provides an assessment of the likely safety implications that would arise from this increase in demand
  - Section 6 identifies the options for improving the management of pedestrians and traffic at the crossing and for improving safety levels
  - Section 7 provides a summary and conclusions to the work undertaken



## 2 Mortlake Level Crossing

### 2.1 Overview

2.1.1 This section describes the existing characteristics of the Level Crossing and the associated Mortlake Railway Station. The locational context of the crossing in relation to the Stag Brewery Development site and the presence of other crossing points is explained together with a description of the physical characteristics of the Level Crossing. The existing demand, both to cross the rail line and to enter the station are based on pedestrian and vehicle surveys commissioned to inform this assessment.

### 2.2 Location

2.2.1 The Mortlake Level Crossing is located on Sheen Lane, a high street with numerous shops and local amenities including a library, primary school and health care centre. Figure 2.1 shows the location of Mortlake station and Level Crossing in relation to its wider surrounding area including the Stag Brewery development site as well as other Level Crossings and footbridges over the railway tracks. It is subject to a 30 mph speed limit for vehicles.

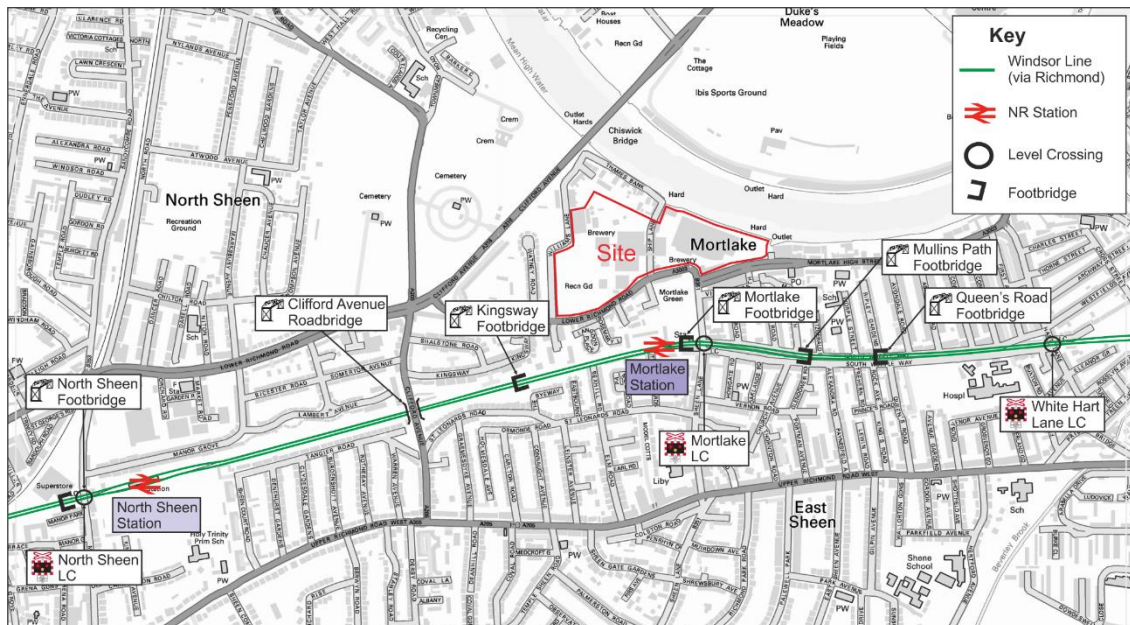

Figure 2.1: Strategic Location Plan

2.2.2 The Level Crossing itself is crossed in a north-south direction along Sheen Lane which provides a link between the A3003 Lower Richmond Road and the A205 South Circular Road as shown in Figure 2.1. Both roads follow an east-west alignment. The South Circular is a Red Route forming part of London's strategic road network. The A3003 has a mainly local function providing access to Mortlake and Barnes

2.2.3 The figure also shows that between A205 Clifford Avenue and White Hart Lane (the extents of the study area) there are a number of options for crossing the railway line in addition to the Level Crossing. From east to west these are as follows:

- White Hart Lane Level Crossing
- Queens Road footbridge
- Mullins Path footbridge
- Mortlake station footbridge
- Kingsway footbridge
- Clifford Avenue Road bridge

2.2.4 Whilst Sheen Lane and its crossing provide the most direct access between the development site, the station and to the facilities along Sheen Lane they do not necessarily provide the most direct link to the residential areas to the south of the railway line and the new facilities that would be available within the site. In particular, the Kingsway footbridge will be the most direct access for many wishing to access the western part of the site, including the new school whilst the footbridges to the east of Sheen Lane will be more convenient for many of those living to the east of the station.

## 2.3 Rail Services

2.3.1 The Mortlake Level Crossing lies on the Windsor Lines (via Richmond). The majority of trains using this route are passenger trains operated by the South Western Railway (SWR) franchise although a small number of freight trains use the route as well. All passenger trains originate at London Waterloo and travel west over the Level Crossing towards Richmond.

2.3.2 Immediately to the west of the Level Crossing is Mortlake station where 8 trains per hour call and an additional 4 trains per hour pass through during a typical daytime hour. In total, 349 trains pass through Mortlake on a typical day and all trains are subject to a speed restriction of 60 mph.

## 2.4 Level Crossing and Station

2.4.1 Mortlake Level Crossing is a CCTV monitored crossing that is manually controlled by a signaller in the Feltham signal box. This form of protection is referred to as CCTV-MCB. The four-barrier layout is shown in Figure 2.2 and Figure 2.3.

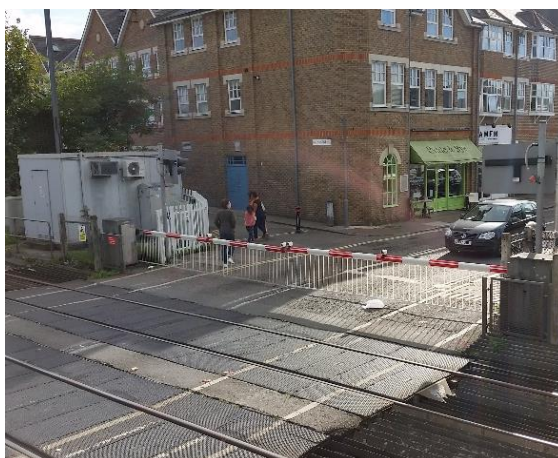

Figure 2.2: Looking South-East Over the Level Crossing



Figure 2.3: Looking North-East Over the Level Crossing

2.4.2 A marked footway runs across the eastern side of the LC and an identical marked footway across the western side of the LC as shown in Figure 2.4.





Figure 2.4: The western footpath across the Level Crossing

- 2.4.3 The station includes a footbridge which provides an alternate route for pedestrians to cross the railway line when the barriers at the crossing are down. The footbridge is accessible via staircases off Sheen Lane's western footway adjacent to the Level Crossing barriers. There are separate stairs down to platform level. There is no provision for disabled access. The Level Crossing, in effect, provides step free access between the two platforms.
- 2.4.4 A detailed plan outlining the dimensions of the Level Crossing and footbridge is shown in Figure 2.5.

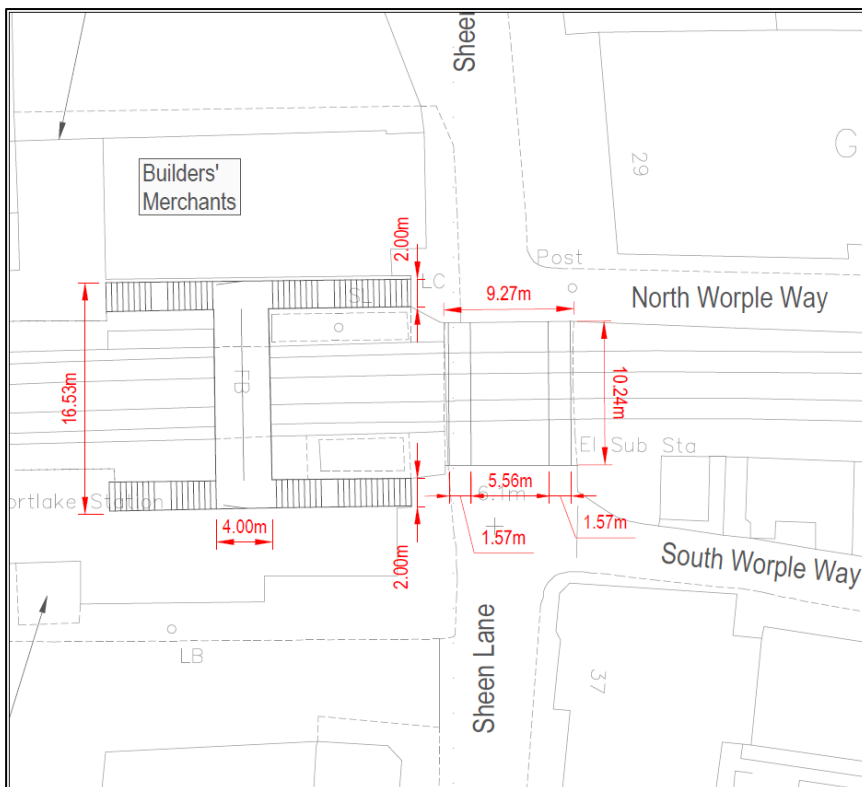

Figure 2.5: Dimensions of Sheen Lane Level Crossing and Footbridge

2.4.5 Table 2.1 summarises the dimensions of the Level Crossing and Table 2.2 summarises the footbridge dimensions.

Table 2.1: Level Crossing Surface Dimensions (metres)

Dimension	Length (m)
Carriageway Width (including marker footways)	9.27
Length (between barriers)	10.24
Footway Width (marked)	1.57

Table 2.2: Footbridge Dimensions

Dimension	Length (m)
Length	16.60
Width	4.00
Staircase Width	2.00

## 2.5 Existing Usage

### Traffic Demand

2.5.1 A traffic survey undertaken on 15<sup>th</sup> June, 2016 indicated a total two-way flow of 491 passenger car units (pcu) during the AM peak hour (08:00 to 09:00) across the Level Crossing. The recorded northbound flow (286 pcu) was slightly higher than the recorded southbound flow (205 pcu)

### Pedestrian Demand

2.5.2 The current usages of both the Level Crossing and footbridge were recorded in video surveys between 26-27 June 2017. The video camera was located on the north-eastern side of the Level Crossing looking southwards given the view shown in Figure 2.6.



Figure 2.6: The View from the Camera

2.5.3 This enabled the counting of pedestrians across the Level Crossing. A separate survey was conducted on 15 June 2016 to capture the volume of pedestrians using the footbridge. Based

on these surveys, the number of pedestrians entering the station at each of the four locations or crossing the railway line via the Level Crossing or footbridge have been identified for the AM peak hour (08:00 to 09:00 as shown in Figure 2.7, The surveys did not specifically record the number of people using the internal stairways as a means of crossing between platforms. It is clear that during the morning peak a substantial number of people enter the station via the main entrance and then use the footbridge to access the eastbound platform. This has been taken into account by adjusting the flow figures to ensure that the total boardings from the eastbound platform are equal to 78% of total station boardings during the AM peak, in line with the data for the station provided by NR.

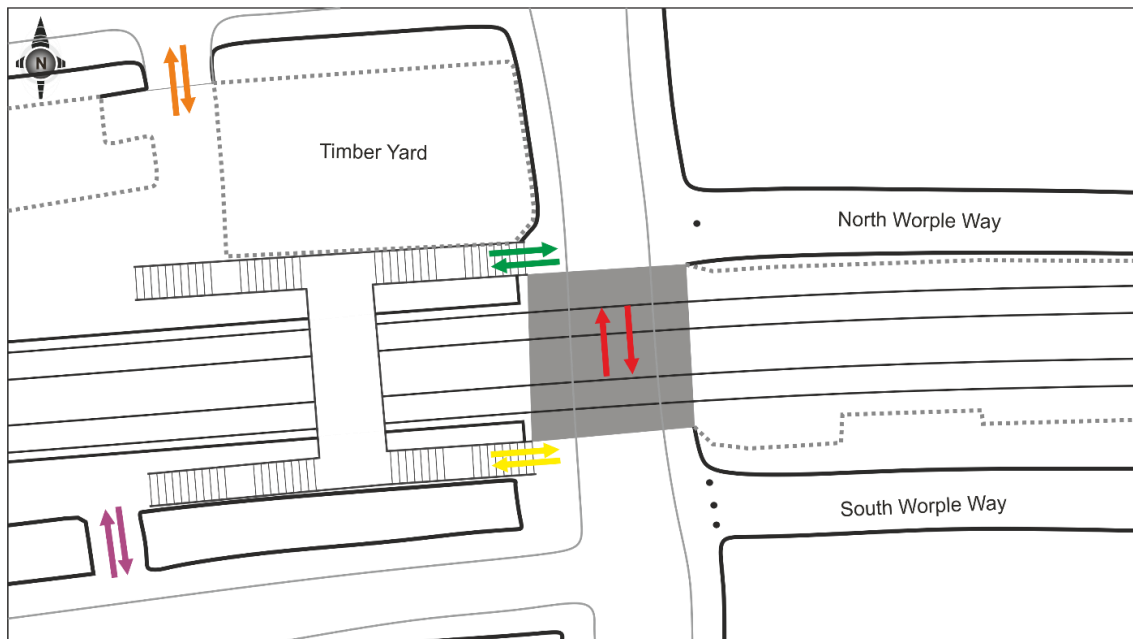

Figure 2.7: Flows Recorded in Video Footage and Pedestrian Survey

2.5.4 Based on this assessment the existing AM peak hour pedestrian flows are shown in Figure 2.8.

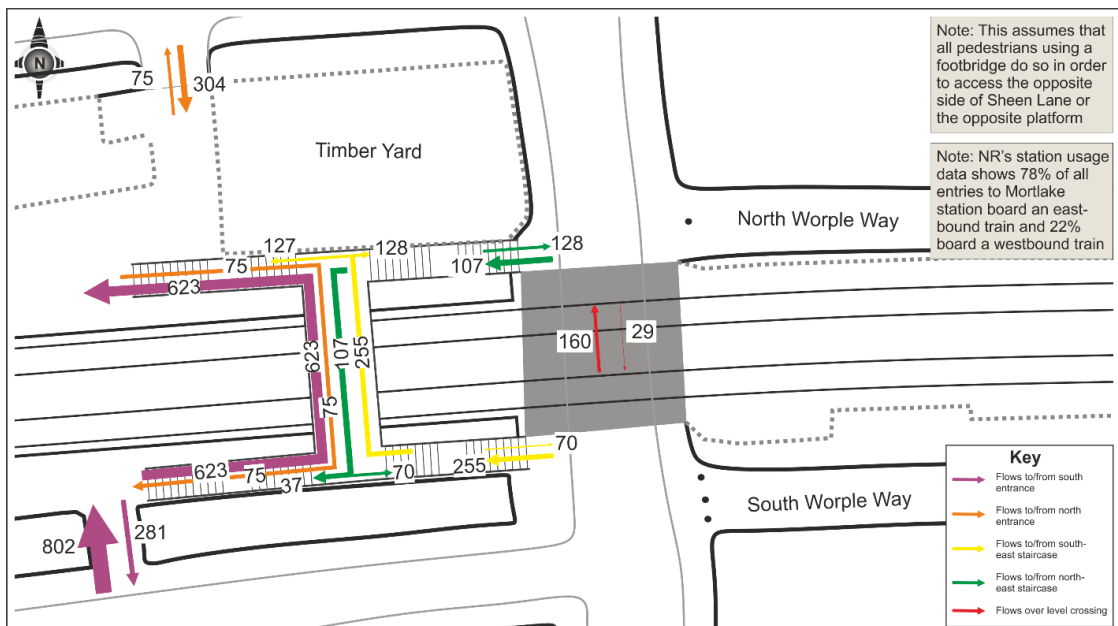

Figure 2.8: Existing AM Peak Hour Flows

2.5.5 Table 2.3 shows the existing AM peak demands at the Mortlake Level Crossing and footbridge.

Table 2.3: Existing AM Peak Hour Pedestrian Movements at the Level Crossing and Footbridge

Location	Northbound	Southbound	Two-Way
Level Crossing	160	29	189
Footbridge	878	182	1060
North side external stair	128	107	235
South side external stair	255	70	325
North side internal stair	750	75	825
South side internal stair	623	112	735

## 2.6 Barrier Down-Times

2.6.1 The Level Crossing barrier down times for daytime hours, as presented in NR's 'Mortlake Level Crossing Risk Assessment' (July 2017), are shown in Table 2.4 below.

Table 2.4: Average Recorded Level Crossing Barrier Down Times During Daytime Hours

Down Time	Full day (mm:ss)	Peak Hour (mm:ss)
Average Barrier Down Time	03:59	04:26
Average Barrier Down Time Per Hour	40:39	46:32

2.6.2 Similar durations, showing very long barrier down times of between 40 and 46 minutes, were also recorded in surveys commissioned by Stantec in 2017.



## 3 Safety Review

### 3.1 Background

- 3.1.1 This section sets out the safety concerns expressed by Network Rail (NR) in their report “Mortlake Level Crossing Risk Assessment” dated 26<sup>th</sup> July 2017 and a subsequent letter dated 28<sup>th</sup> October 2017 from Stewart Firth, Director of Route Sponsorship, Wessex. The latter was addressed to Mr Goldsmith, then Member of Parliament for Richmond Park. Both are attached at Appendix A and Appendix B respectively.
- 3.1.2 The report and letter also set out potential options for improvement and these are summarised and considered within Section 5.
- 3.1.3 Stantec has also been in direct contact with NR to better understand their concerns and a meeting was held with representatives on 4 August 2017. A meeting was also convened by Mr Goldsmith, MP on 15<sup>th</sup> September 2017, to discuss the matter and options for addressing safety concerns and this was attended by officers of LBRuT, London Buses as well as NR. Representatives of the Stag Development were also present. The outcome of these meetings is also reported.
- 3.1.4 Finally, a summary is provided of reported injury accidents along Sheen Lane in the five years to 31<sup>st</sup> January 2016 including a review of their potential association with the Level Crossing.

### 3.2 Network Rail Review of Safety Risks

- 3.2.1 The NR Risk Assessment provides details of a snapshot survey undertaken by NR to assess existing demand; this was a 30-minute duration survey undertaken from 10:40hrs on 5<sup>th</sup> October 2016. The report also confirms the number of trains using the crossing on a daily basis as well as an analysis of barrier down time (previously summarised above in Table 2.4).
- 3.2.2 The report states that deliberate miss use of the crossing, either by vehicles or by pedestrians is “prolific and almost occurs on a daily basis. The report provides two tables of incidents to back this up:
- Table 2.6 provides a table showing recorded incidents between 16 July 2016 and 18 February 2017. This shows details of seven incidents but it is not clear if this is a comprehensive list and how the list has been compiled;
  - On pages 8 and 9 there is a list “tasking dates”, presumably observation/enforcement by British Transport Police (BTP). This covers the period 6<sup>th</sup> December 2012 to 12<sup>th</sup> June 2017 with observations on 45 days of between 1:00 hour and 7 hrs 45 minutes (but more typically 3 to 4 hours per visit). It lists the observed numbers of both offending drivers and offending pedestrians.
- 3.2.3 The BTP data is interesting in that the number of recorded offences appears to have been particularly high during 2014 and 2015 but then reduced significantly during 2016 and 2017, which would include the period after the new extension to Thomson House School (which caters for years 1 to 3) opened just to the north of the rail line. However, the report provides no analysis of this data or explanation of why these trends might have occurred.
- 3.2.4 The report makes a number of interesting points:
- That the recoded miss-use “is similar to other crossings in the area or, comparable CCTV crossings situated in congested urban environments”;
  - “The barrier downtime at the crossing is lengthy and thus likely to be a contributory factor in deliberate misuse terms”
- 3.2.5 The report then gives a summary of its risk assessment. This is based upon its risk assessment model “All Level Crossing Risk Model (ALCRM)”. This appears to be a highly



theoretical assessment of risk which calculates an overall risk score based upon the number of incidents recorded and the number of users of a crossing.

3.2.6 Based on this model, the report states that the crossing is “the 4<sup>th</sup> riskiest CCTV crossing on the Wessex Route and places it in the high risk category. It notes that the key risk drivers were train frequency, that the crossing is near a station (it does not clarify how this affects the risk factors) and the large number of users. However, it is also noted that the report cautions that “The ALCRAM tool can give a rather limited output of hazards around residual risk or misuse. It is not possible to use ALCRAM to properly assess risk from a wide range of hazards.”

3.2.7 Whilst the report states that there are high risks to pedestrians, road users and train passengers it also notes that “the majority of risk is controlled by the full barriers separating road users from trains and the signaller protecting the crossing ensuring that a train cannot approach unless the crossing is clear”.

3.2.8 NR clarify their concerns in their conclusions. They state that:

“The main risk is a vehicular risk to pedestrians from general road users and more so road users that deliberately misuse the crossing. This is not helped by the current width of the footpaths on both approaches and specifically user congestion during peak hours.”

3.2.9 The subsequent letter from NR simply refers to the above report and provided no further information or clarification regarding the current safety risks. No additional risk information was forthcoming either at the meeting attended by Stantec in August or at the meeting convened by Mr Goldsmith MP.

### 3.3 Stantec Accident Data Analysis

3.3.1 Stantec has conducted an analysis of road collisions in the study area shown in Figure 3.1 which includes Sheen Lane and the Level Crossing. Transport for London (TfL) have provided Stantec with this data on three different occasions. The first period covered was the five-year period to 31 January 2016. The second for the three years leading up to October 2019 and finally from October 2019 to September 2020, which is the latest data. This demonstrates the majority of collisions occur along the South Circular road corridor with very few collisions recorded along Sheen Lane.

3.3.2 A detailed analysis of the first set of data has shown that one slight accident occurred immediately to the north of the Level Crossing and one immediately to the south. The first involving a vehicle passenger trapping their foot in the car door while exiting the vehicle and the second a vehicle reversing into another, causing a collision. These accidents reflect poor driver behaviour. The latter could relate to driver frustration relation to the Level Crossing although this is not clear from the description.

3.3.3 The second set of data from 2016 – 2019 indicated two slight incidents occurred near the Level Crossing on Sheen Lane. One involving a cyclist and one involving a pedestrian. The information provided indicates that it was not known how either collision occurred.

3.3.4 The final set of data indicates that there were no collisions in the proximity of the Level Crossing within the most recent period.

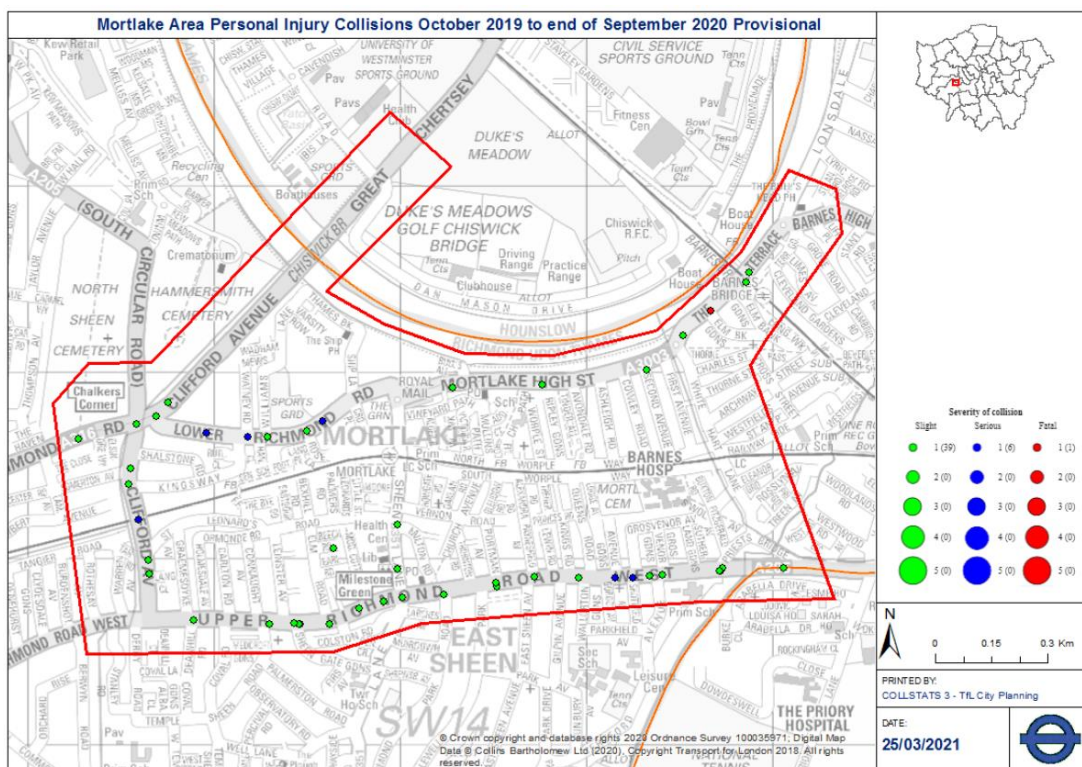

Figure 3.1: Collision Data Study Area

### 3.4 Future Safety Conditions

- 3.4.1 Based on their Risk Assessment, NR's prime concern appears to relate to the potential for accidents to occur between vehicles and pedestrians, in part related to the deliberate misuse of the crossing. The Risk Assessment suggest that this is at least in part associated with the long barrier down time and associated frustrations of drivers and pedestrians.
- 3.4.2 There is also suggestion in NR's recent letter that "pedestrian movement is already near maximum capacity and any further increase would compromise safety in relation to user interaction". However, NR has provided no analysis of existing pedestrian demand at the crossing and consequently this statement is not justified either within the report or the subsequent letter.
- 3.4.3 NR has provided data relating to recorded incidents. These relate to miss-use of the crossing but no data has been provided which suggests that there have been any casualties associated with the recorded incidents. The analysis of recorded injury accidents for the area undertaken by Stantec does not provide any clear evidence of accidents directly related to the crossing including driver behaviour associated with the crossing. Indeed, the recent safety record along Sheen Lane is good.
- 3.4.4 Whilst future development in the area will likely increase demand at the Level Crossing whether that is by pedestrians or vehicles, no clear link appears to have been established between the level of demand and accident risk. Whilst it might be expected that increased demand would at least result in an increase in reported incidents, it does not appear to have been borne out based on the fall in incidents reported by BTP during 2016 and 2017 even though the Thomson House School extension, located immediately to the north of the crossing, was by then in place.
- 3.4.5 It is not clear how increased pedestrian demand would in itself increase deliberate misuse of the crossing by pedestrians other than a statistical increase relating to increased numbers. Pedestrian misuse relates to the length of time that the barriers are down and the uncertainty

that barriers create when down for a significant and unknown time leading to some people deciding the risk of crossing after the red light is shown is worth taking. This problem relates more to the frequency of barrier down time rather than to pedestrian demand. The same would apply to drivers' behaviour.

- 3.4.6 Therefore, in terms of any safety implications arising from the Stag regeneration proposals, it is considered that these relate primarily to the sufficiency of the width of the marked footways over the Level Crossing to cater for the existing and proposed demand. The capacity of the existing footbridge is also pertinent since, if this is inadequate, it could deter pedestrians from using the footbridge leading to increased use of the Level Crossing.
- 3.4.7 The following chapter therefore provides an assessment of the likely demand that will be generated by the Stag development proposals and then Chapter 5 provides an adequacy of the footbridge width and the width of the marked footways with and without the Stag development.

## 4 Level Crossing Usage

### 4.1 Overview

- 4.1.1 To understand the potential impact of the Stag Brewery development on the Mortlake Level Crossing, NR requested that Stantec provide an assessment of the likely increased use of the Level Crossing due to the proposed development.
- 4.1.2 The development will increase demand to cross the railway line for the following reasons:
- Increased vehicular demand generated by the Stag development
  - There will be increased demand to access / egress westbound train services from Mortlake Station. This will require use of either the Level Crossing or its associated footbridge
  - Residents cross the rail line in order to access facilities located to the south. This would include primary and secondary schools
  - Increased demand from residents living to the south of the railway line to access new facilities within the development. This would include the secondary school as well as the new retail and leisure facilities proposed within the development.
- 4.1.3 A detailed spreadsheet model has been developed to assess the impact of these additional trips. The trip rates used by this model have been agreed by both LBRuT and TfL as being appropriate for the proposed development. The model provides trip estimates for each use by mode and time of day. Outputs from this model have informed the highway impact and public transport assessments as well as the pedestrian demand analysis.
- 4.1.4 This Chapter provides a summary of the proposed Stag development and the associated trip generation. It then provides a summary of the likely highway impacts so far as they affect traffic using Sheen Lane, based upon the use of the TfL SoLHAM model and assesses the likely additional pedestrian demand to use the Level Crossing, based on a set of first principles assumptions.

### 4.2 Stag Brewery Development Proposals

- 4.2.1 The proposed development at the Stag Brewery site comprises a number of land uses. A breakdown of proposed land uses and their proposed quantum is shown in the following table.

Table 4.1: Stag Brewery Land Uses and Quanta

Land Use	Quanta
Total Residential	Up to 1,250 units
<b>Detailed Application – Application A (Development Area 1)</b>	
Residential	576 Units
Unspecified Flexible Floor Areas inc. Retail / Restaurant / Office / Community / Boathouse	5, 023 sqm
Office	5,532 sqm
Cinema	370 seats

Land Use	Quanta
Hotel	1,765 sqm
<b>Outline Application – Application A (Development Area 2)</b>	
Residential	674 units
<b>Detailed School Application</b>	
Secondary School	Approximately 1,200 pupils

### 4.3 Trip Generation

- 4.3.1 A comprehensive multi-modal trip generation model has been developed for the Stag development proposals. This provides trip numbers by hour for each proposed land use by mode of transport.
- 4.3.2 The spreadsheet model primarily uses data from the Trip Rate Information Computer Systems (TRICS) database but is supplemented by a first principles model relating to the likely use of the cinema. The trip rates have previously been agreed with TfL and LBRuT. The model also takes account of the number of persons taking a westbound and eastbound train from Mortlake station.

### 4.4 Highway Impact Assessment

- 4.4.1 The transport impacts have been updated to reflect revised trip generation figures. These figures have been amended following changes to quantum / development as proposed by the Revised Scheme.
- 4.4.2 The traffic distribution, as part of the original scheme and used in the original TA, was taken from the TfL strategic Highway Assignment Model (HAM). This distribution has also been used for the updated assessment within this TAA. Figures 4.1 and 4.2 show the vehicle trip distribution from the proposed development.
- 4.4.3 The traffic distribution indicates that as a result of the development in the AM peak an additional 34 vehicles will use the crossing northbound and 27 southbound. In the PM peak this is 9 additional northbound trips and 20 southbound trips.
- 4.4.4 It is therefore concluded that from this perspective the additional development vehicle traffic will have no material impact on safety at the Level Crossing.



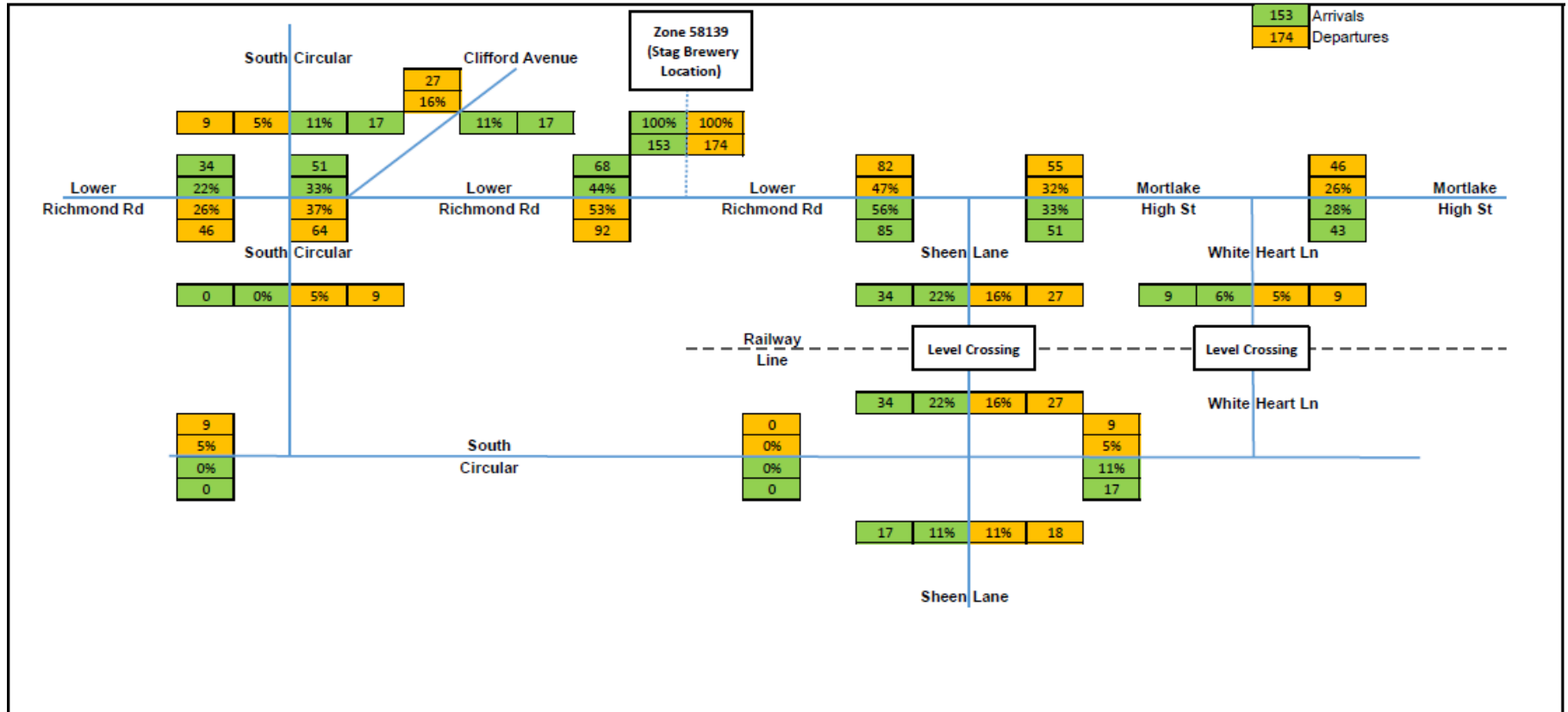

Figure 4-1: AM Peak Development Traffic Distribution

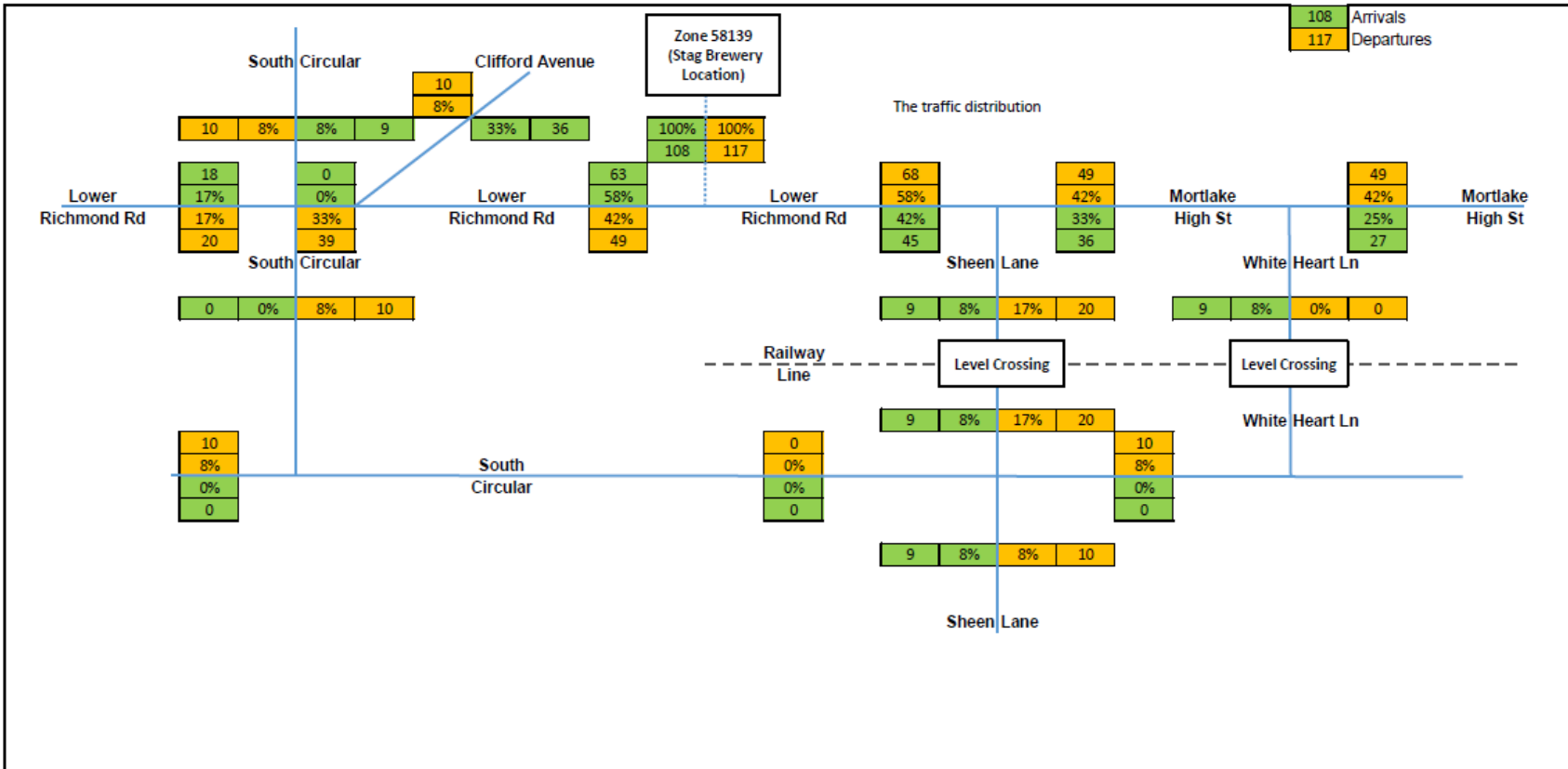

Figure 4-2: PM Peak Development Traffic Distribution

## 4.5 Assessment of Pedestrian Demand

4.5.1 Table 4.2 shows the total pedestrian trip generation for the Stag Brewery development during the morning peak hour. Many of these trips will however be very local and contained within the overall regeneration site, for example trips to the new secondary school and to local shops and other local facilities within the Site. Other trips, for example from Kew and Barnes, will not have to cross the rail line.

Table 4.2: Development Forecast AM Peak Hour Pedestrian and Cycle Trips

Trips	Arrive	Depart	Total
Pedestrian trips	585	378	963
Cycle Trips	39	29	69

4.5.2 It is anticipated that during the AM peak hour the additional demand to cross the rail line as a result of the Stag regeneration will primarily be as a consequence of the following elements:

- Trips to and from the westbound platform of Mortlake Station
- Trips to and from the new secondary school
- Trips from the residential development to local primary schools, primarily the years 5 to 7 of Thomson House School that are located to the south of the rail line
- To a lesser extent trips to the proposed new office and other employment opportunities within the Site.

4.5.3 Not all new pedestrian trips across the rail line will cross at the Level Crossing since there are a number of alternative crossing points. Indeed, for the secondary school, due to its location within the Site, the main desire line will be to use the Kingsway footbridge crossing further to the west.

4.5.4 In addition, the proposed development will also result in trips that currently cross the rail line at the Level Crossing no longer needing to do so. These would be those made by existing residents in properties surrounding the site where existing trips are diverted to the new facilities within the Site. This would include trips to the local shops and other local facilities and the uptake of local job opportunities within the Site. However, the main area of offset would be the reduced need to cross the line to access secondary school places; currently the main local secondary school is the Richmond Park Academy which is located at Park Avenue, approximately a 1,000 metre or 13-minute walk from the Level Crossing.

## 4.6 Trip Distribution

4.6.1 The pedestrian trips were split between trips expected to cross and not to cross the railway line, as outlined below:

### Education (Secondary School) Trips

4.6.2 In order to determine the volume of secondary school pupils that are likely to cross the railway line at Mortlake the following methodology has been adopted:

- LBRuT provided catchment areas of primary schools in the local area that will function as feeder schools for the proposed secondary school at the Site. Based on the primary schools' capacity and the population in the catchment area it has been calculated that 41% live to the north of the railway line and 59% to the south
- Each school's catchment area south of the railway line was divided into portions of residents that would cross the rail line at Mortlake

- Based on a proposed school capacity of approximately 1260, this would result in 21 pupils crossing the railway line at Mortlake in a northbound direction in the morning peak hour.

**Education (Primary School) Trips**

4.6.3 The socio-economics assessment undertaken for the proposed development suggests the development will accommodate the following mix of children:

- 150 early year children, and
- 110 primary school age children.

4.6.4 To establish the volume of primary school children that are likely to cross the rail line at Mortlake, the following methodology has been applied:

- It is assumed that the primary school pupils from the development will attend one of the three closest primary schools: Kew Riverside Primary, Thomson House or Barnes Primary. Based on their capacities, primary school children from the proposed development site have been distributed to each school
- Thomson House school teaches its pupils in Year 5 to 7 in a building south of the railway line whereas all the other schools are located north of the railway. Based on the school’s capacity, it is assumed that 19% of the 260 primary school children would attend Thomson House school (years 5 to 7), which equates to 49 pupils crossing the railway line at Mortlake in the morning peak hour, travelling southbound
- As it is deemed unlikely that children would walk alone, as a worst-case scenario it has been assumed that each child would be accompanied by an adult, who would walk back to the development after dropping off the pupil

4.6.5 Based on the above, it is likely that 98 trips would be made in the morning peak hour across the railway line at Mortlake in a southbound direction. In this it has been assumed that adults would return to the development after the morning peak hour, thus these trips have not been taken account of within the detailed analysis.

**Rail Trips**

4.6.6 In addition to the education, there will be those made to and from Mortlake station on foot. The trip generation model prepared for the development also takes account of the number of persons taking a westbound and eastbound train from Mortlake station.

4.6.7 Only trips to and from the westbound platform at Mortlake station would require crossing the rail line at Mortlake. These rail trips are shown in the following table. It is considered that, since the majority of people will be seeking to catch a specific train, and therefore not wishing to be delayed by the crossing barriers, the majority of these people will use the footbridge to access the westbound platform.

Table 4.3: Development Forecast AM Peak Hour Rail Trips to Mortlake Westbound Platform

Trips	Arrive	Depart	Total
Rail trips to Mortlake station westbound platform	121	34	155

**Bus Trips**

4.6.8 There is expected to be a minimal demand from persons walking over the Level Crossing and footbridge to reach the bus stops on the South Circular Road. This is due to:

- Good provision of buses along Lower Richmond Road immediately outside the development and along Clifford Avenue. These bus routes (the 419, N22 and 209) run west to Richmond and east to Barnes which is parallel to the routes provided on the South Circular by the 337, 33, 337 and 493 buses

- The distance to walk to the bus stops on the South Circular is 750m or an approximately 9.5-minute walk from the Site which acts as a disincentive
- There are more convenient alternative options to these routes for most journeys i.e. the rail service from Mortlake or one of the closer bus services

4.6.9 Therefore, no walking trips to bus stops have been included in the assessment.

### Remaining Trip Types

#### Overview

4.6.10 The remaining pedestrian trips are categorised as either: residential, retail, hotel, office, cinema, gym and community, or extra care and healthcare trips. Each of these trip types' pedestrian trips are split between journeys to destinations north and south of the railway line. The methodology for splitting each trip types of journeys is explained below.

4.6.11 Those trips on foot to destinations south of the railway line have then been split proportionally between crossing points, except where explained otherwise, according to the catchment area of each zone south of the railway line that is within a 1.0 km radius or a 12.5 m walk from the Stag Brewery as shown in Figure 4.3 below.

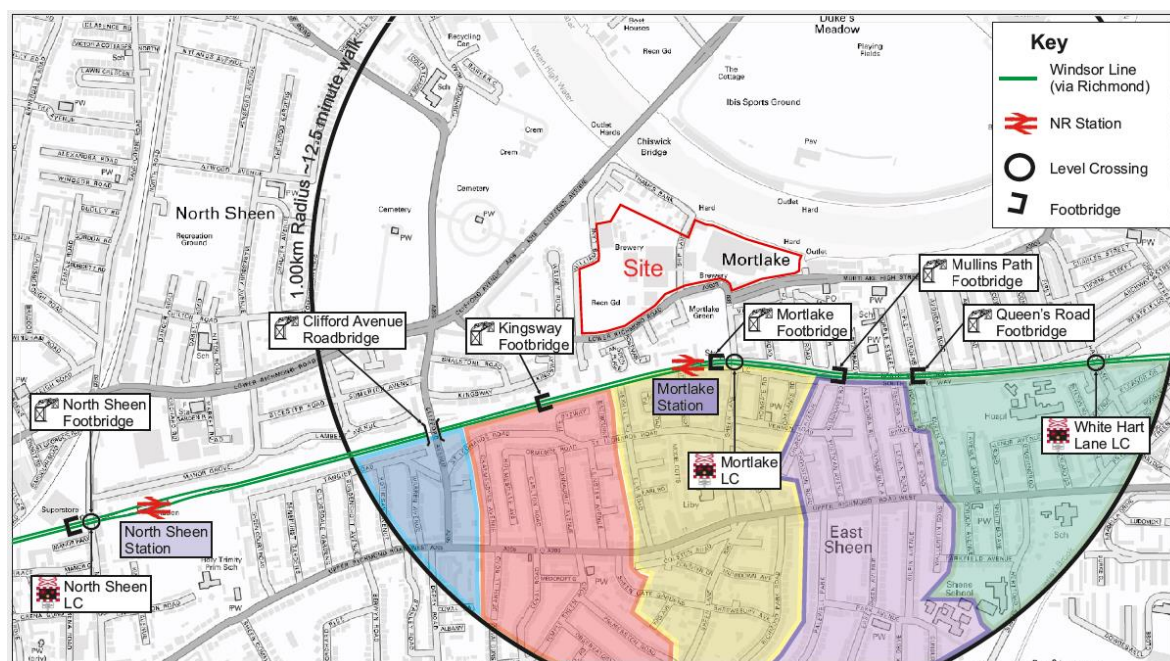

Figure 4.3: Catchment areas (south of the railway) for each crossing

#### Residential Trips

4.6.12 The trip generation analysis shows that the residential development will generate 214 two-way walking trips during the AM peak hour. Given the number of school-age children likely to be living on site, it has been assumed that the vast majority of residential walking trips in the morning peak hour are associated with educational and educational escort trips, which have been covered above.

4.6.13 It is also assumed that the remaining pedestrian trips generated by the residential development during the morning peak hour would most likely be very local trips, either internal to the site or to areas immediately surrounding the Site. This includes persons walking along the river embankment and north towards Chiswick and the amenities around the Site. As such, 90% of trips will be to/from destinations north of the railway line. The remaining trips go south of the railway line and are split proportionally between the crossings as explained in 4.6.11.



#### *Retail Trips*

- 4.6.14 The retail trips to the Site are expected to be highly localised and as such there would be a very small number of persons visiting the Site's retail shops who originate from south of the railway line and need to cross the railway line to reach the Stag Brewery site. In fact, there is already a convenience store (Tesco Express) and a wide array of other retail shops located just south of the Level Crossing making it unlikely visitors to the Site's retail stores would walk from the south of the railway line during the morning peak hour.
- 4.6.15 Therefore, the impact of this use on the Level Crossing is considered to be insignificant and is likely to be outweighed by existing trips that do cross the railway line from the north being diverted to the Stag. As such, 93% of trips will be to/from destinations north of the railway line. The remaining trips go south of the railway line and are split proportionally between the crossings as explained in 4.6.11.

#### *Hotel Trips*

- 4.6.16 The pedestrian trips related to the proposed hotel development on site are also likely to be very localised but as tourists and visitors would be unfamiliar with the local area, they are likely to follow Sheen Lane to the Mortlake Level Crossing and cross the railway line at that point. This also follows the natural desire line to the main section of shops and restaurants in the area.
- 4.6.17 The trip generation exercise for the proposed development has forecast that the proposed hotel would generate just one additional pedestrian trip during the morning peak hour. Of the trips generated 50% are to/from destinations north of the railway line. The remaining trips go south of the railway line and are split proportionally between the crossings as explained in 4.6.11 which yields zero trips across the Mortlake crossing.

#### *Office Trips*

- 4.6.18 The trip generation assessment undertaken for the proposed office on site has forecast that a total of 18 two-way morning peak hour trips would be undertaken by foot.
- 4.6.19 The office trips on foot would mainly be composed of office workers who live within the walking catchment area walking to work in the peak hours. Although it is considered likely that some of the forecast walking trips would be site internal as residents of the proposed development could also work on site. Of the trips generated 50% are to/from destinations north of the railway line with the remainder split proportionally between the crossings as explained in 4.6.11.

#### *Cinema Trips*

- 4.6.20 The proposed cinema is not anticipated to generate any walking trips in the AM peak hour as it is unlikely to be open at this point of the day.

### **4.7 Trip Summary at Level Crossing**

- 4.7.1 Table 4.4 summarises the likely pedestrian trips across Mortlake Level Crossing and footbridge in the morning peak hour generated by the proposed development on the Stag Brewery site. The split between the at-grade Level Crossing and footbridge is based on the proportions observed in the video footage for persons making through-trips and those accessing a station platform respectively. An exception to this for persons departing the development in order to join a train from the westbound platform - these journeys are time critical, so all these persons are assumed to use the footbridge rather than waiting at the Level Crossing.

Table 4.4: Development Walking Trips at Level Crossing and Footbridge (AM peak hour)

Trips Land Use	Southbound		Northbound	
	Level Crossing	Footbridge	Level Crossing	Footbridge
Residential	2	2	1	1
Educational (Secondary School)	2	2	21	21
Educational (Primary School)	15	15	0	0
Retail	2	2	2	2
Hotel	0	0	0	0
Office	0	0	1	1
Rail	0	38	24	5
<b>Total</b>	<b>21</b>	<b>59</b>	<b>49</b>	<b>30</b>
	<b>80</b>		<b>79</b>	

*\*Note: discrepancy in total due to rounding error*

## 5 Impact Assessment

### 5.1 Overview

- 5.1.1 This chapter reviews of the likely impact of the Stag development proposals on the Mortlake level crossing based on the trip estimates set out in Chapter 4.
- 5.1.2 It is noted in the previous chapter that, based on the highway modelling undertaken using the TfL strategic modelling, the proposed development should have no material impact on traffic flow or journey times for traffic travelling across the level crossing. Therefore, this impact assessment has focussed on two main aspects:
- Does the existing footbridge provide sufficient capacity to accommodate the additional demand that will be generated, both by through pedestrian movements along Sheen Lane but also taking account of the increased demand to use the footbridge to access the station platforms; and
  - Will the footways, including the marked pedestrian crossing areas within the level crossing, have sufficient capacity to accommodate pedestrian demand.
- 5.1.3 This assessment is carried out at the request of NR. As discussed previously, it is far from clear that there is any direct link between pedestrian demand to use the crossing and safety.

### 5.2 Pedestrian Demand Flows

- 5.2.1 Table 4.4 shows the anticipated additional pedestrian flows due to the development at the Mortlake crossing based on the trip assessment undertaken within Chapter 4.

### 5.3 Review of Bridge and Staircase Capacity

- 5.3.1 NR's '*Station Capacity Planning Guidance*' (November 2016) has been used to assess conditions at Mortlake footbridge including the staircases with the proposed development at the Stag Brewery fully occupied, as the guidance

*"includes all calculations required to assess whether a station meets Network Rail's aspirations regarding passenger comfort and safety in the station environment..."* and

*"provides a good practice guide for undertaking capacity assessments".*

- 5.3.2 Section 3.6.1 of the Guidance provides the following equation to calculate the notional minimum width of a two-way passageway based on NR's requirement for a Fruin Level of Service (LoS) C. The average peak minute flow is increased by 25% in order to take account of possible service delays that may lead to fluctuations in passenger flow through the station.

$$\text{Notional Two-way width (m)} = \frac{\text{Average Peak Minute Flow}}{40} + (2 \times 0.3)$$

- 5.3.3 The notational width for the baseline and future baseline with proposed development scenarios is shown in Table 5.1. The guidance recommends a minimum passageway width of 1.9m on either side of a central division (1.6m passageway plus 0.3m edge effect) plus the width of the central divider (0.05m), given a minimum required width of 3.85m unless the notational width is greater than this. Note that in the calculations in this section the number of cyclists using the footbridge and staircase are included in the average peak minute flows.

Table 5.1: Notional and Required Width of Mortlake Footbridge

Scenario	Average Peak Flow (people/ min)	Notional Two-Way Width (m)	Required Width (m)
Baseline	19.32	1.204	3.85
Baseline with Proposed Development	22.13	1.292	3.85

5.3.4 As can be seen, the notional two-way width increases by 0.088m in the baseline plus proposed development scenario compared to the baseline scenario. Comparing the notional width and required width for both assessed scenarios, it can be seen that in both scenarios sufficient spare capacity is available to accommodate the notional demands.

5.3.5 As shown in Chapter 2, the existing footbridge width is 4.0m wide and such, sufficient width is provided to accommodate the baseline and the proposed development’s demand in the future.

## 5.4 Mortlake Staircase

5.4.1 Section 3.6.3 of NR’s Guidance provides the following equation to calculate the notional minimum width of a two-way staircase for the footbridge based on NR’s requirement for a Fruin LoS C.

$$Two - way\ staircase\ width\ (m) = \frac{Average\ Peak\ Minute\ Flow}{28}$$

5.4.2 The notational width for the baseline and future baseline with proposed development scenarios is shown in Table 5.2. The guidance recommends a minimum staircase width of 1.6m between handrails, unless the notational width is greater than this.

Table 5.2: Notional and Required Width of Mortlake External Staircase

Scenario	Average Peak Flow (people/ min)	Notional Two-Way Width (m)	Required Width (m)
Baseline	15.40	1.288	1.6
Baseline with Proposed Development	18.22	1.413	1.6

5.4.3 As can be seen, the notional two-way width increases by 0.125m in the baseline plus proposed development scenario compared to the baseline scenario. Comparing the notional width and required width for both assessed scenarios, it can be seen that in both scenarios sufficient spare capacity is available to accommodate the notional demands.

5.4.4 As shown in Chapter 2, the existing staircase width is 2.0m wide. As such, sufficient width is provided to accommodate the baseline and the proposed development’s demand in the future.

## 5.5 Review of Mortlake Level Crossing

- 5.5.1 As NR’s ‘Station Capacity Planning Guidance’ does not include guidance for flows across Level Crossings, the Office of Rail Regulation’s (ORRs) ‘*Level Crossings: A guide for managers, designers and operators*’ (December 2011) has been used instead as it provides a section on pedestrian using Level Crossings. This categorises Level Crossings depending on their usage into one of three class: A, B or C. The class of Level Crossing dictates the minimum width of the footway required.
- 5.5.2 To calculate the class, Section 2.185 of the guidance requires the Train Pedestrian Value (TPV) to be calculated as the product of the maximum number of pedestrians crossing the Level Crossing in a 15-minute period and 25% of the number of trains passing over the crossing in the same hour.
- 5.5.3 The guidance stipulates that the maximum number of pedestrians using the crossing in a 15-minute period should be 75% of the maximum hourly figure if the number of pedestrians is estimated rather than surveyed.
- 5.5.4 The following equation has been used to calculate the TPV value for the baseline and baseline plus proposed development scenarios:

$$\text{Train Pedestrian Value} = 75\% \text{ of hourly Pedestrian Flow} \times 25\% \text{ of hourly Trains}$$

- 5.5.5 As outlined in Chapter 2, currently 12 trains per hour pass through Mortlake Level Crossing. The following table shows TPVs for the baseline and baseline with development scenarios based on 12 trains per hour.

Table 5.3: Train Pedestrian Values during the AM Peak Hour

Scenario	75% of Hourly Flow	Trains in 15-Minute Period (based on 12 trains/ hr)	TPV
Baseline	142	3	425
Baseline with Proposed Development	198	3	595

- 5.5.6 Based on the above TPVs, the Level Crossing can be categorised into class A, B or C, which are defined as follows:

Table 5.4: ORR’s Pedestrian Categories for Level Crossing

Pedestrian Category	TPV
A	More than 450
B	151 – 450
C	150 or less



5.5.7 The following table shows the category based on the calculated TPVs.

Table 5.5: Mortlake Level Crossing TPVs and associated Categories

Scenario	TPV	Category	Required Minimum Width
Baseline	425	B	1.8m
Baseline with Proposed Development	595	A	2.0m

5.5.8 As outlined in Chapter 2, the footways across Mortlake Level Crossing measure approximately 1.6m in width on each side of the carriageway.

5.5.9 Although not mentioned in the ORR guidance, it is considered that as the TPVs are based on two-directional flows, both footway widths would need to be added together to realistically assess the footway width required for the baseline plus proposed development scenario. Based on this consideration, the existing footway width across Mortlake Level Crossing is approximately 3.2m.

5.5.10 Table 5.5 shows that in the baseline scenario, a minimum footway width of 1.8m is required, while in the baseline plus development scenario a minimum footway width of 2.0m is required. As 3.2m footway width is currently provided, it is considered that the existing footways across Mortlake Level Crossing have sufficient spare capacity to accommodate the additional demand generated by the proposed development at the Stag Brewery development.

## 5.6 Summary

5.6.1 The assessment of future pedestrian demand for both the footbridge and the Level Crossing suggests that the current infrastructure meets required standards both now and in the future.

## 6 Options for Improving Safety

### 6.1 Overview

6.1.1 This chapter sets out the existing safety measures that are in place at the Level Crossing and then lists the various options that have been identified as a possible means for further improving safety at the crossing. NR's views on these various options is highlighted and a potential strategy for improving safety is described.

### 6.2 Existing Safety Conditions

6.2.1 The Level Crossing benefits from the following safety equipment:

- CCTV monitoring by signaller
- Full barrier equipment
- Road traffic light signals
- Audible alarm
- Signage (including instructions for pedestrians to use the footbridge), and
- Train signalling protection.

6.2.2 In addition, the crossing is complimented with a footbridge, which provides an alternative through route for the majority of pedestrians to use and so removing the need to wait at the barriers when they are down.

6.2.3 As such, NR considers that the Level Crossing currently has the highest level of safety protection. Based on this it has also stated that, in its view, safety risks at this location primarily relate to potential vehicle/pedestrian conflicts since risks to trains and therefore passengers are effectively managed by the current safety equipment and remote manual control of the crossing. On this basis NR has stated that it is therefore unable to justify any further spending on improving the Level Crossing or its associated infrastructure.

6.2.4 In their Risk Assessment, NR reviewed potential options for improving the safety of the crossing as follows:

- I. **Complete closure of the Level Crossing with potential replacement by a footbridge and/or for road bridge/tunnel.** This is in line with their policy to reduce the number of Level Crossings and so is their preferred option. However, it concluded that closure of the crossing to vehicular traffic was unlikely to be feasible and could not in any case be justified in cost benefit terms
- II. **Provision of red light enforcement cameras with automatic number plate recognition** as recently installed at the nearby White Hart Crossing. The report concluded that such a system would not address the main safety issues here i.e. pedestrian/ vehicle conflict, and deliberate pedestrian/ vehicle misuse and was again ruled out on cost benefit grounds
- III. **Renewal of the Crossing**, or increasing the width to allow provision of wider marker pedestrian areas across. This was also ruled out on the basis that there would be no quantifiable reduction in risk benefit.

6.2.5 The assessment also briefly considers the potential benefits of providing a new/ improved footbridge and concludes "The concern (pedestrian/ vehicle conflict) arises despite the presence of a suitable bridge at Mortlake something which is not available at its neighbouring crossing White Hart Lane and, which experiences similar issues. It is unlikely that another bridge structure at the site would solve this problem.

- 6.2.6 At the meeting with Mr Goldsmith, MP a number of options were identified as worthy of proper consideration as follows:
- IV. Improved signing of the footbridge
  - V. Signage to urge drivers to turn off engines when waiting for the barriers
  - VI. Provision of a count-down clock so that pedestrians were better informed about likely wait times
  - VII. Further improvements to the pedestrian bridge, and
  - VIII. Comprehensive traffic management measures aimed at slowing traffic and providing greater priority for pedestrians and cycles.
- 6.2.7 The meeting agreed that further investigation should be undertaken regarding the possibilities for renewing the crossing, to provide wider marked footways and to look at provision of camera enforcement.
- 6.2.8 The above strategy was endorsed by the LBRuT.
- 6.2.9 The meeting also concluded that the closure of the Level Crossing was not feasible for a number of reasons, including impact on other crossings, feasibility for providing either an alternative bridge/ tunnel on cost/ environmental grounds. This was also agreed by the LBRuT.
- 6.2.10 The response letter from NR has discounted the use of countdown times as being impractical and whilst it states that improved signing and road and footway markings will be considered further it surprisingly (in view of the stance taken in the Risk Assessment) suggests that there is a need to provide a new ramped footbridge at the site. No justification is provided for this nor does the feasibility for providing such a structure appear to have been considered.

### 6.3 Discussion

- 6.3.1 Whilst NR appears to have concern regarding the level of misuse at the crossing i.e. attempting to cross by both traffic and pedestrians after the red lights start flashing, which appears to be the main contributory factor to the high safety risk score for the site this appears to be at odds with NR's apparent conclusion that the current safety measures at the site provide adequate protection of trains and passengers and that the main risks relating in part to improper use.
- 6.3.2 There is no clear picture regarding the real safety risks at this location from the analysis that has so far been provided by NR. The main risk that they have identified relates to pedestrian/ vehicle conflicts.
- 6.3.3 The collision data from 2011 – 2020 does not show any pattern of injury accidents relating to the Level Crossing.
- 6.3.4 In relation to the potential impacts of the proposed Stag development on safety factors at this site then:
- The traffic analysis undertaken as part of the initial TA and subsequent TAA suggests that with the proposed Chalkers Corner improvements which form a key element of the proposals there will be no material impact on traffic flows or delays for traffic travelling across the crossing
  - There will be some increase in existing pedestrian demand at the site both from pedestrians travelling along Sheen Lane, mainly associated with accessing years 4 to 7 at

Thomson House School and for passengers accessing and egressing the westbound platform at the station

- The assessment of pedestrian flows suggest that the current footbridge and stairways provide sufficient capacity to meet both current and future demand with the Stag
- The assessment of pedestrian flows also suggests that the width of the marked footway areas on the Level Crossing also meet required standards both now and in the future with the Stag.

6.3.5 Based on the above, it is considered that the proposed development would not have a severe impact upon the Level Crossing and associated infrastructure.

## 6.4 Potential Strategy

6.4.1 Notwithstanding the above conclusion, it is considered that there is merit in improving conditions, in particular for pedestrians and cycles in and around the station and the crossing. It is considered that the following measures should be considered further:

- Potential for improving the pedestrian access to the station from the north over the builder's merchants yard – it is not clear whether NR has any control over this land
- Whilst the width of the marked footways over the crossing appear to meet the required standards it is considered that there would be merit in widening these areas. It is not clear what this would entail in design terms and cost and so it is considered that NR should take the lead in providing detailed study
- Associated with the above, the feasibility for improving road markings, including the possible use of surfaced treatment at the crossing should be investigated
- There appears to be limited scope to provide a new footbridge or to enhance the current one (potentially with the additional of lifts to cater for buggies and those with impaired mobility). Detailed land ownership information would be required from NR to allow this to be considered further
- Provision of red light enforcement cameras would appear to address one of the main concerns identified by the NR Risk Assessment
- Whilst there is no record of injury accidents along Sheen Lane, the developer has proposed a 20 mph zone along the site frontage and extending down Sheen Lane towards the crossing as part of its proposals. This is in line with the Stag Planning Brief and would appear to be in line with current Mayer's policy to promote "Healthy Streets". It is considered that this would further enhance safety around the Level Crossing
- It is understood that Thomson House School, as part of its travel planning has included initiatives to promote the proper use of the crossing. These initiatives could be extended to the proposed new secondary school and to the rest of the development. Ultimately, the secondary school could seek to enforce a ban on children using the Level Crossing instead requiring the use of the footbridge or other bridges in the area.

## 7 Summary and Conclusion

### 7.1 Summary

- 7.1.1 This Note has been prepared to address safety concerns raised by Network Rail (NR) relating to increased usage of the Mortlake Level Crossing as a result of the proposed Stag Brewery development. Specifically it responds to the concerns raised in NR's 'Mortlake Level Crossing Risk Assessment' (July 2017) and NR's letter to Zac Goldsmith MP (26 October 2017), by discussing the likely impact of the increased pedestrian and vehicle demand to be generated by the Stag Brewery development on Mortlake station Level Crossing.
- 7.1.2 The crossing is located on Sheen Lane. Immediately to the west of the crossing is Mortlake station which lies on the Windsor Lines (via Richmond). Eight trains per hour call and an additional 4 trains per hour pass through the Level Crossing during a typical daytime hour. Mortlake station includes a footbridge which provides an alternate route for pedestrians to cross the railway line when the barriers at the crossing are down as well as access to the platforms.
- 7.1.3 The existing crossing has marked out footways on both sides, which are approximately 1.6m wide each. The footbridge, which has a width of 4.0m, is accessed via two sets of staircases, which are each 2.0m width.
- 7.1.4 NR requested that Stantec, on behalf of the Stag Developer, assess the likely impact of the proposed development on the Level Crossing and associated footway. The assessment, which has been summarised in this report, has focussed on the AM peak, since this is considered to provide a worst case since at that time there are heavy pedestrian demand associated with both commuters and trips to school. Surveys were undertaken in June 2016 and again in June 2017, to establish both vehicular and pedestrian use of the infrastructure. respectively.
- 7.1.5 NR's risk assessment of the crossing suggests that the trains and passengers are adequately protected by the existing safety features at the crossing. It intimates that the main risk relates to potential vehicle/ pedestrian conflict at the crossing. This in turn appears to be related to the long wait time due to the barriers being down between 40 and 45 minutes in any hour.
- 7.1.6 The Risk Assessment provides no clear analysis of risk nor does it recommend any specific improvements, other than a preference for complete closure of the Level Crossing, but which it acknowledges is unlikely to be feasible. It states that, since there is an existing bridge, a new or improved footbridge is unlikely to resolve their safety concerns.
- 7.1.7 There appears to be no clear evidence that the conflict between pedestrians and traffic referred to in the Risk Assessment occurs in practice. A review of collision data suggests that Sheen Lane has a good safety record with no pattern of accidents associated with the crossing.
- 7.1.8 In relation to the potential impacts of the proposed Stag development on safety factors at this site then:
- The traffic analysis undertaken as part of the wider TA suggests that with the proposed Chalkers Corner improvements which form a key element of the proposals there will be only a small impact on traffic flows or delays for traffic travelling across the crossing
  - There will be some increase in existing pedestrian demand at the site both from pedestrians travelling along Sheen Lane, mainly associated with accessing years 4 to 7 at Thomson House School and for passengers accessing and egressing the westbound platform at the station



- The assessment of pedestrian flows suggest that the current footbridge and stairways provide sufficient capacity to meet both current and future demand with the Stag
- The assessment of pedestrian flows also suggests that the width of the marked footway areas on the Level Crossing also meet required standards both now and in the future with the Stag.

7.1.9 Based on the above, it is considered that the proposed development would not have a significant impact upon the operation and safety of the Level Crossing and associated infrastructure.

7.1.10 Notwithstanding the above conclusion, it is considered that there is merit in improving conditions, in particular for pedestrians and cycles in and around the station and the crossing. It is considered that the following measures should be considered further:

- Potential for improving the pedestrian access to the station from the north over the builder's merchants yard – it is understood that NR own the freehold to this land but the terms of the lease are unknown
- Whilst the width of the marked footways over the crossing appear to meet the required standards it is considered that there would be merit in widening these areas. It is not clear what this would entail in design terms and cost and so it is considered that NR should take the lead in providing detailed study
- Associated with the above, the feasibility for improving road markings, including the possible use of surfaced treatment at the crossing should be investigated
- There appears to be limited scope to provide a new footbridge or to enhance the current one (potentially with the additional of lifts to cater better for buggies and the disabled). Detailed land ownership information would be required from NR to allow this to be considered further
- Provision of red light enforcement cameras would appear to address one of the main concerns identified by the NR Risk Assessment
- Whilst there is no record of injury accidents along Sheen Lane, the developer has proposed a 20 mph zone along the site frontage and extending down Sheen Lane towards the crossing as part of its proposals. This is in line with the Stag Planning Brief and would appear to be in line with current Mayer's policy to promote "Healthy Streets". It is considered that this would further enhance safety around the Level Crossing, and
- It is understood that Thomson House School, as part of its travel planning has included initiatives to promote the proper use of the crossing. These initiatives could be extended to the proposed new secondary school and to the rest of the development. Ultimately, the secondary school could seek to enforce a ban on children using the Level Crossing instead requiring the use of the footbridge or other bridges in the area.

## Appendix A NR Risk Assessment (July 2017)



# Mortlake Level Crossing Risk Assessment



Date assessment compiled 26<sup>th</sup> July 2017

## **CONTENTS**

### **1. INTRODUCTION**

1.1 Background

### **2. DESCRIPTION OF THE SITE**

2.1 Current Level Crossing details

2.2 Environment

2.3 Crossing Usage

2.4 Rail Service

2.5 Future developments

2.6 Incident history

2.8 Vegetation Risk

2.8 ALCRM (All Level Crossing Risk Model) Scores

### **3. BARRIER DOWN TIME ANALYSIS**

### **4. OPTION ASSESSMENT**

4.1 Closure via diversion or road- rail Bridge

4.2 Red Light Enforcement Cameras (RLSE)

4.3 Renewal of crossing (partial/full)

### **5. COST BENEFIT ANALYSIS**

### **6. CONCLUSION**

## 1. INTRODUCTION

This document provides the necessary supporting safety information to a decision making process for Mortlake Level Crossing, leading to recommendations as to the most suitable level crossing option that reduces the risk to as low as is reasonably practicable.

### 1.1 Background

Mortlake level crossing is located on the Reading to London Waterloo line. It is an urban Manually Controlled Barrier CCTV crossing with a 4 barrier layout situated near a major arterial road connecting Barnes to Upper/Lower Richmond and has multiple approach roads. The line speed is 60mph in directions, slowing and accelerating for Mortlake Station which is immediately adjacent to the crossing.

Road space is restricted on the main approach road Sheen Lane which has a speed limit of 30 mph. There are footpaths on each side of the road, each of them being narrower over the crossing than on the pedestrian approaches. There is a footbridge at the station which allows for pedestrian access and standard signage is provided on each approach.

## 2. DESCRIPTION OF THE SITE

### 2.1 Current Level Crossing Details

<b>Level Crossing Name</b>	<b>Mortlake</b>
Level Crossing Type	CCTV-MCB
Engineers Line Reference (ELR)	RDG1
Mileage	8 miles 21 chains
OS Grid Reference	TQ205758
Local Authority	Richmond Borough Council
Supervising Signalbox	Wimbledon
Number of running lines	2
Maximum Permissible Line Speed	60mph



## 2.2 Environment

### Aerial map and Ordnance survey of the location

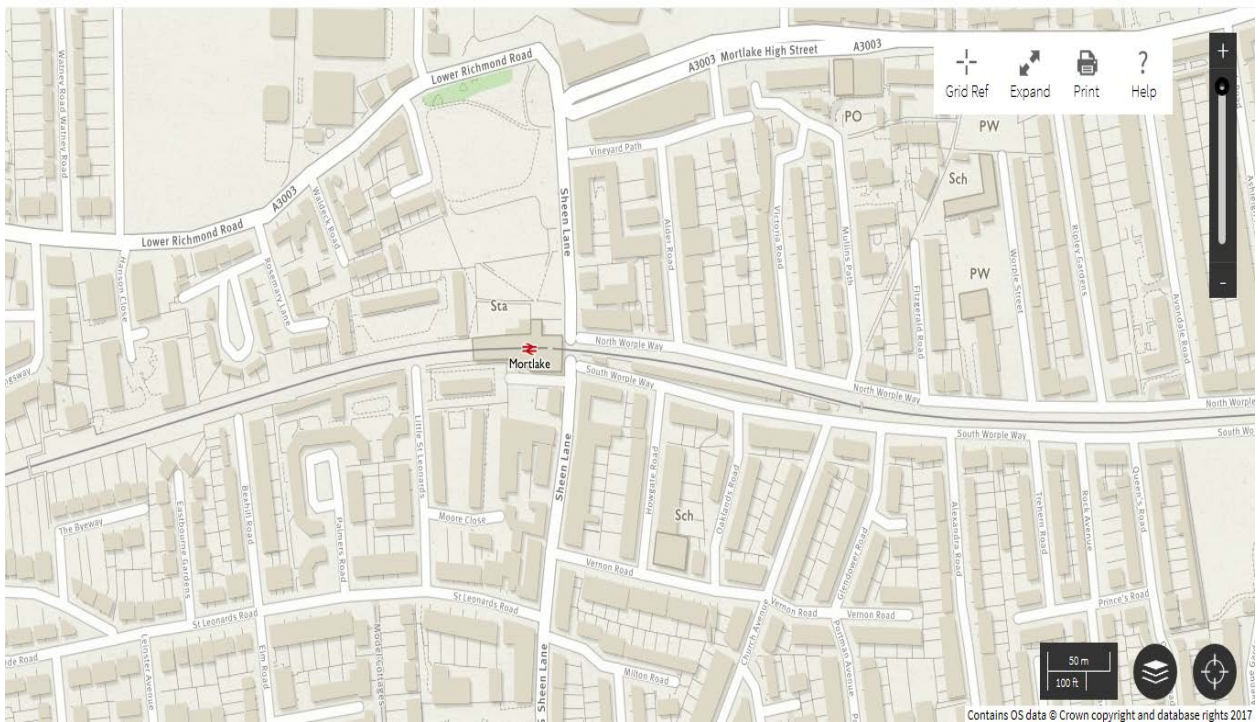
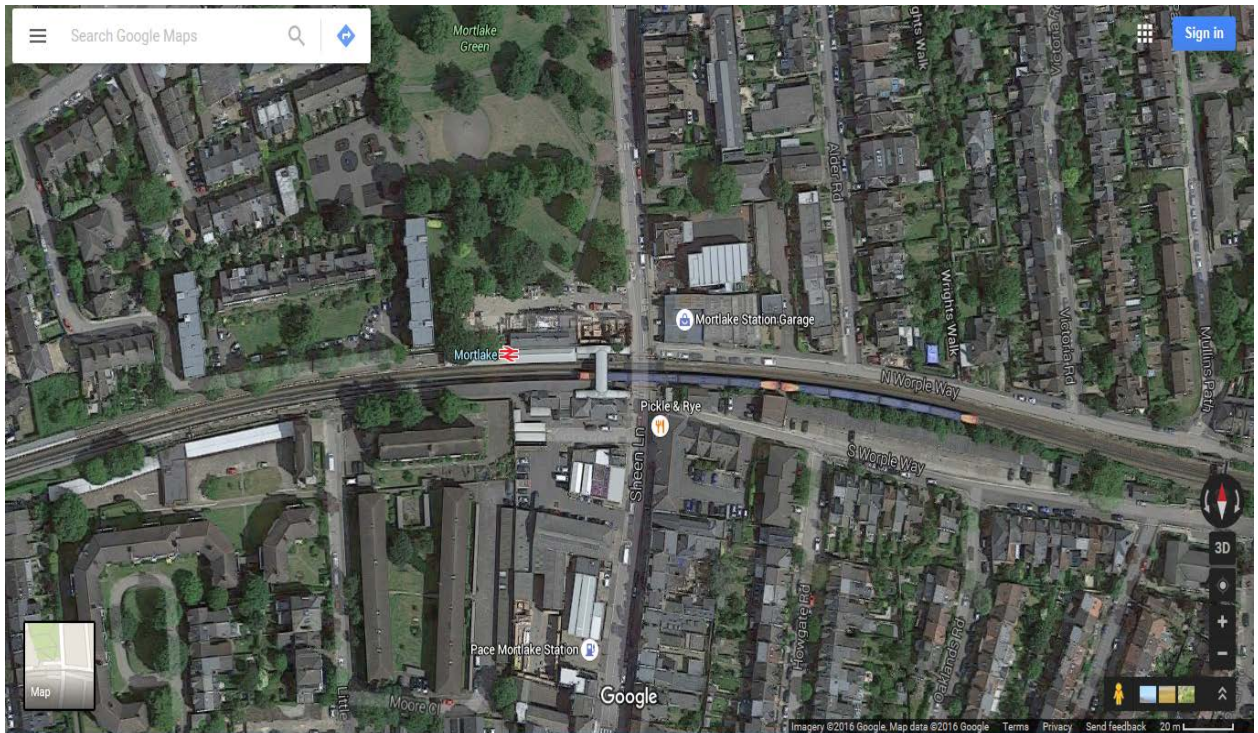

## Sectional appendix extract of the crossing

LOR	Seq.	Line of Route Description	ELR	Route	Last Updated		
SW210	003	Clapham Junction to Reading	RDG1	Wessex	30/11/2015		
Location		Mileage M Ch	Running lines & speed restrictions		Signalling & Remarks		
White Hart LC (CCTV)		7 52			TCB RA8	Wimbledon SB (W) DC: Raynes Park	GSM-R 
Mortlake LC (CCTV)		8 21					
<b>MORTLAKE</b>		8 21					
<b>NORTH SHEEN</b>		9 03					
North Sheen LC (CCTV)		9 12					
		9 50 *					
<b>RICHMOND</b>		9 57					
					Feltham SB (F)		

## Down line approach to the crossing



### 2.3 Crossing Usage

A quick census was conducted on 5<sup>th</sup> October 2016 by the Level Crossing Manager at 10:40hrs for a period of 30 minutes. The census applies to 100% of the year. The findings were as follows:

<b>Cars</b>	122
<b>Vans / small lorries</b>	16
<b>Buses</b>	0
<b>HGVs</b>	6
<b>Pedal / motor cyclists</b>	28
<b>Pedestrians</b>	60
<b>Tractors / farm vehicles</b>	0
<b>Horses / riders</b>	0
<b>Animals on the hoof</b>	0

Available information indicates that the crossing does have a high proportion of vulnerable users for a crossing of its type and location. When the census data is aggregated within the ALCRM (All Level Crossing Risk Model) algorithms, it realises a daily usage of 3,888 vehicles users and 2,376 pedestrian and cycle users per day.

### 2.4 Rail Usage

Rail traffic is heavy at the location with a combination of both passenger and freight services. Most services use Class 458 and class 450 rolling stocks with occasional use of EMU (Electric Multiple Unit). There are 349 trains per day that run over this crossing.

There are currently no known plans to increase train services in the area, although franchise commitments will mean some potential increase in the next few years.

### 2.5 Future developments

The Stag brewery site near the neighbouring Mortlake level crossing is currently due for development and an application is likely to be submitted in September/October 2017. Similarly there were also historical proposals for the Barnes Hospital / adjoining site for the facilitation of a school or, a residential mixed-use development.

Network Rail is a statutory consultee for all of the main crossings in Richmond and is continually in contact with Richmond Borough Council and associated stakeholders. This would include the potential for the introduction of risk to all of these level crossings by virtue of these developments and on each merits is required to consider possible contributions either under Section 106 or Community Infrastructure Levy intentions to mitigate such risk.

This holistic approach to all the crossings in the Richmond area is imperative and requires the conjoined review by the Wessex Level Crossing Team, the Wessex Capacity/Performance team and Richmond Borough Council/Richmond Highways. At the time of writing, indications are that the Stag Brewery site appears to be a substantive proposal although the impact of that remains notional at this stage. It is probable that this has the potential to increase the risk and usage at Mortlake crossing (further explained



below in section 2.6) and resulting mitigations proposed to negate this could, effectively dissipate the risk to the other crossings in the area therefore, a meeting is being scheduled for a high level review in August 2017.

## 2.6 Incident history (Source SMIS)

Date	Short Description
18 Feb 17	Lorry struck and ripped off the down side facing barrier at Mortlake LX
27 Jan 17	A flatbed lorry had struck the up facing boom at Mortlake LX
20 Oct 16	Pedestrian ran across LX after the barriers had been lowered
23 Sep 16	A lorry had struck the down side facing barrier at Mortlake LX knocking off the barrier
22 Aug 16	MOP crossed as the barriers were lowering at Mortlake LX
16 Jul 16	Male and female crossed Mortlake LX after leading booms had lowered
16 Jul 16	Cyclist crossed with road lights flashing at Mortlake LX

Mortlake Level Crossing scores high on both individual and collective risk with it being the 4<sup>th</sup> riskiest CCTV crossing on the Wessex Route. This means that the risks to pedestrians or, road users are high and also that the risks to passengers on trains are high. However, the majority of the risk is controlled by the full barriers separating road users from the trains and the signaller protecting the crossing ensuring that a train cannot approach unless the crossing is clear.

Above is a snap-shot extract of deliberate misuse at the crossing within the past year. Deliberate misuse is prolific and almost occurs on a daily basis which is similar to other crossings in the area or, comparable CCTV crossings situated in congested urban environments. Historic data shows not only that the deliberate misuse is sustained over a number of years, but that this has resulted in other incidents such as regular near-miss events (1-2 per year for the last ten years although less in the last few years) and barriers strikes where vehicles have managed to knock barriers off completely (2-3 per year for the last ten years)

The barrier downtime at the crossing (see section 3) is lengthy and thus is likely to be a contributory factor in deliberate misuse terms. For motorists this includes the potential for blocking back associated with the nearby junctions and cars pulling out straight onto the crossing and on occasion causing damage to the barriers.

In terms of make-up, the road surface and gradient is unlikely to impact on the ability of a vehicle to stop behind either stop line. At the estimated road speed, the visibility of level crossing signage and equipment is considered compliant and provides road users with surplus time to react if the crossing is activated.

For pedestrians, despite the presence of a pedestrian bridge adjoining Mortlake station, this has not deterred deliberate pedestrian misuse i.e. something which was identified on the date of the last assessment as well as during cyclical asset inspections. Pedestrian movements are likely to have increased during the peak period in recent years with children both accompanied and unaccompanied being the predominate users.

In 2015 the associated level crossing manager lodged objections against a development of a Free School development in close proximity to the crossing. This development later went ahead but subject to assurances from the School and further to a proposed safety analysis, revised travel plans necessitating school coordination with Network Rail, and regular education with the parental attendees which has since been continually progressed.

Present at these meeting were developers, BTP (British Transport Police), Metropolitan Police and the school governors. Network Rail has also liaised with the schools in the area providing safety seminars and parental 'Q and A' sessions and has provided internal funding for the provision of additional signs to aid users to encourage use of the station bridge.

With the Stag Brewery development there is a probability (yet to be established) that the primary risk at the crossing will emerge as a 'pedestrian-vehicle' related risk with rail risk being secondary. With associated congestion and by virtue of the developments proximity to the crossing, pedestrians are likely to be forced into the path of vehicles on either side of the crossing when the barriers are lifted. This conflict will also arise from the congestion caused by the extensive barrier downtime at this site and the inability to provide more waiting space and pavement width. This concern arises despite the presence of a suitable bridge at Mortlake, something which is not available at its neighbouring crossing White Hart Lane and, which experiences similar issues. It is unlikely that another bridge structure at the site would solve this problem.

There has also been tasking of the British Transport Police enforcement vehicle throughout the years at Mortlake which has been productive but does not allow or account for enforcement for deliberate pedestrian misuse and is restricted to enforcing vehicle contraventions. The table below show the results from various 'tasking dates' at the crossing.

Crossing name	Date	Total Time (hh:mm)	No. of drivers captured	No. of pedestrians observed offending	Total no. of vehicles
Mortlake	06/12/2011	05:00	19	4	1,760
Mortlake	22/12/2011	06:45	13	0	2,310
Mortlake	16/01/2012	03:15	0	2	1,369
Mortlake	02/02/2012	03:30	7	5	1,396
Mortlake	07/02/2012	03:00	6	8	1,100
Mortlake	29/02/2012	03:00	6	3	1,142
Mortlake	21/03/2012	03:00	3	0	921
Mortlake	28/03/2012	03:45	2	5	924
Mortlake	30/05/2012	03:30	14	9	1,501
Mortlake	02/07/2012	03:30	3	7	1,675
Mortlake	27/09/2012	04:15	9	8	1,720
Mortlake	02/10/2012	02:30	5	0	1,020
Mortlake	09/10/2012	03:00	0	0	1,009
Mortlake	24/10/2012	03:30	8	0	1,593
Mortlake	08/11/2012	03:00	3	0	1,844
Mortlake	15/11/2012	03:00	8	0	1,337
Mortlake	29/11/2012	02:15	2	0	1,259
Mortlake	03/12/2012	03:00	4	0	1,863



Mortlake	12/12/2012	03:00	4	0	1,776
Mortlake	18/12/2012	03:00	2	6	1,682
Mortlake	29/01/2013	03:00	3	9	1,553
Mortlake	05/02/2013	03:00	4	7	1,887
Mortlake	25/02/2013	03:00	7	9	1,426
Mortlake	28/03/2013	01:00	0	0	402
Mortlake	16/05/2013	03:00	3	15	1,205
Mortlake	12/06/2013	03:15	5	6	1,477
Mortlake	25/06/2013	02:15	2	9	473
Mortlake	03/07/2013	03:00	8	5	2,026
Mortlake	24/07/2013	03:30	7	4	1,078
Mortlake	12/09/2013	03:10	5	7	4,055
Mortlake	13/01/2014	03:15	4	6	902
Mortlake	09/12/2014	03:30	8	16	2,549
Mortlake	11/12/2014	03:30	2	13	2,756
Mortlake	18/12/2014	03:30	7	15	2,341
Mortlake	15/01/2015	03:45	3	18	3,233
Mortlake	03/02/2015	04:00	7	17	2,682
Mortlake	26/06/2015	07:45	13	40	7,504
Mortlake	12/10/2016	03:20	0	4	2,187
Mortlake	24/10/2016	03:20	1	4	1,960
Mortlake	13/01/2017	03:20	2	2	1,207
Mortlake	07/02/2017	03:15	0	0	1,928
Mortlake	13/02/2017	03:20	0	6	2,145
Mortlake	01/06/2017	03:30	0	5	1,765
Mortlake	08/06/2017	03:05	3	4	1,307
Mortlake	12/06/2017	03:30	0	1	998

## 2.6 Vegetation Risk

Vegetation management is occasionally an issue on the upside of the crossing, which arises during cyclical inspections but is generally rectified as and when required. There are no other known issues and at the last inspection all vegetation was compliant.

## 2.7 ALCRM (All Level Crossing Risk Model) Scores

The current risk assessment score on ALCRM is E2\* with a FWI scoring of 3.47E-02. As mentioned previously, this score makes it the 4<sup>th</sup> riskiest CCTV crossing on the Wessex Route, and places it in the high risk category. The following key risk drivers were identified by the ALCRM toolset and contributed to the risk score as follows:

- Frequent trains
- Crossing near station
- Large number of users

\* The ALCRM (All Level Crossing Risk Model) provides a prediction of risk which it classifies in the following ways:

- Individual risk of fatality (identified by a letter A (high) to M (low)), which relates to the risk of death for an individual using the crossing on a frequent basis (500 times per year); and
- collective risk (identified by a number 1 (high) to 13 (low)), which relates to the total risk generated by the crossing. This takes into account the overall risk of death and injury for crossing users, train crew and passengers.

Note: The ALCRM tool can give a rather limited output about hazards around residual risk or misuse. It is not possible to use ALCRM to properly assess the risk from a wide range of hazards.

### 3.1 BARRIER DOWN-TIME ANALYSIS

Barrier down-time at Mortlake has been a contentious issue which has had escalation to the ORR, the Wessex Executive and Wessex Operations throughout the years. The high frequency of trains at the crossing, and other contributing factors, means that information from barrier downtimes displayed below gave values where the average barrier down time for non-rail users at Mortlake is 03:59 minutes outside peak hours which averages 40:39 minutes down-time per hour, and 04:40 minutes during peak hours with 46:32 down time minutes per hour.

	Time of day	North Sheen	Mortlake	White Hart Lane	Barnes (Richmond)
Average barrier down time (mm:ss)	Full day	03:41	03:59	03:50	03:52
Average barrier downtime per hour (mm:ss)		39:13	40:39	40:21	40:12
Average barrier down time (mm:ss)	Peak	04:26	04:40	05:15	05:33
Average barrier downtime per hour (mm:ss)		46:32	46:45	47:13	52:43

This snapshot of data is from a report published in the latter part of 2016 and there is likely to be a slight variation in barrier down times from day to day and may alter subject to unforeseen events as well as operational delays.

There has been no change in the services within the area since which would warrant further review of those timings however, as the scale shows, it is imperative that this crossing is not reviewed in isolation and must incorporate the other crossings within the Richmond area. If a closure option was later considered for Mortlake Level Crossing, then it may be feasible that the surrounding traffic could seek alternative routes which perhaps may increase vehicle and pedestrian usage at the other crossings as well as introducing additional risk.

This in turn requisites the necessity for cross collaboration with stakeholders and in particular for collaboration and the insistence for substantive pedestrian and traffic/census modelling relative to the Stag Brewery site. An increase in Rail Traffic at this site would also increase barrier downtime adversely at the site to unacceptable levels.

### 3.1 OPTION ASSESSMENT

This section reviews the various options available to mitigate risk and reduce it to acceptable levels. These options are then reviewed with a cost benefit analysis to see if they satisfy the spend in return for a proportionate reduction in risk.

In line with ORR guidance, closure is always the first option that has to be investigated.

#### **4.1 Closure via diversion / road Rail Bridge**

In November 2013 Network Rail were questioned in Parliament by the Transport Select Committee over the safety of level crossings and were challenged to close crossings wherever feasible. This crossing is situated in an urban area with multiple roads leading to it. There are alternative ways of traversing the railway further away from the crossing however, it is the understanding of this assessment that closure via diversion is currently not possible due to the high usage and lack of suitable diversionary routes within the immediate vicinity of the crossing. This position may change subject to future feasibility studies arising from upcoming meetings with various stakeholders.

Extinguishment and diversion was partially mooted circa 2014/2015 by the Wessex Level Crossing team but later discounted as unfeasible save for a large-scale redevelopment programme, e.g. a Crossrail type project. It was also envisaged locally that a tunnel option may allow for closure to be realised but could cost in excess of £10m although this figure remains notional. A road rail bridge was also considered not to be feasible due to location, absent a similar type of project and well as its proximity to the station with the possibility of land purchase options (again a notional figure of £6m was optioned). This may alter further to the Stag Brewery development and thus these have been optioned as part of this assessment. Together with the notional figures provided both options failed a cost benefit analysis review (CBA).

#### **4.2. Red Light Enforcement Cameras (RLSE)**

A bespoke enforcement camera is an option that has been applied to reduce vehicle misuse at another London Crossing in Richmond (White Hart Lane) and has recently passed Home Office approval and could similarly be applied to Mortlake. The camera has automatic number-plate recognition software and would be able to penalise/prosecute vehicles that ran the red-light at the crossing. This would not have an impact on pedestrian misuse which is a significant concern nor would it prevent pedestrian/motorist interaction. Furthermore, it may not have a preventative impact to tackle deliberate vehicle misuse which is a predominate concern there. In risk terms the attributable reduction to the overall risk scorings would be minimal (around 2%) and installation would be cost prohibitive (potentially £200k+).

This option has failed a Cost Benefit Analysis (see below) however may be suitable if external funding with the local authority/Highways/developer was an option but this would not be recommended as a risk reduction option here. This provision would also necessitate additional maintenance costs and ongoing process costs with Staffordshire Police, the current custodian of RLSE contraventions. This option has merely been progressed for documentary purposes.

#### **4.3 Renewal of the crossing**

Expanding the width of the crossing and/or the footpath approach access may be an interim option to allow for additional pedestrian room. Notwithstanding that such an upgrade does not stack up under a cost benefit analysis (as per similar studies for other crossings) this would again require external contributions as there is no quantifiable risk reduction benefit for Network Rail and therefore no equivalent balance of finance.

Initial assessments suggest that this is not possible unless there is a full/partial renewal of the crossing and as such justification for such an alteration is unlikely to be passed. In fact for Mortlake it is likely that more land would be required for us to be able to expand the crossing and would impede on existing structures and rights of way. Failing that altering the current 'crossing footpath' may create pinch points thus potentially trapping users within the barriers. Therefore in order for these to have some impact it would necessitate significant works. This would include barrier lengthening, pedestal removal, surface renewal, re-signaling alignment /interfacing, the shortening of adjacent conductor rail as well as ancillary works.

Working in accordance with national standards and combined with feasibility studies and possession requirements, this option is expected to realise at least £400k for a partial renewal or a full renewal of £2.7 besides the other aforementioned factors. It is unlikely that this can be achieved within the current or subsequent control periods (CP5/CP6).

## 5.1 COST BENEFIT ANALYSIS

Option	Term <sup>1</sup>	ALCRM risk score	ALCRM FWI	Safety Benefit	Cost	Benefit Cost Ratio	Status	Comments
Renewal of crossing partial	Long Term	E2	3.34E-02	0	£400k	0.04	REJECTED	Safety and business option case fails CBA.
Renewal of crossing Full	Long Term	E2	3.34E-02	0	£2.7 m	0.01	REJECTED	Safety and business option case fails CBA.
Tunnel Structure with Closure	Long Term	M13	3.34E-02	3.34E-2	£10m	0.15	REJECTED	Safety and business option case fails CBA.
Road Rail Bridge with Closure	Long Term	M13	3.34E-02	3.02E-04	£6m	0.25	REJECTED	Safety and business case fails CBA.
Red Light enforcement	Long Term	E2	2.13E-02	1.02E-04	£200k	0.02	REJECTED	Safety and business option case fails CBA.

## 6 CONCLUSION AND RECOMMENDATION

Rail risk is not a significant concern at Mortlake Level Crossing by virtue of the fact that it is a CCTV controlled crossing. This means that the majority of the risk is controlled by the full barriers separating road users from the trains and the signaller protecting the crossing

ensuring that a train cannot approach unless the crossing is clear. This then leaves the potential risk arising from pedestrians who are struck as a result of a contravention or, error on their part i.e. as opposed to railway failures or errors.

The main risk is a vehicular risk to pedestrians from general road users and more so road users who deliberately misuse the crossing. This is not helped by the current width of the footpaths on both approaches and specifically user congestion during peak hours. This does not mean that the footpaths on the actual crossing are deficient as they are compliant but, with the possibility of increased usage /congestion this may present an issue in the future.

Resolving the wider issue of congestion (both road and pavement) does not rest solely with Network Rail but is also the responsibility of the local council and Highway teams. It is imperative that a Borough-wide strategy of traffic management, enforcement, collaboration on building developments as well as possible regeneration plans are considered by these parties. Network Rail has already taken steps to assist in reducing deliberate misuse by progressing engagement with external parties. The presence of an existing station footbridge, something of which is unavailable at Mortlake's neighbouring crossing White Hart Lane, should alleviate the deliberate misuse at Mortlake although this is still prevalent. This has been countered by education and enforcement, Many of the schools in the vicinity have received guidance to parents and children. Also, the British Transport Police are regularly tasked to the crossing in order to avert misuse.

It is important to emphasise that whilst a footbridge is being considered for White Hart Lane as a partial solution, Mortlake has almost similar usage at the crossing and is likely to see increased usage should the Stag Brewery development proceed in the years to come and thus has the potential to adversely congest the area around the crossing during barrier down-times. A brief census analysis was also conducted to review the current bridge usage at Mortlake station in 2016 and initial findings suggest that the bridge may not be used as much and therefore this would question justifying further spend or, may warrant other logical solutions for consideration.

This in turn prompted the provision of additional signage at the site to encourage usage of the bridge but the problem remains; particularly during the peak hours and has the potential to get worse. It is also a type of risk which not it is easily quantifiable, would require in-depth pedestrian movement analysis as well as high level evaluations with the local authority equally incorporating their considerations as well as establishing available risk prioritisation funding amongst other things.

Expansion of the crossing and approaching pavements is undoubtedly cost prohibitive and may also necessitate land grab as well as station redevelopment as outlined within the options sections above. Whilst the option has a notional costing, the true cost of land grab cannot be determined at this stage and this may not reduce congestion. Moreover expanding the crossing would not provide a risk reduction for Network Rail as the crossing type would remain identical. In fact, it may increase the risk should more users traverse. Alternatively the other RLSE camera option is also only likely to reduce risk minimally and also does not pass a CBA for funding.

On that basis it is the recommendation of this assessment, with an impending development looming that closure with diversion or, via a road Rail Bridge remains the best option. However, whether this is achievable remains to be seen and will requisite complex modelling, feasibility studies, in depth census analysis as well as collaboration with Richmond authorities and possible developers. As the crossing currently has the highest form of signaller protection and a footbridge, funding from Network Rail is unlikely so a solution is likely to be wholly dependent on S106 or CIL contributions arising from developments in the area.

Therefore, even though Network Rail is currently managing the risk as far as is reasonably practical at Mortlake it is the recommendation of this risk assessment for Network Rail to engage with the local council/developers to not only establish possible user impact but to broach mitigation options. At the time of writing a meeting with representatives of the developer is planned for August 2017.

## 6 APPROVALS

Prepared By: Mark O'Flynn	Signature: Held on file
	Job Title: Level Crossing Manager
Date: 26 <sup>th</sup> July 2017	
Approved By: [REDACTED] (RLCM)	Signature: Held On File
	Job Title:



## **Appendix B NR letter to Zac Goldsmith MP**

Zac Goldsmith MP  
House of Commons  
London  
SW1A 0AA

**Our Ref:** ATZGRPC005

26 October 2017

Dear Mr Goldsmith,

I am writing to you regarding Mortlake level crossing following our meeting on the proposed Stag Brewery development.

Mortlake level crossing offers the highest level of protection for users. Further detail is in the attached risk assessment. Risk at the site is from deliberate misuse and vehicular and pedestrian interaction, which is increased by congestion at the site when the barriers are lowered. However, the crossing is safe when used correctly.

We are concerned the significant increase in residential units and new school from the proposed development would increase usage of the crossing, especially by unaccompanied young people and other vulnerable users. Pedestrian usage is already near maximum capacity and any further increase would compromise safety in relation to user interaction.

To manage this risk, we believe the developer should fund the cost of integrating the development with railway infrastructure, and in particular the crossing. Richmond Borough Council would need to coordinate this. We are requesting a meeting with the developer to discuss our concerns and measures it could fund, such as a ramped footbridge. However, if our concerns are not addressed we would strongly consider objecting to the development through the planning process.

It is highly unlikely we would have a business case to fund a ramped footbridge, given the existing protections. Widening the footways would mean moving essential crossing equipment, costing millions of pounds, which we are not funded to deliver. Closing the crossing and installing an underpass or overbridge would cost tens of millions and be severely disruptive. This is not feasible.

We met the Mortlake Brewery Community Group, copied to this letter, recently to discuss the development and the implications of increased usage of the crossing. We will reference its independent research on the crossing, showing heavy usage and deliberate misuse, with the developer.

In the meantime, we will look into improving road and footway markings at the crossing and work with Richmond Borough Council. We are also looking into signage at the footbridge to encourage usage with the station operator. However, these upgrades are behavioural nudges and will not alone manage risk from increased usage.

We have investigated using countdown timers at full barrier crossings, such as Mortlake crossing, but have discounted this. Barrier down time is determined by a number of factors, including station dwell time and varying speeds of oncoming trains. It would be very difficult to predict accurately how long each wait time could be. We will be looking into signage to show the average or worse case wait time, to encourage drivers to switch off their engines.

It is vital the strategic plan for Mortlake and the surrounding area is integrated with railway infrastructure. There are a number of level crossings in the authority area and these must be considered as a whole in planning, rather than in piecemeal. We will be writing to the Chief Executive and Leader of Richmond Borough Council to request a meeting to discuss the development and the authority's wider strategic transport plan.

It is worth noting, we cannot support increased frequency of trains on the line via Richmond unless barrier down time at level crossings in south west London is addressed. If a scheme allowed trains to run between London Waterloo and Heathrow Airport, services would need to take existing train paths, run via Hounslow or services via Richmond would need to run as non-stopping services to reduce barrier down time (which we anticipate would be unacceptable to passengers). Any other future increases in services will need to run via Hounslow.

I hope this information is helpful. We will contact you again to update following further meetings. If you have any questions in the meantime, please contact me through our route public affairs manager, Aeneas Tole, on [aeneas.tole@networkrail.co.uk](mailto:aeneas.tole@networkrail.co.uk) or 07734 650 550. I would be grateful if you could share this letter with those who attended the recent meeting.

Yours sincerely

A handwritten signature in black ink, appearing to read "Stewart Firth". The signature is fluid and cursive, with the first name being more prominent.

**Stewart Firth**  
**Director of Route Sponsorship, Wessex**

cc Robert Orr Ewing, Chair, Mortlake Brewery Community Group