

Arboricultural Method Statement & Tree Survey Report (BS5837:2012)



Proposed Construction of a Swimming Pool Building at Barnes Home Guard, Richmond Park Road, East Sheen, London, SW18 8LA

July 2019
Revision A 07.08.19

Prepared by



Encon Associates Limited
10 Chapel Lane
Arnold
Nottingham
NG5 7DR

Date of Report: 3 July 2019
Report Reference: A4018 Revision A (07.08.19)
Issued by: MJB
Checked by: GM

Contents

Executive Summary	4
1 Introduction.....	7
2 Limitations & Methodology	7
Third Party Liability.....	8
Subsistence Risk	8
Survey Methodology	8
3 Project Requirements & Site Overview	11
Site Context	11
Proposed Development	11
Tree Preservation Orders (TPO) or Conservation Area (CA) Designation	11
Existing Trees on Site	12
Root Protection Area (RPA)	13
5 Tree Protection Plan.....	14
6 Arboricultural Method Statement.....	15
Protective Fencing Prior to Commencement of Work.....	15
Tree Pruning	15
7 Conclusions.....	18
Appendix A - Schedule of Trees	20
Appendix B - Tree Survey Plan & Tree Protection Plan	21
Appendix C - Demolition and Construction in Proximity to Existing Trees.....	22
Appendix D - Photographic Record.....	27
Appendix E - Tree Preservation Order (TPO)	29

Executive Summary

This report is based on the Tree Survey Report dated 12 December 2018 and has been updated in accordance with the following Planning Condition from London Borough of Richmond upon Thames dated 25 April 2019:

U0060555 AMS

Prior to the commencement of development, an Arboricultural Method Statement (AMS), shall be submitted to and approved in writing by the Local Planning Authority.

The AMS must:

(A) Be written in accordance with and address sections 5.5, 6.1, 6.2, 6.3 and 7 of British Standard 5837:2012 Trees in relation to design, demolition and construction - recommendations

(B) Be written in conjunction with the schemes specific method of construction (where applicable)

(C) Outline any tree constraints, and explain any impacts for both above and below ground.

(D) Detail all tree protection and ground protection for landscaping (including plans)

(E) Detail any special engineering for construction within the Root Protection Area or retained trees.

(F) Detail any facilitation pruning that may be required. The specification for tying back and/or pruning must be measurable and prepared by a suitably qualified Arboriculturist. All tree work must be undertaken in accordance with BS3998:2010 Tree work - Recommendations unless approved by the Councils Arboricultural Officer

(G) Provide confirmation of the appointment of an Arboricultural Consultant for the duration of the development and a schedule of inspections too achieves an auditable monitoring and supervision programme, and a timetable for submission to the Local Planning Authority.

The development shall not be implemented other than in accordance with the approved AMS.

REASON: To ensure that the tree (s) are not damaged or otherwise adversely affected by building operations and soil compaction.

The trees on and in proximity to this site have been assessed in accordance with BS 5837:2012 "Trees in relation to design, demolition and construction - Recommendations".

The proposal is for the construction of a new swimming pool building at 76A, Barnes Home Guard, Richmond Park Road, East Sheen, London SW18 8LA.

The report includes a survey of 4 individual trees located within proximity of the proposed building at Barnes Home Guard.

The site comes under the planning jurisdiction of the London Borough of Richmond Council and correspondence with the planning department confirms that there are no trees on the site that are protected by Tree Preservation Orders. The site is not located in a Conservation Area, however the houses that border the site to the west are within a Conservation area, which means that some trees located just off the site have conservation status.

The trees included in this survey are located to the west of the site, where the proposed building is proposed to be constructed. There are two existing trees within the application site and two other trees located beyond the western boundary of the site. Four different species are present, including Silver Birch, Yew, Beech and English Oak.

Three of trees have been classified as C2 ie trees of low quality including the Silver Birch located on site. The English Oak tree also within the applicants ownership has some merit and is a reasonable tree with the potential to develop into a good specimen and has been classified as category B2 tree, ie trees of moderate quality.

There were no trees classified as category U trees, ie trees which are dead, dying or with serious defects with no long term merit for retention. There are no trees on site classified as category A1 ie high quality or particular visual importance.

Based on the current proposed extension plans, no trees included in the survey will require removal to facilitate the work. However, the single silver birch tree (T1) of limited quality is proposed for removal. Some pruning of branches of the yew tree (T2) within the rear garden of an adjacent property will need to be cut back to prevent conflict with the new pool building.

The location of the proposed pool building encroaches within the Root Protection Area (RPA) of two trees (T2 and T3) which has the potential to be detrimental to the survival of the trees should damage occur to the roots.

Following discussion with the design team, the footprint of the proposed pool building has been reconfigured to move it further away from the existing trees as far possible to reduce the impact on the adjacent trees and therefore protect them from detrimental damage during the construction of the pool and the building.

As long as the recommendations within this report are fully adhered to, the impact of the development will be kept to a minimum and will not be detrimental to the long term survival of the adjacent trees.

1 Introduction

1.1 The advice contained within this survey report has been prepared for Barnes Home Guard and their design team in respect of existing trees on the proposed construction of a swimming pool building in the south-west corner of the Barnes Home Guard site, Richmond Park Close, East Sheen SW14 8LA in order to:

- Assess the quality of the Trees in proximity to the proposed building work
- Investigate any legal protection of the trees
- Provide an Arboricultural Assessment with regard to the proposals
- Recommend measures which will suitably protect the trees during the construction process

1.2 Following the initial site visit, preparation of the tree survey and discussion period with the design team, arboricultural information is provided within this report in accordance with BS5837:2012.

1.3 The report is based on the following drawings which have been supplied by the client:

- As existing & proposed plan, drawing number 1624-08 PO1, by Reigate Architects, dated 13/06/2018
- Proposed swimming pool, Drawings 1441.05A BHGA revised footprint 12 Dec 2018 by Buckland Pool & Building Company

2 Limitations & Methodology

2.1 The survey is concerned with the arboricultural aspects of the site only. The trees, on site have been surveyed and classified in accordance with BS 5837:2012 "Trees in relation to design, demolition and construction - Recommendations".

2.2 The survey was undertaken using the Visual Tree Assessment (VTA) methodology to conduct a preliminary assessment of the above ground portion of the tree.

2.3 Trees are large dynamic organisms whose health and condition can change rapidly, therefore due to their changing nature and other site considerations, this report and any recommendations made are valid for a 12 month period following the site survey which was conducted on Wednesday 21st November 2018. After a period of 5 years, the information in this survey should not be relied upon.

Third Party Liability

2.4 The limit of Encon Associates Limited indemnity over any matter arising out of this report extends only to the instructing client. Encon Associates Limited cannot be held liable for any third party claim that arises following this report.

Subsistence Risk

2.5 This report is primarily concerned with the condition of existing trees and the application of current guidance for their retention. Any discussion of soil characteristics is only presented where this may have a direct effect on tree growth. This report does not seek to address the specific area of subsidence risk assessment or damage to buildings or structures.

Survey Methodology

2.6 The survey was undertaken from ground level with the aid of binoculars where necessary.

2.7 No aerial inspection nor invasive probing or drilling has been undertaken. No excavations were carried out nor soil or root samples taken.

2.8 The height of each subject tree was measured on site using an electronic Disto measuring device.

2.9 The canopy spread of each subject tree was measured on four compass points using measuring tape.

2.10 The locations of the trees have been plotted on the proposed site plan based on positions indicated on the existing site plan provided. We cannot guarantee the absolute accuracy of tree locations; however, the positions are believed to be accurately represented on the plan based on the GPS locations used by the surveyor. Encon Associates cannot be held responsible for any discrepancy in the position of the trees.

2.11 The information contained within the “Schedule of Trees” includes the following for each surveyed tree:

- 1 **Tree reference number** - cross referenced with the Tree Survey Plan A4018-01 and Tree Constraints Plan A4018-02.
- 2 **Species** - have been given their common and botanical name where specifically known
- 3 **Height** - measured on site using an electronic Disto measuring device
- 4 **Stem diameter** - have been calculated by measuring the circumference at a height of 1.5m from ground level to determine the diameter
- 5 **Branch spread** - the circles indicated on the tree survey plan are a representation of the overall spread of the crown in each compass direction
- 6 **Height of crown clearance** - given in metres above adjacent ground level
- 7 **Age class** - young (YNG) up to 10 years, semi-mature (SM) 1/3 life expectancy, early mature (EM) 2/3 life expectancy, mature (M) over 2/3 life expectancy, over mature (OM) declining/moribund, veteran (V) exceptionally old tree towards the end of its life, (D) dead
- 8 **Condition & Comments** - good (G) sound tree needing little or no attention, fair (F) minor but rectifiable defects, poor (P) major structural and/or physiological defects that would be inappropriate to retain and/or expensive, dead (D) no longer alive or those dying and unlikely to recover. General observations on ‘physiological/structural condition’ and ‘preliminary management’ is also provided
- 9 **Estimated remaining contribution** - in years eg <10, 10+, 20+ and 40+
- 10 **Category grading** - have been given a grade to classify the quality of each tree based on the Condition Classes and subcategories given overleaf
- 11 **RPA** - Protective measures as per BS 5837 section 4.6 which states that an area based on a radius equal to 12 times the stem diameter should be protected

against damage to roots known as the “Root Protection Area” (RPA) given in m². A radius has also been given shown around each tree on the drawing.

2.12 Category grading for the assessment of tree quality (in accordance with Table 1 "Cascade chart for tree quality assessment" within BS 5837:2012) is described below:

U Trees unsuitable for retention - Those in such a condition that they cannot be realistically be retained as living trees in the context of the current land use for longer than 10 years

A Trees of high quality - With an estimated remaining life expectancy of at least 40 years

B Trees of moderate quality - With an estimated remaining life expectancy of at least 20 years

C Trees of low quality - with an estimated remaining life expectancy of at least 10 years, or young trees with a stem diameter below 150mm

2.13 Subcategories grading for the assessment of tree quality (in accordance with Table 1 "Cascade chart for tree quality assessment" within BS 5837:2012) is described below:

1 Mainly arboricultural qualities - Trees that are a particularly good example of their species, especially if rare or unusual

2 Mainly landscape qualities - Trees, groups or woodlands of particular visual as arboricultural and/or landscape features

3 Mainly cultural values, including conservation - Trees, groups or woodlands of significant conservation, historical, commemorative or other value eg veteran trees or wood-pasture

For full description of subcategories, refer to Table 1, page 9 of the BS 5837:2012 document.

3 Project Requirements & Site Overview

Site Context

- 3.1 The location of the proposed work currently consists of unused land at Barnes Home Guard. The site currently has a building in the north-east corner that has a bar, a lounge that holds regular social functions, and a kitchen. The majority of the site consists of mown grass, with an area of hardstanding to the south of the site, on which the proposed building will be built.
- 3.2 Barnes Home Guard is located in central East Sheen, south of the River Thames. The land surrounding the site is predominantly residential, as the site is located behind the rear gardens of properties on Richmond Park Road, Sheen Lane, and Shrewsbury Avenue.

Proposed Development

- 3.3 The proposal is for the construction of a new swimming pool building on land in the south western corner of Barnes Home Guard.

4 Baseline Factors

Tree Preservation Orders (TPO) or Conservation Area (CA) Designation

- 4.1 The site comes under the planning jurisdiction of the London Borough of Richmond Council and correspondence with the planning department confirms that there are no trees on the site that are protected by Tree Preservation Orders. The site is not located in a Conservation Area, however the houses that border the site to the west are within a Conservation area, which means that some trees located just off the site have conservation status.

Existing Trees on Site

4.2 There are 2 trees within the site boundary within the applicant's ownership and 2 other trees beyond the western boundary within the back gardens of adjacent houses. Species include a Silver Birch and English Oak on site and a Yew and Beech beyond the western boundary.

4.3 3 of these have been classified as category C2 i.e. trees of low quality. The fourth tree (English Oak, T4) has been categorised as B2 i.e. tree of moderate quality. There were no category U trees, i.e. trees which are dead, dying or with serious defects. There were no category A trees, ie high quality of particular visual importance.

4.4 The following table provides an assessment of the impact on each tree:

Tree Ref	Species	Category Grading	Remove/ Retain	Potential Impact	Comments
T1	Betula pendula	C2	Remove	Medium	Footprint of the new building lies within the RPA. The new building encroaches under the tree canopy is 2.7m from the building. The tree is to be removed by applicant as part of the construction works.
T2	Taxus baccata	C2	Retain	Medium	Footprint of the new building encroaches 25% into the RPA. The new building is 1.4m from the trees trunk and encroaches into the canopy and therefore needs to be crown lifted to give sufficient clearance for the new building to be clear of the canopy.
T3	Fagus sylvatica	C2	Retain	Medium	Footprint of the new building encroaches 13% into the RPA. The new building is 1.9m from the trees trunk and encroaches into the canopy however there is sufficient clearance to prevent the building from conflicting with the branches.
T4	Quercus Robur	B2	Retain	Low	Footprint of the new building lies outside of the RPA. The new building is 3.4m from the trees trunk. The proposed Pool Building does not encroach into the branches of the existing tree

- 4.5 Details of the locations and Root Protection Areas (RPA) are provided on the Tree Constraints Plan (TCP) appended to this report.
- 4.6 A schedule of trees and their condition including their category grading and RPA radius is attached in Appendix A.

Root Protection Area (RPA)

- 4.7 The Root Protection Area (RPA) of a tree is defined in BS5837 as the area surrounding the trunk that contains sufficient rooting volume to ensure the survival of the tree and is calculated as an area based on the stem diameter of the tree.
- 4.8 The RPA's have been calculated in accordance with BS5837 and are detailed in the Tree Schedule located in Appendix A of this report. Where ground constraints have, or are likely to have, had an effect on tree root development, for example, where level changes or changes in rooting medium eg heavily compacted ground, areas of hard standing etc, have influenced tree root growth, the RPA is unlikely to follow an exact circle and will probably be more elliptical in shape.
- 4.9 Detailed analysis of the ground conditions has not been carried out, however a visual assessment concluded that 2 of the trees were located off-site, very close to the boundary fence.
- 4.10 Tree root systems are typically concentrated within the uppermost 600mm of the soil, although it may be deeper within the dense mass of roots and soil closer to the base of the tree. The development of the root system is influenced by the availability of water, nutrients, oxygen and soil penetrability ie how compacted the ground is and therefore the root spread does not generally show the symmetry seen in the branch system. The roots of some of the trees are likely to have been influenced by their proximity to adjacent structures and paving, although others appear to be well established trees offering valuable visual amenity to the area.

5 Tree Protection Plan

- 5.1 This section considers the implications that the proposed development may have upon the existing trees adjacent to the site and provide advice on solutions to any issues to ensure the trees are safeguarded.
- 5.2 In accordance with Section 5.5 of BS5837:2012, a Tree Protection Plan (TPP) has been produced and is provided in Appendix B of this report.
- 5.3 Following discussion with the design team, the location of the proposed building has been reconfigured to move the footprint away from the existing trees off site as far as possible to minimise the impact on the trees.
- 5.4 The footprint of the new pool and building encroaches into the RPA of T2 by 25% and T3 by 13%. BS5837:2012 states an encroachment of no more than 25% into the RPA should not be detrimental to the long term survival of the tree.
- 5.1 As the trees are located off site and not under the ownership of the applicant, permission from the owner is required prior to carrying out any pruning works on them and all precautions must be taken to ensure the trees are not damaged which could impact on their long term survival, including damage to their root zones.
- 5.2 Other trees within the application site owned by the applicant can be removed without the need for an application as they are not covered by a Tree Protection Order. However, if any of the trees are outside the applicant's ownership, then they cannot be removed and must be protected. Prior to the removal of any trees, the contractor and/or tree surgeon appointed to carry out the works must ensure any necessary regulations and/or licences in accordance with BS5837 are complied with and in place.

6 Arboricultural Method Statement

6.1 This section provides details for tree protection in accordance with Section 6.1, 6.2 and 6.3 of BS5837:2012.

Protective Fencing Prior to Commencement of Work

6.2 The existing trees to be retained should be protected from damage during construction operations by fencing them off from machinery circulation routes and material storage areas. The distance from the trees to the construction activity is such that damage could occur and therefore construction vehicles should be prevented from unwittingly travelling too close to the trees and causing damage to overhanging branches or compaction of the root zone. Protective fencing as detailed in the Appendix C of this report should be erected in front of the line of trees.

Tree Pruning

6.3 The working and access space needed for the construction of the proposed development will require “access facilitation pruning” carried out to two of the trees which currently overhang the site boundary to prevent injurious contact between construction plant and the tree canopy. In particular, it is anticipated that the canopy of T2 and T3 may come into contact with the roof of the proposed building. A one-off tree pruning operation, which is directly necessary to provide access for operations on site, is acceptable in accordance with BS5837 as long as “the nature and effects of the pruning are without significant adverse impact on the tree physiology or amenity value”.

6.4 All proposed tree works should be undertaken prior to the commencement of construction activities.

6.5 It is noted that the canopy from T2 and T3 may come in contact with the proposed roof which overhangs the building by a maximum of 300mm, therefore pruning of the

branches of the two trees is recommended prior to the construction works, in order to prevent contact between the trees and roof. In addition, T2 is also recommended for a crown lift to prevent contact with the roof of the building.

6.6 Trees on site which have been identified to have their crowns lifted and/or formative pruning must be carried in accordance with BS3998 British Standard Tree Work - Recommendations 2010 by a competent tree surgeon to the following specification:

- Where practicable, pruning should be restricted to healthy, small diameter parts of the tree to minimise the size of resultant wounds and enable these to be occluded.
- Crownlift to achieve a clearance of at least 4m above ground level to include complete removal of the lowest primary branches and thereafter secondary and tertiary branches (not exceeding 50mm diameter cuts). When pruning branches back to the main stem or fork, the branch will be removed in small sections using the step cut method leaving a small stub before carrying out the final cut.
- Formative pruning to branches 20mm and less in diameter to be pruned cleanly back to its point of origin, avoiding damaging the bark of the tree and ensuring the canopy maintains a natural shape. Growth greater than 20mm is to be cut back to avoid damage to the branch bark ridge and collar if applicable. All pruning carried out using a sharp handsaw or secateurs. On no account will a chainsaw be used in this operation. All shoots will be removed back to, but not into the branch collar leaving no projections or exaggerating the size of the wound.

Site Monitoring

- 6.7 In accordance with 6.3 of BS5837:2012, there should be an auditable system of site monitoring which includes arboricultural supervision whenever construction activity is to take place within or adjacent to any RPA.
- 6.8 The applicant confirms they have appointed Encon Associates Limited to monitor site activity based on the following programme of works:

Programme of Works

Operation	Date
Start on site	5 th August 2019
Site set up and clearance	5 th - 12 th August 2019
Excavations of foundations and pool	12 th August - 7 th October
Construction of building	7 th October 2019
Landscaping works	24 th February 2020
Practical completion	March 2020

- 6.9 Site inspections will be carried out a strategic times during the works. The initial visit will be carried out at the beginning of the work to ensure the tree protection measures are in place and correctly installed. A second visit will be carried out during the excavation works to supervise works in proximity to the existing trees and RPA's. Other inspections will be carried out at critical times during the works as necessary. A final inspection will be carried out towards the completion of the work to ensure it has been completed in accordance with this AMS.
- 6.10 All visits will be recorded, including photographs and compiled into a written report as documentary evidence, suitable for issuing to the Local Planning Authority.

7 Conclusions

7.1 The trees on this site have been assessed in accordance with BS 5837:2012 "Trees in relation to design, demolition and construction - Recommendations".

7.2 The conclusion of the survey are as follows:

- There are 2 trees on site and 2 trees beyond the western boundary in close proximity to the proposed report includes a survey of 4 individual trees located within proximity of the proposed swimming pool and building
- The site comes under the planning jurisdiction of the London Borough of Richmond Council and correspondence with the planning department confirms that there are no trees on the site that are protected by Tree Preservation Orders. The site is not located in a Conservation Area, however the houses that border the site to the west are within a Conservation area, which means that some trees located just off the site have conservation status.
- Three of trees have been classified as C2 ie trees of low quality including the Silver Birch located on site. The English Oak tree also within the applicant's ownership has some merit and is a reasonable tree with the potential to develop into a good specimen and has been classified as category B2 tree, ie trees of moderate quality.
- There were no trees classified as category U trees, ie trees which are dead, dying or with serious defects with no long term merit for retention. There are no trees on site classified as category A1 ie high quality or particular visual importance.
- Based on the current proposed extension plans, no trees included in the survey will require removal to facilitate the work. However, the single silver birch tree (T1) of limited quality is proposed for removal. Some pruning of branches of the

yew tree (T2) within the rear garden of an adjacent property will need to be cut back to prevent conflict with the roof of the new pool building.

- The location of the proposed pool building encroaches within the Root Protection Area (RPA) of two trees (T2 and T3) which has the potential to be detrimental to the survival of the trees should damage occur to the roots.
- Following discussion with the design team, the footprint of the proposed pool building has been reconfigured to move it further away from the existing trees as far possible to reduce the impact on the adjacent trees and therefore protect them from detrimental damage during the construction of the pool and the building.
- The footprint of the new pool and building encroaches into the RPA of T2 by 25% and T3 by 13%. BS5837:2012 states an encroachment of no more than 25% into the RPA should not be detrimental to the long term survival of the tree.

7.3 As long as the recommendations within this report are fully adhered to and replacement tree planting is included in the new development, the impact of the development and loss of existing trees will have a minimal impact to the visual amenity of the locality as the majority of the existing woodland will be retained.

Appendix A - Schedule of Trees

Appendix B - Tree Survey Plan & Tree Protection Plan

Encon Associates - DISCLAIMER:

This drawing is copyright and shall not be reproduced or used for any other purpose without the written consent of Encon Associates. Encon Associates is not liable for any errors or omissions in this drawing. The information contained herein is for the sole use of the client and is not to be used for any other purpose. Encon Associates is not responsible for any actions taken by the client or any third party based on the information contained herein. The client is responsible for ensuring that all information provided is accurate and complete. Encon Associates is not responsible for any actions taken by the client or any third party based on the information contained herein. The client is responsible for ensuring that all information provided is accurate and complete. Encon Associates is not responsible for any actions taken by the client or any third party based on the information contained herein. The client is responsible for ensuring that all information provided is accurate and complete.

Notes:

Key to Tree Survey Plan

The RPA (Root Protection Area) is the zone in which the roots of a tree are likely to cause damage. It has been calculated for each tree within the site boundary. The results can be found with the Tree Report.

This drawing is based on:

- As Exhibits B, Proposed Plan, drawing number 1624408 P01, by Reigate Architects, dated 13/06/2018
- Proposed swimming pool, Drawings 1441_05A
- BHEA revised footprint 12 Dec 2018 by Buckland Pool & Building Company
- Site visit by Encon Associates, 21.11.18

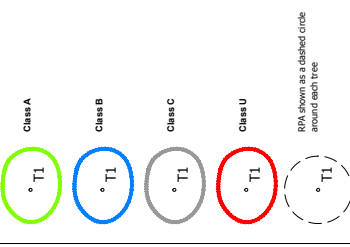

Rev	Date	Description	Drawn	Checked
Client				
Ian Phillips				
Project				
Barnes Home Guard Association 76A Richmond Park Road SW14 9JA				
Title				
Tree Survey Plan				
Drawing Status				
FOR PLANNING APPROVAL				
Drawn				
MBJ				
Checked				
EK				
Date				
26.11.18				
Scale (A1)				
1:200				
10 Chapel Lane Nottingham NG5 7DR				
encon Environmental Consultants to the Construction Industry				
11115191019 • E: info@encon.co.uk • W: www.encon.co.uk				
11115191019 • E: info@encon.co.uk • W: www.encon.co.uk				
11115191019 • E: info@encon.co.uk • W: www.encon.co.uk				
11115191019 • E: info@encon.co.uk • W: www.encon.co.uk				
Job Number	Drawing Number			Rev
A4018	A4018			01

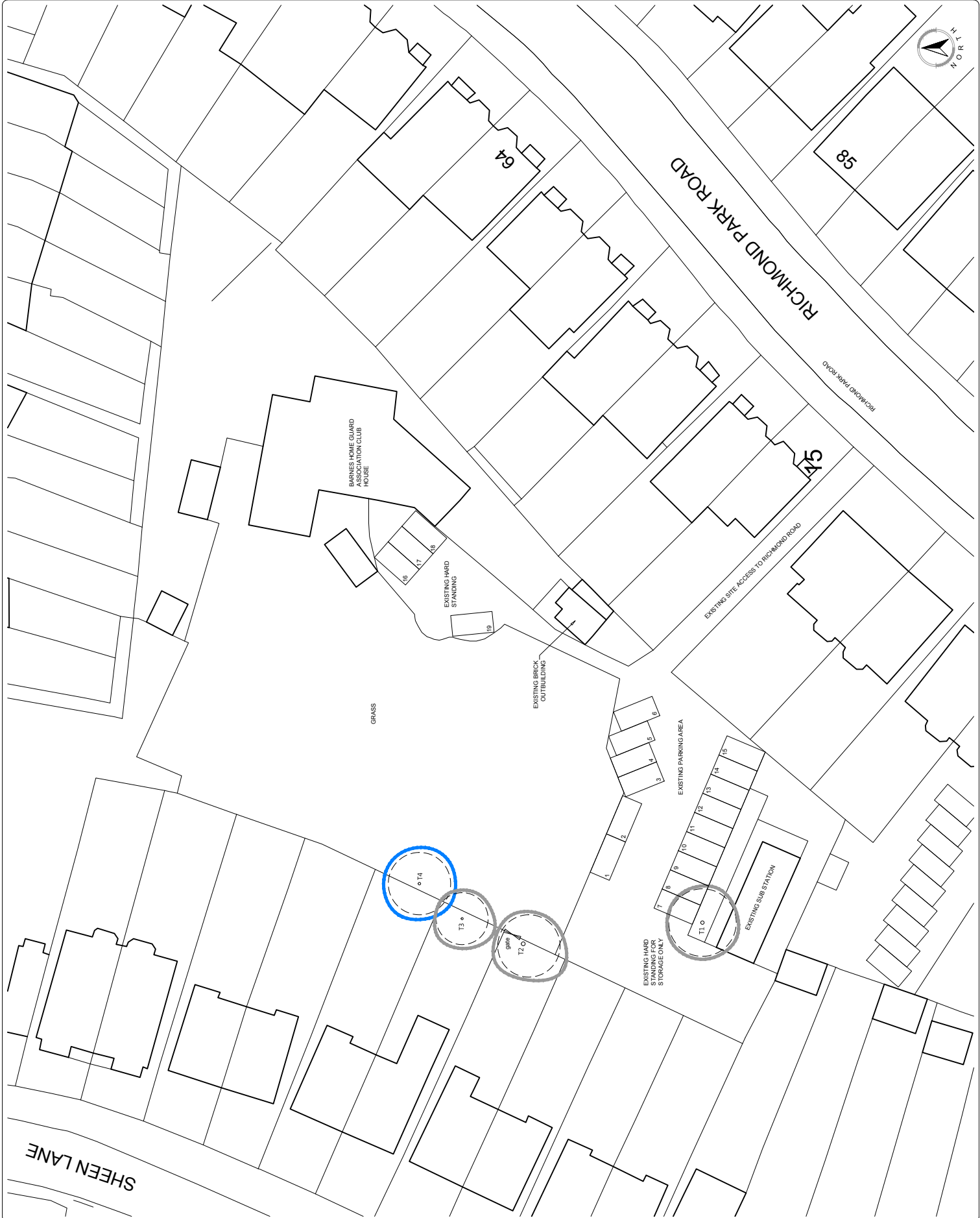

Appendix C - Demolition and Construction in Proximity to Existing Trees

In accordance with Section 7 of BS5837:2012, the contractor should carry out the works in accordance with the following:

1.1 Root Protection Area (RPA)

The RPA required by the current edition of BS 5837:2012 relates to the stem diameter of each tree when measured at a height of 1.5m from ground level, adjusted where necessary to account for actual rooting patterns on site. The RPAs are to be afforded protection at all times and will be protected by fencing barriers. No works will be undertaken within any RPA that causes compaction to the soil or severance of tree roots.

2.0 Protective Fencing

A protective fence should be erected prior to the commencement of any site works e.g. before any materials or machinery are brought on site, any construction work starts or any stripping of soil commences. The barrier needs to have signs attached stating that this is a Tree Protection Area and that no works are permitted within the barrier. The barrier may only be removed following completion of all construction works.

2.1 The fence is required to be sited in accordance with the TCP. The fence must ideally be constructed as per figure 2 in BS 5837:2012 (see detail at the end of this section) and be fit for the purpose of excluding any construction activity. The construction on site should be excluded from the RPA with 'Heras' type Fencing construction, along with a formal briefing of any work person by the site manager with regards to the contents of this method statement.

3.0 Precautions in respect of Temporary Works

If temporary access is required to an RPA then access may only be gained after consultation with the Local Planning Authority and following placement of materials

such as geo-textile fabrics that will spread the weight of any vehicular load and prevent compaction to the soil. For pedestrian movements within any RPA then a single thickness scaffold board on top of a compressible layer laid onto a geotextile fabric may be acceptable. Otherwise, there should be no access within the RPA at any time during the contract.

4.0 Access Details

There is no requirement for any special measures related to the retained trees if access for all construction vehicles is kept away from the trees to be retained and stay outside of the RPA.

5.0 Contractors Car Parking

This is likely to be within the existing car park area onsite. The area designated for parking needs to be away from the area around the trees to be retained.

6.0 Site Huts and Toilets

The area designated for site accommodation needs to be away from the area around the trees to be retained.

7.0 Storage Space

The storage of materials should ideally be on existing hard standing away from existing trees. The contractor should not store any materials on site within the RPA of an existing tree.

8.0 Additional Precautions

No storage of materials or lighting of fires should take place within the RPA. No mixing or storage of materials should take place up a slope where they may leak into an RPA.

8.1 No fires to be lit within 20 metres of any tree stem and the fire size and wind direction should be taken into account so that, no flames come within 5.0m of any foliage.

8.2 No high-sided vehicles or cranes should access the site close to any trees to be retained and should not come into contact with any branches or travel within the RPA

8.3 No notice boards, cables or other services to be attached to any tree.

8.4 Materials which may contaminate the soil should not be discharged within 10m of any tree stem. When undertaking the mixing of materials it is essential that any slope of the ground does not allow contaminants to run towards a tree root area.

9.0 Site Gradients

No alterations of soil levels to take place within the RPA of the protected trees

10.0 Demolition Works

No demolition works to take place within the RPA of the protected trees

12.0 Soft landscaping

Please refer to the landscaping proposals.

13.0 Use of Herbicides

No herbicide use is predicted, however if used, it should be done so in strict accordance with the manufacturer's instructions and contact with any tree foliage should be avoided.

14.0 On Site Monitoring Regime

All operations to be monitored by the main contractor. The site manager shall contact the appointed specialist if there is a breach of the RPA and tree protection measures. The appointed specialist shall recommend an action plan to incorporate mitigation measures where necessary.

17.0 Remedial Tree Works

The recommended tree works should be undertaken prior to the commencement of construction activities. All tree works are to be carried out in accordance with BS 3998 British Standard Tree Work - Recommendations 2010. Permission must be granted by the local authority prior to working on any tree protected by a Tree Preservation Order. Failure to do so may result in prosecution.

18.0 Responsibilities

It will be the responsibility of the main contractor to ensure that planning conditions are adhered to at all times and that a monitoring regime in regards to tree protection

is adopted on site and ensure any necessary licences are in place prior to any felling and all relevant regulations are adhered.

18.1 The main contractor will be responsible for contacting the Local Planning Authority at any time issues are raised related to the trees on site.

18.2 The main contractor will ensure the build sequence is appropriate to ensure that no damage occurs to the trees during the construction processes. Protective fences will remain in position until completion of ALL construction works on the site.

18.3 Protective fencing should be erected around all trees to be retained as per the following specification:

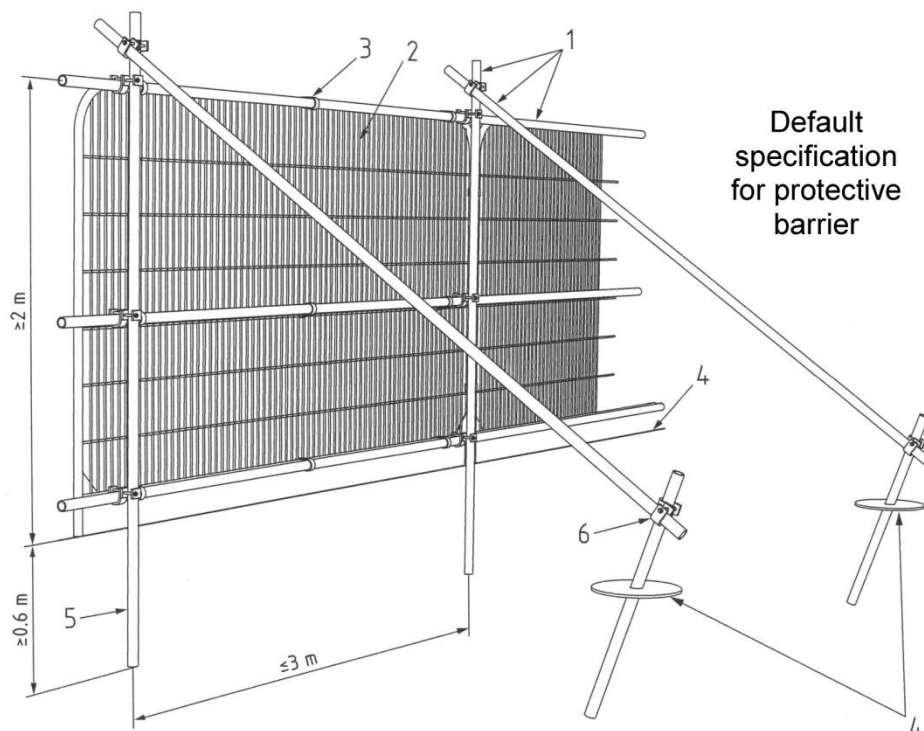

Key

- 1 Standard scaffold pole
- 2 Heavy gauge 2m tall galvanised tube and welded mesh infill panels
- 3 Panels secured to uprights and cross-members with wire ties
- 4 Ground level
- 5 Uprights driven into the ground until secure (minimum depth 0.6m)
- 6 Standard scaffold clamps

18.4 Signs, in accordance with the following example, should be displayed to inform all personnel where the tree protection areas are and to warn them not to enter.

Example of "Keep Out" Sign:

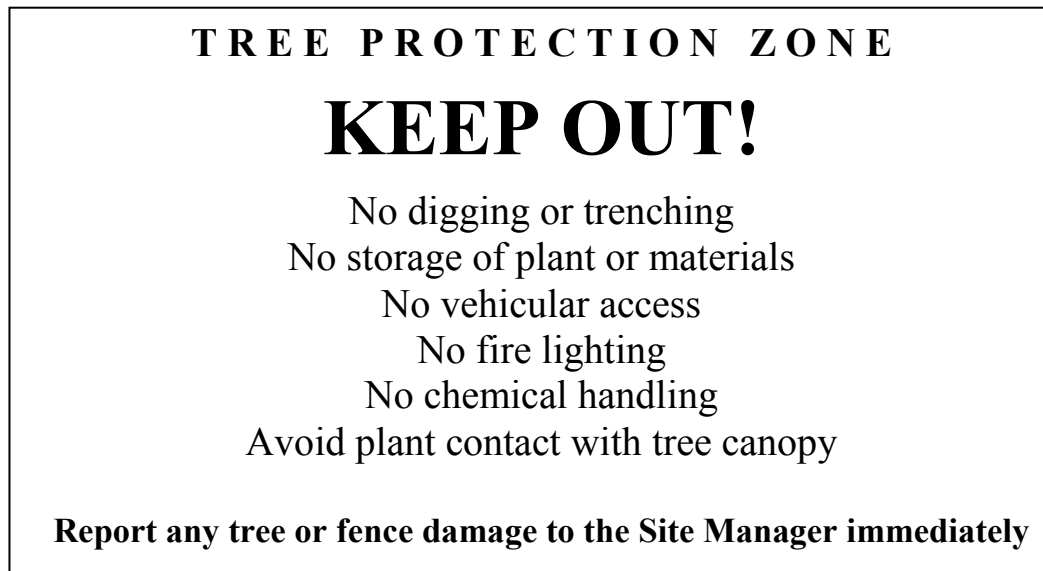

Appendix D - Photographic Record



Photo 1 - View of the Silver Birch (T1)



Photo 2 – View of the Yew Tree (T2) that is located off-site.



Photo 3 – View of T3, a Beech tree that is located off site.



Photo 4 – View of the category B English Oak (T4)

Appendix E - Tree Preservation Order (TPO)

Mark Bentley

Subject: TPO information Barnes Home Guard DS

From: David Short <D.Short@richmond.gov.uk> **On Behalf Of** Trees & Parks

Sent: 23 November 2018 14:11

To: Emily Kempson <emily@enconassociates.com>

Subject: RE: TPO information Barnes Home Guard DS

Dear Ms Kempson

Unfortunately as the map system we use to check the conservation area status is copyrighted, I am unable to send a copy. I can confirm though that all properties bordering the Barnes Home Guard site on the west side, are within the Sheen Lane Conservation Area, No. 64.

We are conducting a Customer Experience Survey to gather customer feed-back to help improve our services. The survey only takes 5 minutes and can be completed by using the link below and selecting Customer Services.

www.richmond.gov.uk/customer_feedback

If you require any further assistance please do not hesitate to contact us.

Kind regards,

David Short
Corporate Customer Services
London Borough of Richmond upon Thames
Tel: 020 8891 1411

For information about all the services provided by the London Borough of Richmond upon Thames please visit:

<http://www.richmond.gov.uk>

You can also follow us on Twitter for up to date information and news:

Twitter [@LBRuT_Help](https://twitter.com/LBRuT_Help)

From: Emily Kempson [<mailto:emily@enconassociates.com>]

Sent: 22 November 2018 15:46

To: Trees & Parks

Subject: RE: TPO information Barnes Home Guard DS

Hi David,

Thank you for getting back to me, would it be possible for you to send me a map showing the conservation area please? I have looked on the conservation area map on your website but it is difficult to see exactly what lies within the conservation areas.

Regards

Emily Kempson BSc (Hons)
Graduate Environmental Consultant



From: David Short <D.Short@richmond.gov.uk> **On Behalf Of** Trees & Parks
Sent: 22 November 2018 15:38
To: Emily Kempson <emily@enconassociates.com>
Subject: RE: TPO information Barnes Home Guard DS

Dear Ms Kempson

Thank you for your email.

I have checked our records and the Barnes Home Guard site is not within a Conservation Area and there are no TPO's on site either. All properties bordering the site on the western side are though in a Conservation Area.

We are conducting a Customer Experience Survey to gather customer feed-back to help improve our services. The survey only takes 5 minutes and can be completed by using the link below and selecting Customer Services.

www.richmond.gov.uk/customer_feedback

Once again thank you for your email. If you require any further assistance please do not hesitate to contact us.

Kind regards,

David Short
Corporate Customer Services
London Borough of Richmond upon Thames
Tel: 020 8891 1411

For information about all the services provided by the London Borough of Richmond upon Thames please visit:

<http://www.richmond.gov.uk>

You can also follow us on Twitter for up to date information and news:

Twitter [@LBRuT_Help](https://twitter.com/LBRuT_Help)

From: Emily Kempson [<mailto:emily@enconassociates.com>]

Sent: 21 November 2018 16:54

To: Trees & Parks

Subject: TPO information Barnes Home Guard DS

Good afternoon,

I am emailing to enquire as to whether any trees on the site shown in the map below are protected by a tree preservation order, or are within a conservation area. The address of the site is Barnes Home Guard Association, 76A Richmond Park Road, SW14 8LA.

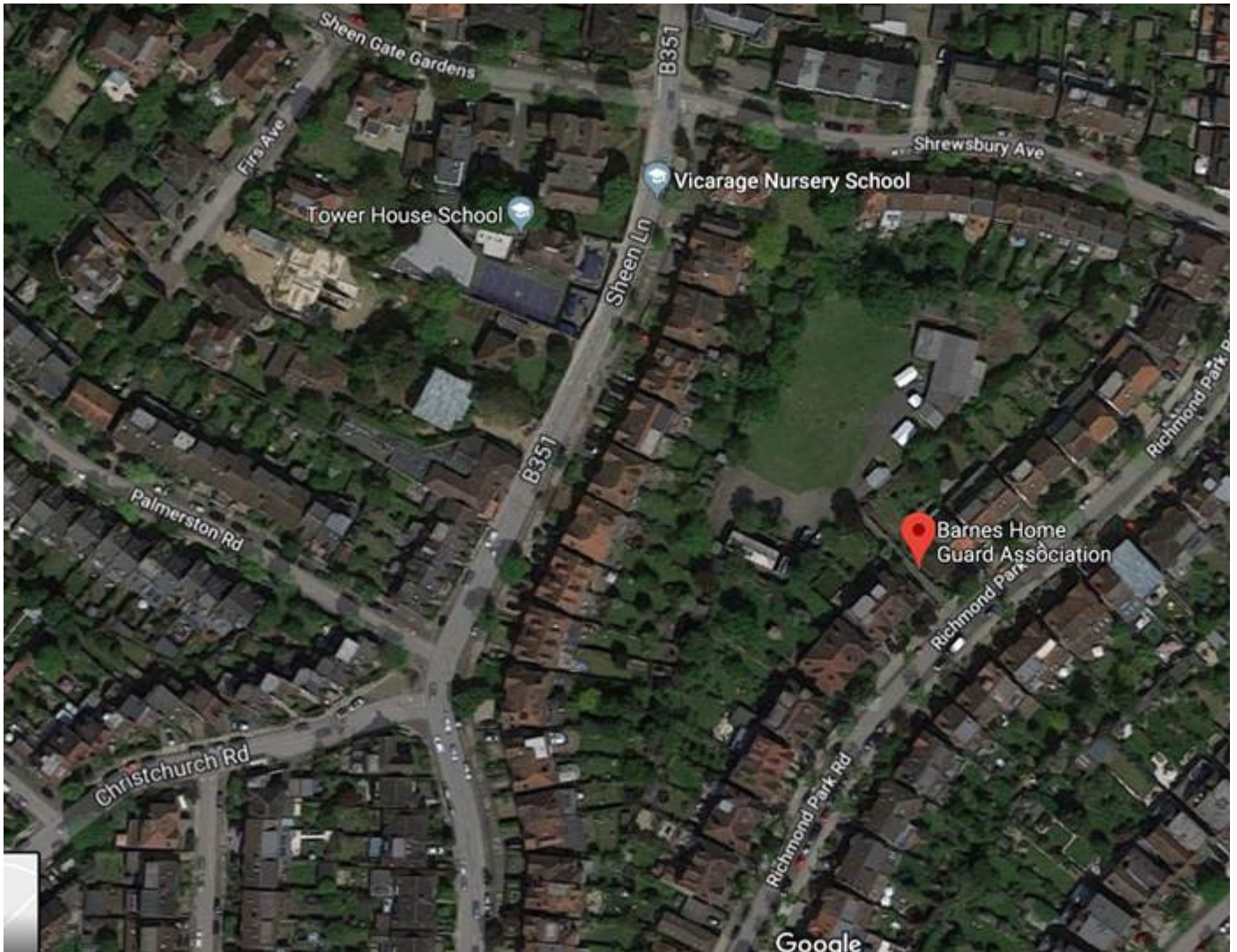

I look forward to hearing from you

Regards

Emily Kempson BSc (Hons)
Graduate Environmental Consultant



Environmental Consultants to the Construction Industry

- BREEAM ■ Code for Sustainable Homes ■ Landscape Architecture
- Highway Engineers ■ Swept Path Analysis ■ Energy Assessment
- SAP ■ EPC ■ SBEM ■ Daylight Calculations ■ Ecology ■ SWMP

Nottingham	London	Leeds
10 Chapel Lane Nottingham NG5 7DR	85 Great Portland Street London W1W 7LT	15 Queen Square Leeds LS2 8AJ
0115 987 55 99	0203 949 99 38	0113 468 60 60