

All work to comply with current building regulations and codes of practice
 Do not scale from drawings all dimensions to be checked on site before the start of any work
 All Proposed External Materials to Match Existing External Materials

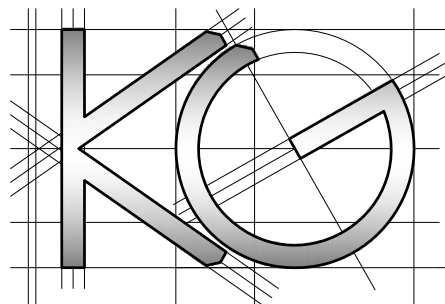
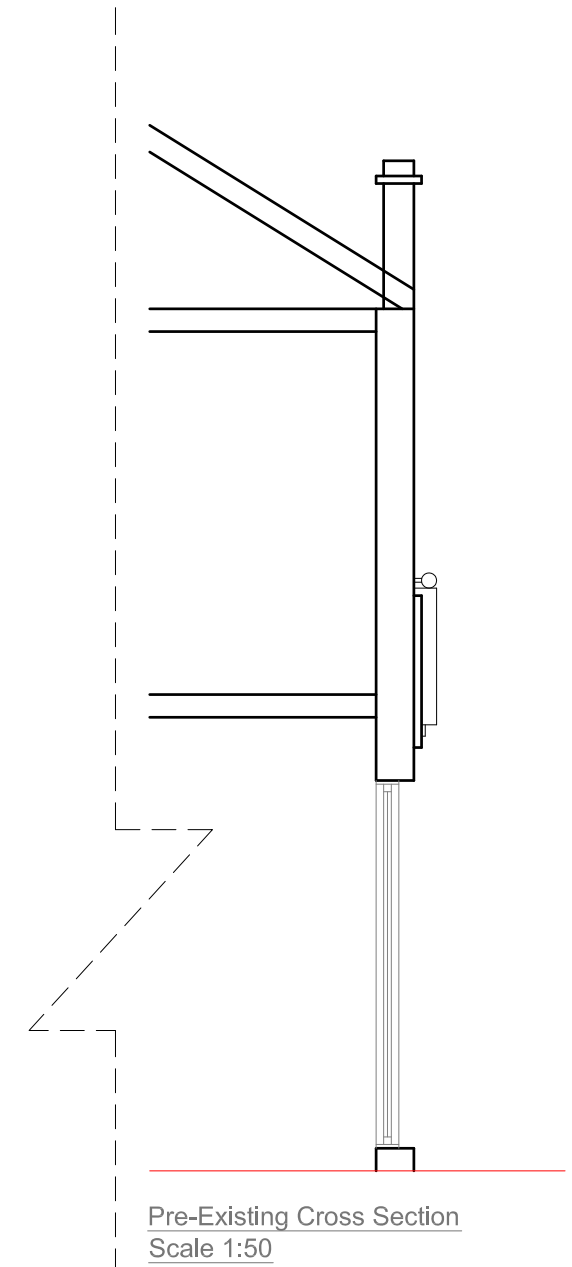
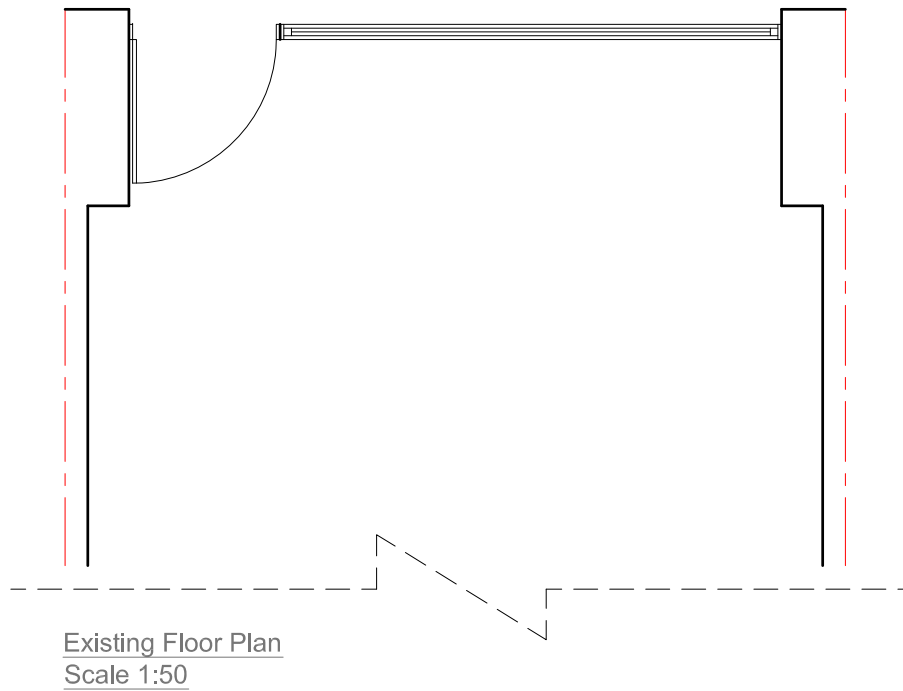
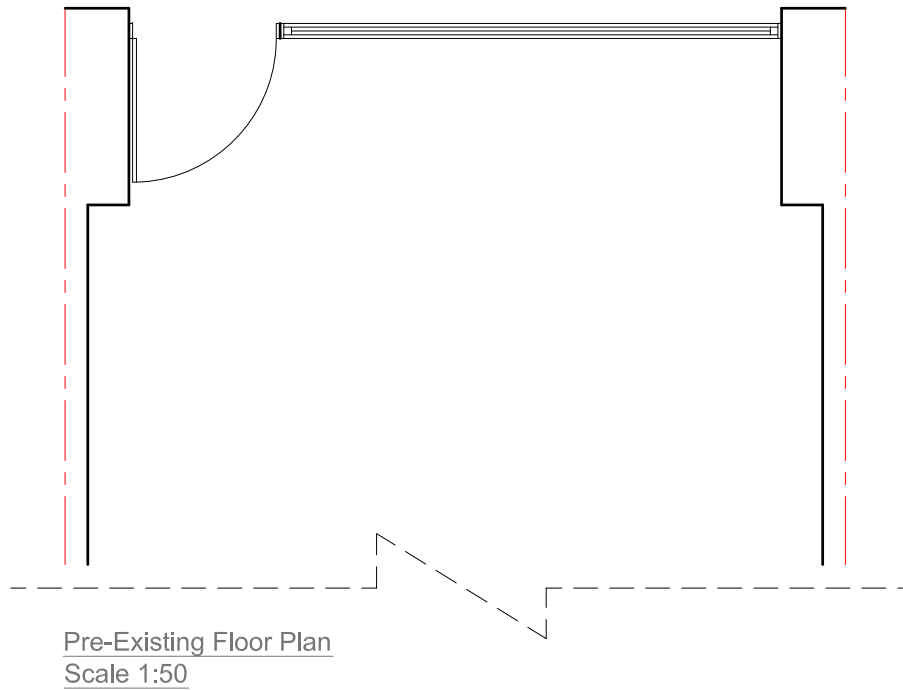

<u>Site Address:</u> 31 High Street Whitton TW2 7LB	<u>Drawing Content:</u> Pre-Existing Ground Floor Plan, Elevation & Cross Section	<u>Drawings No:</u> 31highstreet/2024/01	<u>Date Drawn:</u> 28th March 2024	Planning Issue		
				<u>Drawings Scale:</u> 1:50	<u>Drawn By:</u> KG	<u>Revision:</u>
1	2	4	6	05 24	8	8