

EXISTING ROOF PLAN

MAIN ROOF AREA MEASURE AT ROOF PLAN 72m²

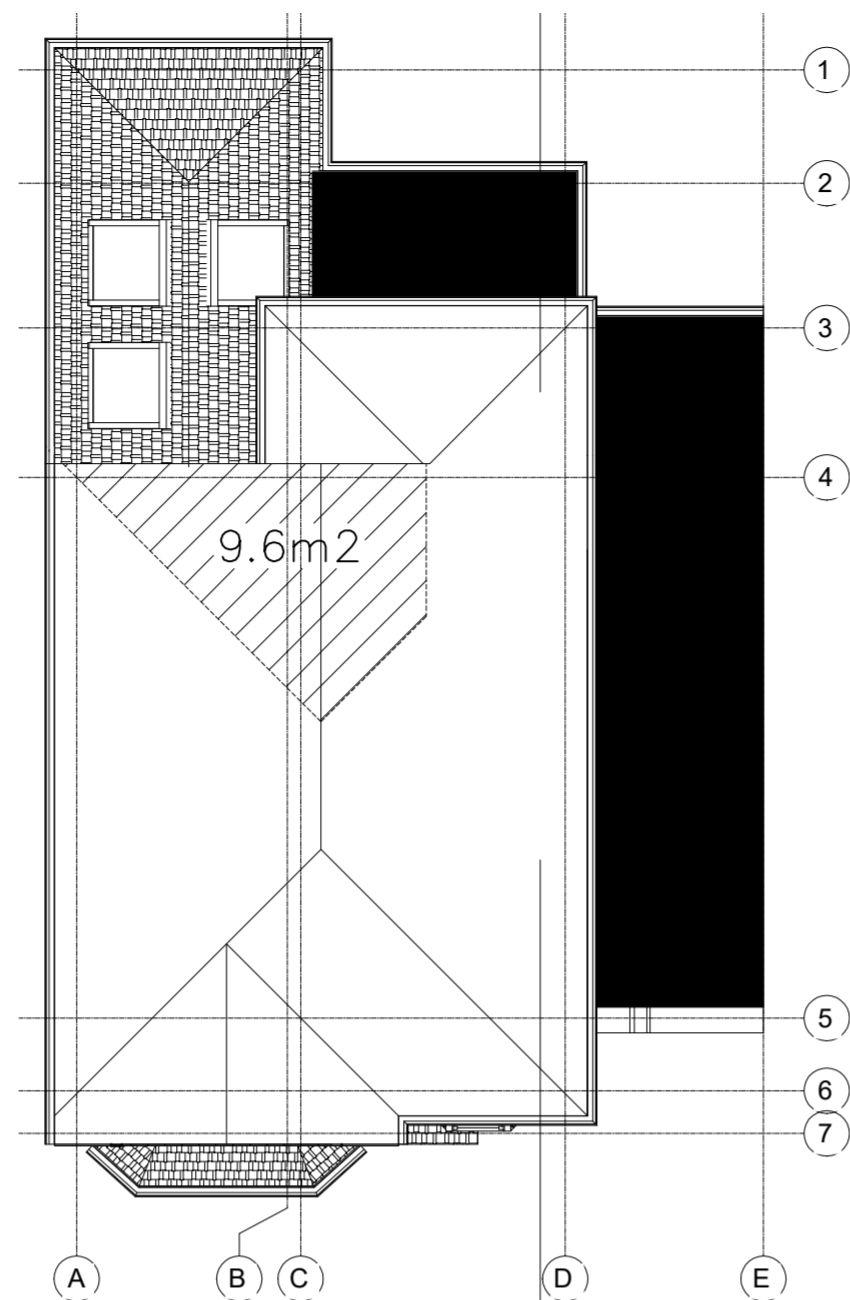

BUILDING STAGE - GABLE END

MAIN ROOF TO BE EXTENDED TO THE REAR

REQUIRED DEMOLISHED ROOF AREA MEASURE AT ROOF PLAN 9.6m²

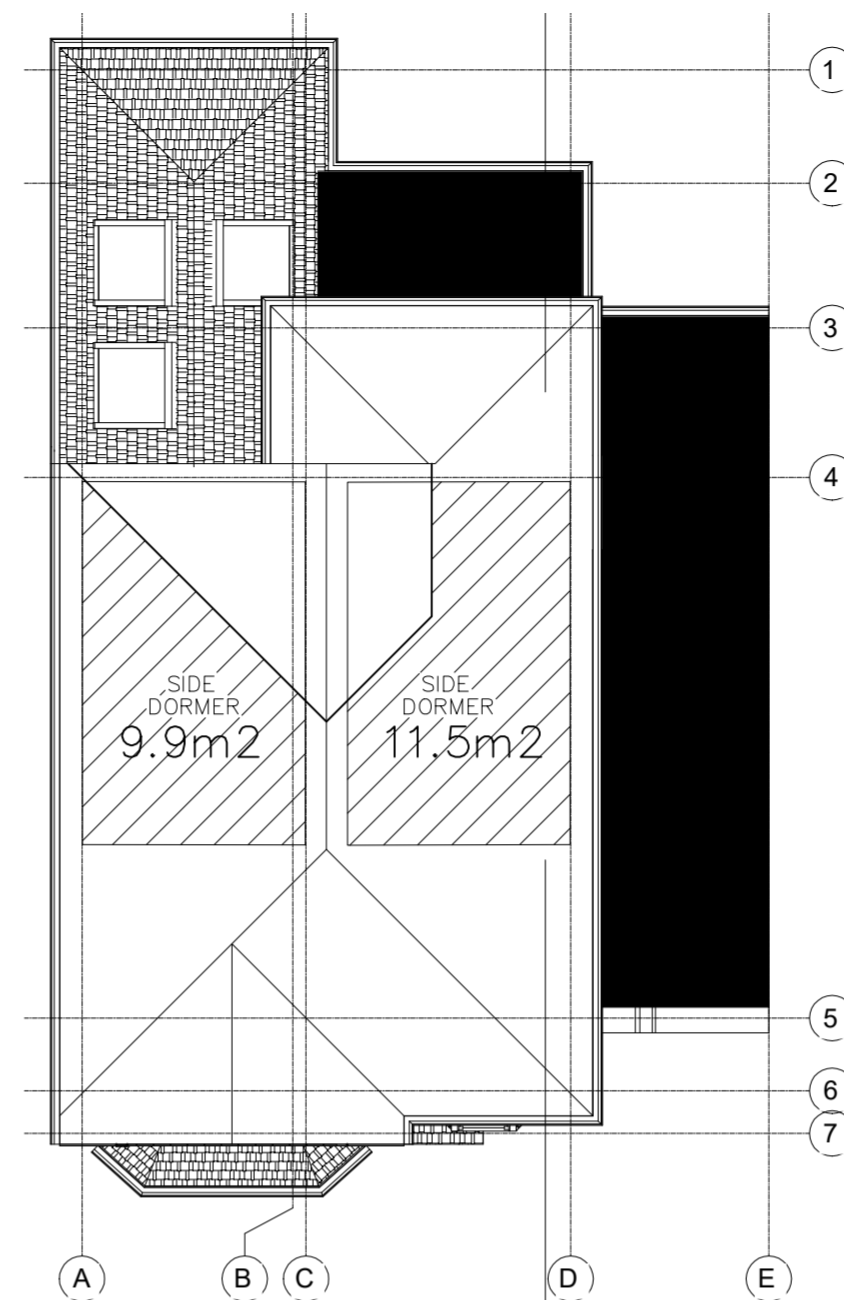

BUILDING STAGE - 2 X SIDE DORMERS

MAIN ROOF TO BE EXTENDED TO THE BOTH SIDES

REQUIRED DEMOLISHED ROOF AREA MEASURE AT ROOF PLAN 9.9m² + 11.5m²

TOTAL REQUIRED DEMOLISHED ROOF AREA MEASURE AT ROOF PLAN
 $9.6m^2 + 9.9m^2 + 11.5m^2 = 31m^2$ (43% OF EXISTING ROOF - REMAIN 57%)

PLANNING STATEMENT

THE PROPOSAL WILL NOT REQUIRED TO DEMOLISHED THE WHOLE ROOF

MORE THEN 50% OF THE ORIGINAL ROOF WILL REMAIN

PLEASE REFER TO THE CALCULATIONS

TO COMPARE STANDARD LOFT CONVERSION WITH GABLE END AND REAR DORMER REQUIRED MORE THEN 50% OF ORIGINAL ROOF TO BE DEMOLISHED AND NORMALLY IS ACCEPTABLE UNDER PERMITTED DEVELOPMENT

TYPICAL SEMI DETACHED HOUSE WITH GABLE END AND REAR DORMER SAMPLE NORMALLY APPROVE UNDER PERMITTED DEVELOPMENT FOR LOFT CONVERSION

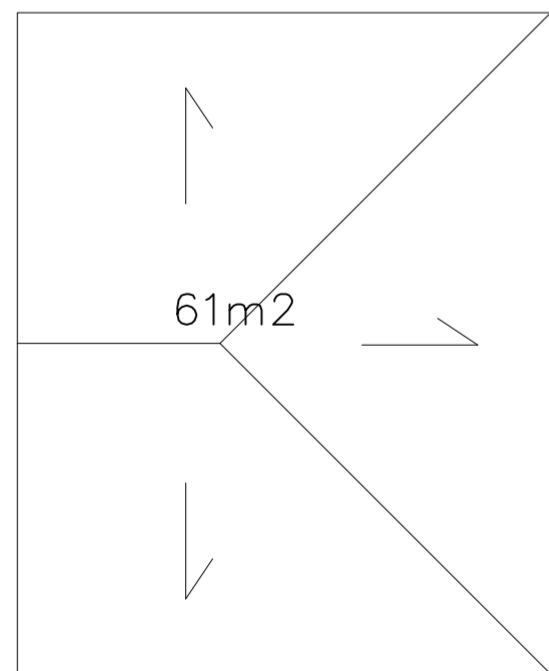

EXISTING ROOF PLAN

MAIN ROOF AREA MEASURE AT ROOF PLAN 61m²

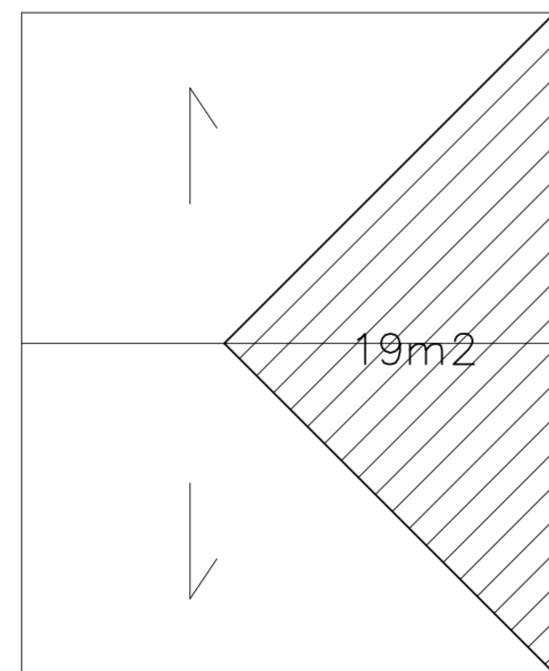

BUILDING STAGE ONE - GABLE END TO THE SIDE

MAIN ROOF TO BE EXTENDED TO THE SIDE

REQUIRED DEMOLISHED ROOF AREA MEASURE AT ROOF PLAN 19m²

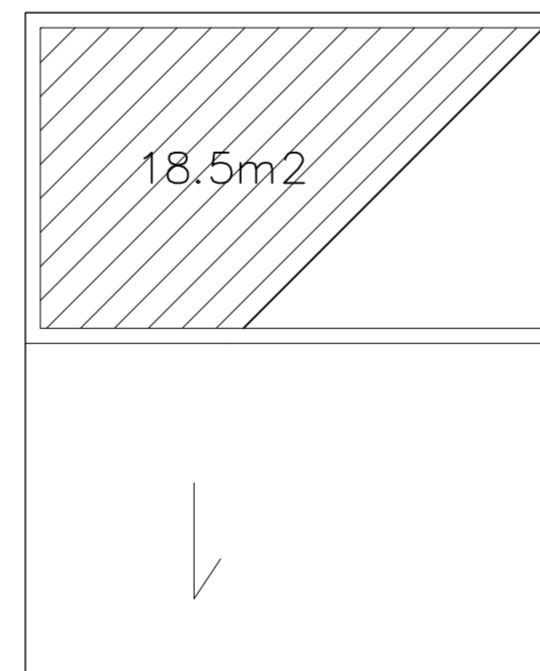

BUILDING STAGE TWO - REAR DORMER

MAIN ROOF TO BE EXTENDED TO THE REAR

REQUIRED DEMOLISHED ROOF AREA MEASURE AT ROOF PLAN 18.5m²

TOTAL REQUIRED DEMOLISHED ROOF AREA MEASURE AT ROOF PLAN
 $19m^2 + 18.5m^2 = 37.5m^2$ (61% OF EXISTING ROOF - REMAIN 39%)

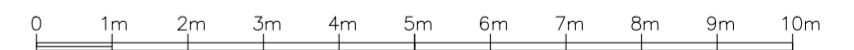

NOTE! THE MATERIALS USED IN THE CONSTRUCTION OF THE EXTENSION WILL BE OF SIMILAR APPEARANCE TO THOSE USED IN CONSTRUCTION OF THE EXTERIOR OF THE EXISTING DWELLINGHOUSE

STUDIO CAD PROJECTS
 Architectural Designers
 SCP
 TEL: 079 581 581 90
 E-mail: scprojects@onet.eu

PROJECT:
 78 LOWTHER ROAD
 LONDON SW13 9NW
 DEMOLISH ROOF CALCULATIONS

SCALE: 1:100 (A2) PROJECT No: 2240422-3 REV A
 DATE: APR 2024

THIS DRAWING MUST NOT BE REPRODUCED, COPIED OR SUBMITTED TO THE INSPECTION OF THIRD PARTIES WITHOUT OUR PRIOR PERMISSION. ALL DIMENSIONS TO BE CHECKED AND VERIFIED ON SITE.