

All aspects of this plan to be strictly adhered to

2x Cat C trees are to be removed (T's 3 & 4)

All other trees retained & protected

Access for works on the existing hard-standing.

No significant long-term impact to any retained trees is envisaged.

Protection measures will be put in place to safeguard the trees from any potential

indirect impact, such as fencing off the canopies and RPA's and the use of

temporary ground protection.

Fencing will create a Construction Exclusion Zone CEZ. No access for construction traffic or materials.

Existing boundary fencing will act a tree protection

Contractor's access on existing hard-standing at front of property

Site office/welfare outside any RPA

Unloading of materials away from retained trees onto existing hard-standing

No materials, mixing or washing out of tools within the RPA's

Washing out of tools and equipment not to be within 10m of any retained tree

All retained trees should be regularly monitored to assess health and potential issues

Arboriculturalist to visit site at regular intervals to check protection measures

Mitigation planting of 1x apple & 1x pear as shown

Common causes of Tree Death

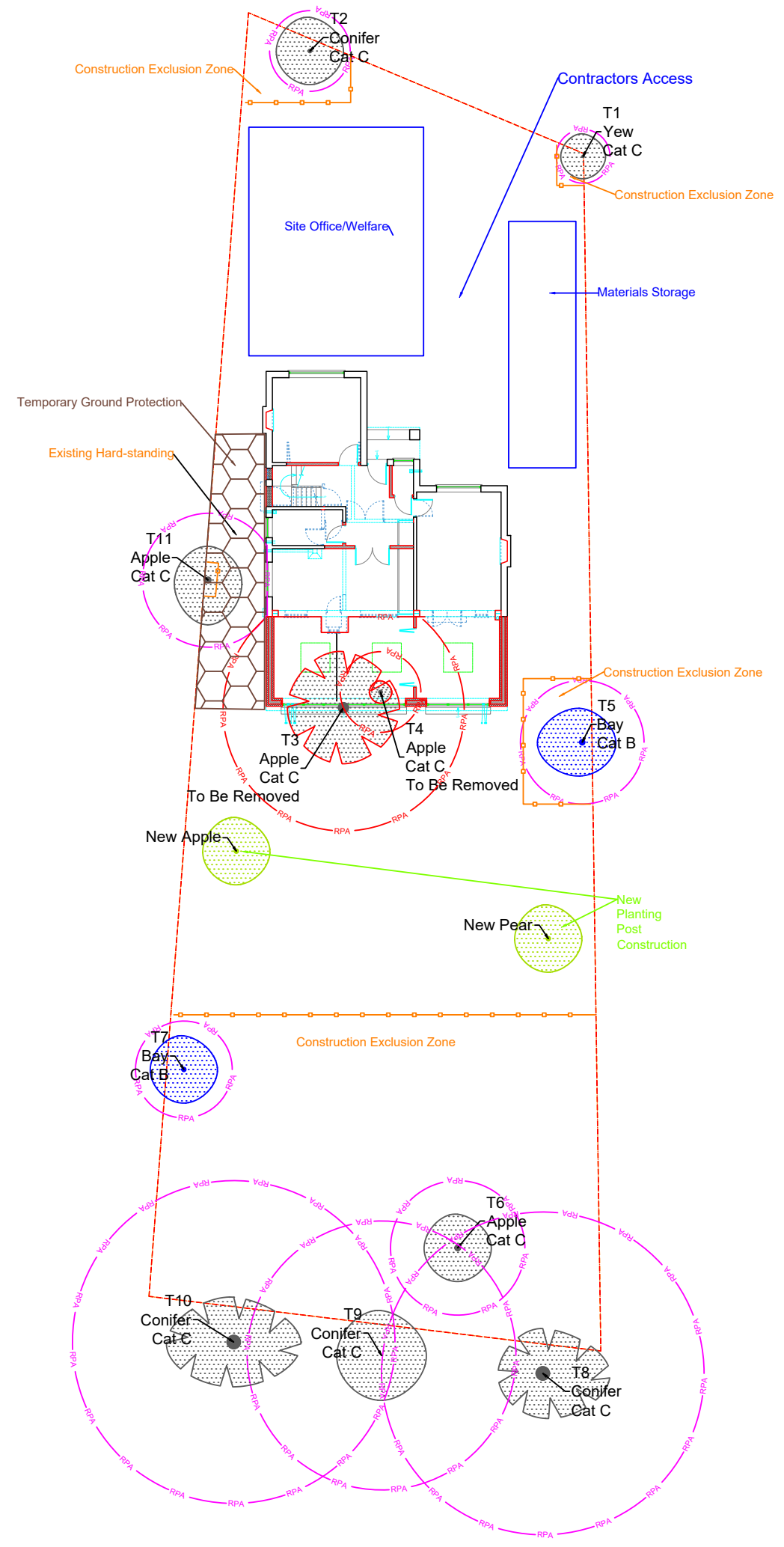
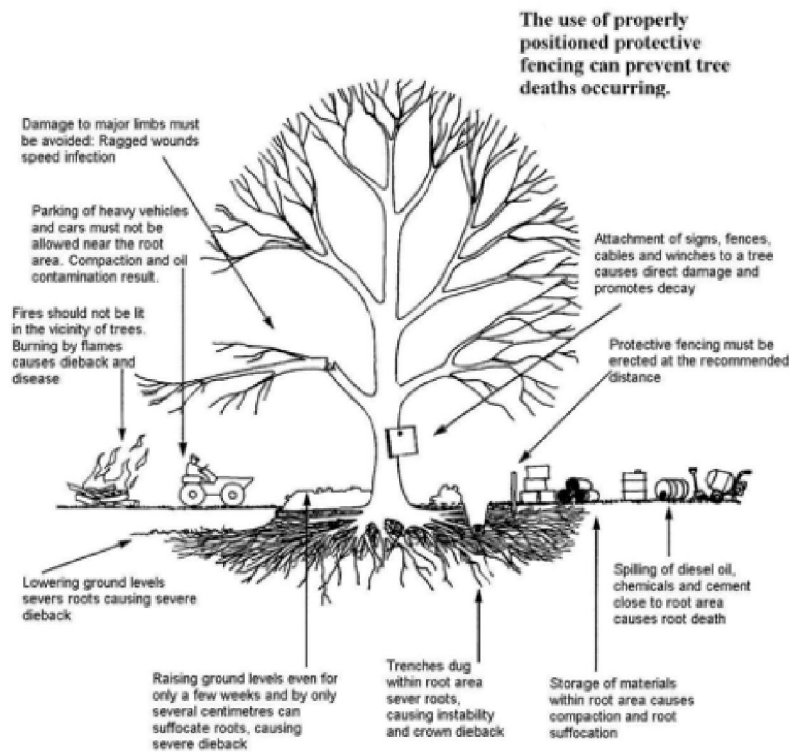

Temporary Ground Protection



Protective Fencing

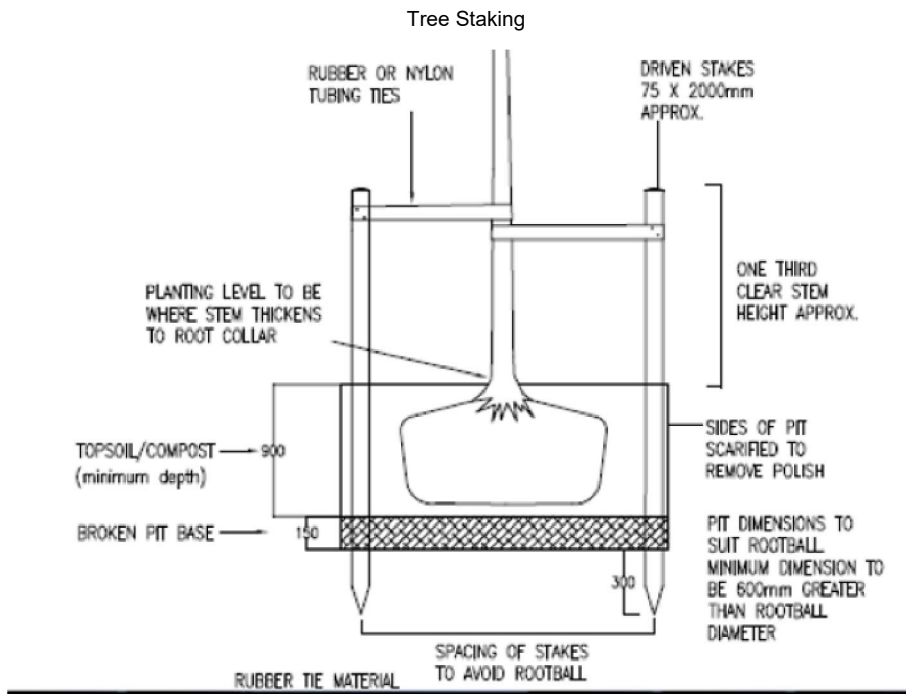
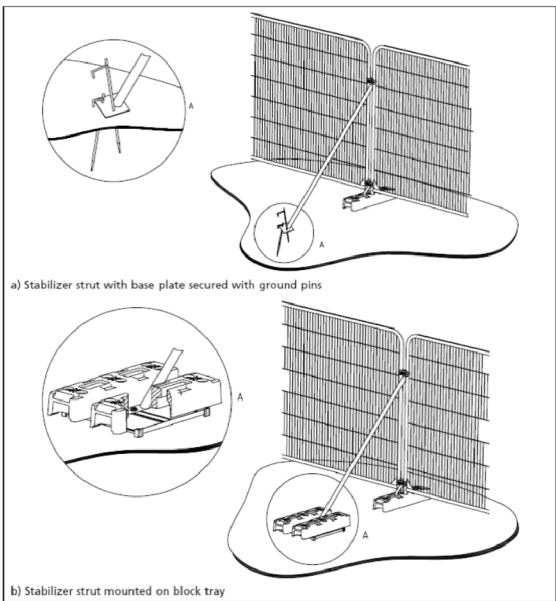

Signage



Tree Protection Plan showing surveyed trees & protection measures

Tree to be Retained

- Category A: Trees of high quality with an estimated remaining life expectancy of at least 40 years.
- Category B: Trees of moderate quality with an estimated remaining expectancy of at least 20 years.
- Category C: Trees of low quality with an estimated remaining life expectancy of at least 10 years, or a stem diameter below 150mm.

Tree to be Removed

- Category U: Trees in such a condition that they cannot realistically be retained as living trees in the context of the current land use for longer than 10 years.

- Protective Fencing/Hoarding
- 3D Geogrid Temporary/Permanent Hard-standing
- Contractors Access/Office/Material Storage



No.	Revision/Issue	Date
1		
2		

CENTRAL LONDON
TREE SURVEYS
ARBORICULTURAL CONSULTANTS
Celebrating 20 Yrs

info@central-londontreesurveys.com
Tel: 0800 6891746

Project Name and Address
**87 HANWORTH ROAD
HAMPTON TW12 3EA**

Project No 24141	Sheet 1 of 1
Date 2024-07-11 07:52:33	
Scale 1 to 200 at A3	