

**Detail A - Section through**  
As Existing, 1:10

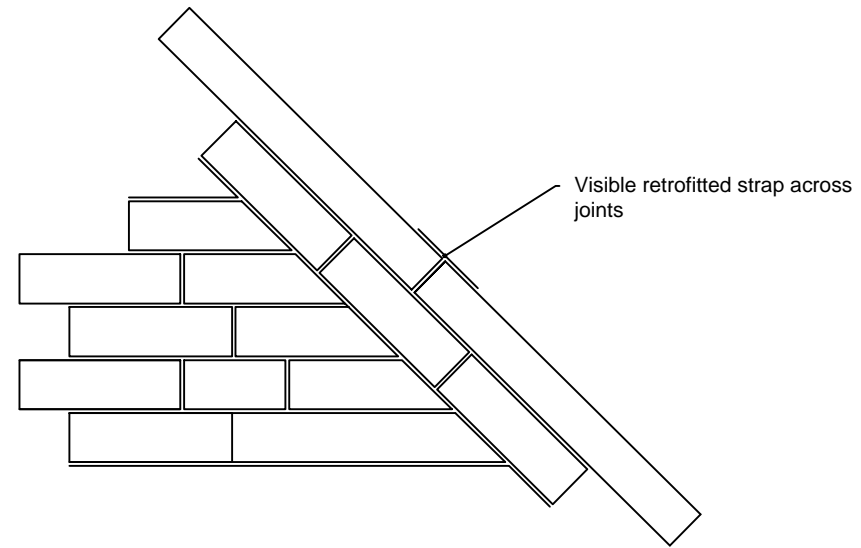

**Detail A - Outer elevation**  
As Existing, 1:10

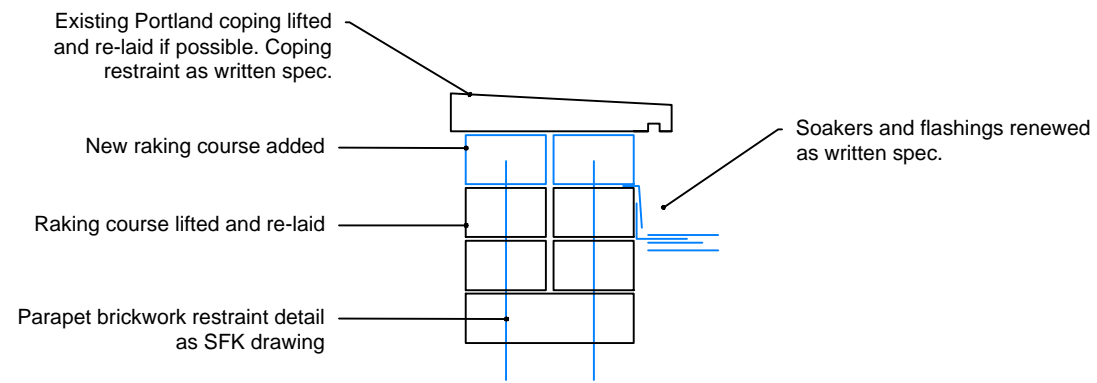

**Detail A - Section through and outer elevation**  
As Proposed, 1:10

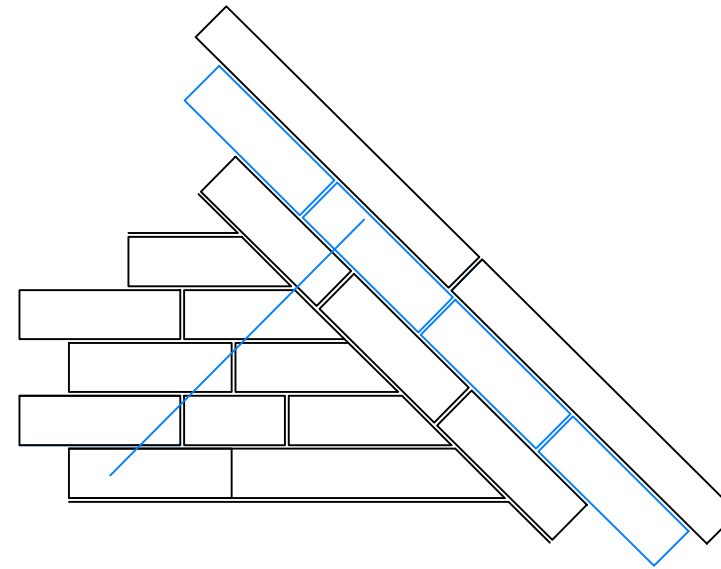

**Detail A - Outer elevation**  
As Proposed, 1:10

**GENERAL NOTES:**

1. Do not scale from this drawing. Use figured dimensions only. Contractor to check dimensions on site prior to construction and notify CA of any discrepancy.
2. This drawing is to be read in conjunction with all other relevant contract drawings, specifications & Schedules.
3. If in doubt: Ask
4. Martin Ashley Architects shall be notified in writing of any discrepancies.

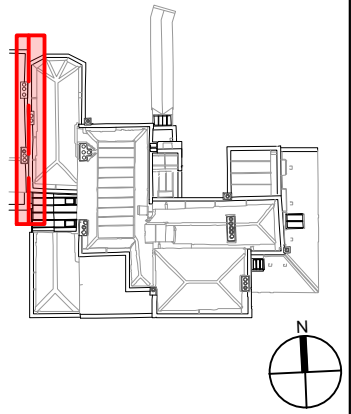

Rev.	Date.	Reason For Issue.	Chk.
-	19.08.24	First issue	GB

Status  
**Statutory Approval**

  
**MARTIN ASHLEY ARCHITECTS**  
745, 7th Floor, Regal House, 70 London Road, Twickenham, Middlesex, TW1 3QS  
T +44 (0) 20 8948 7788  
www.ma-arch.co.uk

Client  
Royal Botanic Gardens Kew  
. .

Project  
49 Kew Green, TW9 3AA  
Parapet and Flank Wall Repairs  
. .

Title  
Detail A  
Section through and outer elevation  
As Existing and as Proposed

Date	Scale
Aug 2024	1:10 @ A3
Checked By	Drawn By
GB	CO

Drawing Number	Revision
<b>2279-13/01/16</b>	-

