



Design and Access Statement

Homebase Hanworth

Overview

- This supporting design and access statement has been prepared by Gilmore Consultancy Ltd on behalf of Waves Consultancy Ltd. It accompanies a planning application for the installation of a hand car wash in the car park of Homebase Hanworth Twickenham Road, Twickenham, Feltham, TW13 6EZ.

Design

- Our proposal involves the installation of a concrete wash pad, erection of a canopy and stationing of a cabin. The proposal is functional in its design, and we do not believe it will be visually obtrusive due to its very limited size and height.

Transportation

- The proposed location has been selected after consideration was given to the provision of services (water, power and drainage) and a position that would minimise any impact on the customers wishing to visit the Store.
- The proposed layout is positioned to permit safe access across the car park for customers who can use the designated pedestrian walkways for access to the Store. We believe that the car park will have adequate capacity for this proposal, even at the busiest time of the year. We do not believe the proposed car wash will affect the egress/ingress routes of the car park and we do not think there will be any impact on local transport.

Retail Issues

- The introduction of the car wash will create new and sustainable economic growth in the area; it will have a positive impact on local employment creating an estimated four full-time and four part-time jobs. The car wash will also provide increased consumer choice with the addition of the service.
- The service will operate from twelve car parking spaces; the proposed use is ancillary to the retail use of the site. It is likely that the facility will be used in association with any trip to the store rather than resulting in a purpose-built trip. On Waves existing car wash sites in a similar setting (on average) approximately 89% of their customer base use the store or PFS, therefore we believe there will be no significant increase in traffic or car park usage associated with the car wash - please see transport assessment appendix 1. The car wash will employ a wash while you shop model, no queuing will be permitted customer will be directed to position cars on the wash pad if free, if not they will be asked to park up in any available parking space; whereby they can leave their vehicle with valeters and collect on return from shopping.
- 5-6 cars can be valeted at one time; therefore, the net loss of spaces is only 8-9. The design allows for both ambulant and disabled customers to either remain in their vehicles whilst it is washed (following which they will park their car closer to the store to go shopping) or leave said vehicle with valeters and collect upon return.

Residential Amenity

- Considering the existing background noise of the retail site, distance from residential dwellings and proximity to a busy road, it is unlikely that the installation will have a negative effect on residential amenity.
- All equipment used on our car wash will emit very low levels of noise and the jet washes are housed within the office to minimise any noise. Please see also attached noise survey showing the readings from the proposed equipment.

Environmental Compliance

- Every care is taken with the installation of a Waves car wash to ensure that the site is fully compliant with the EA's PPG13 & SEPA GPP13 guidelines. The wet wash area is built to a very high specification, we will install an impermeable concrete wash pad with centralised drain, silt trap and interceptor – please see page 4 for more information.
- The car wash operation will be environmentally friendly as possible, only using biodegradable detergents on our car wash.

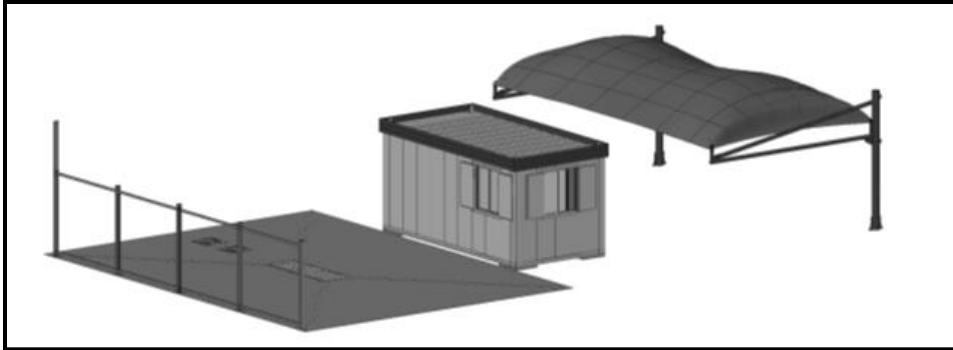

[Example image of HCW wet side](#)

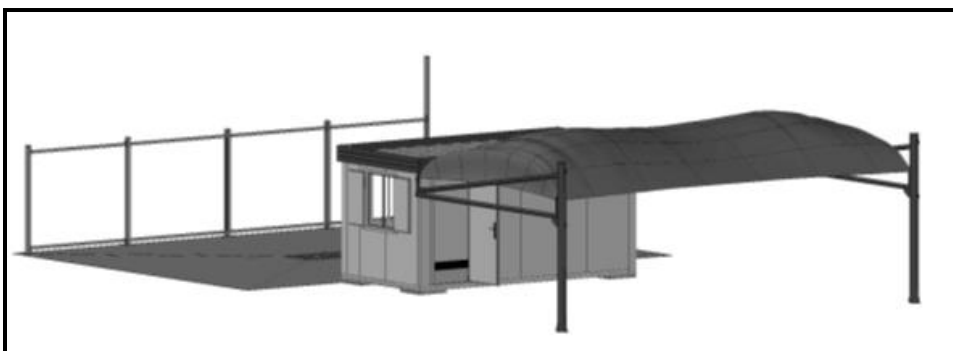

[Example image of HCW dry side](#)

Operational layout

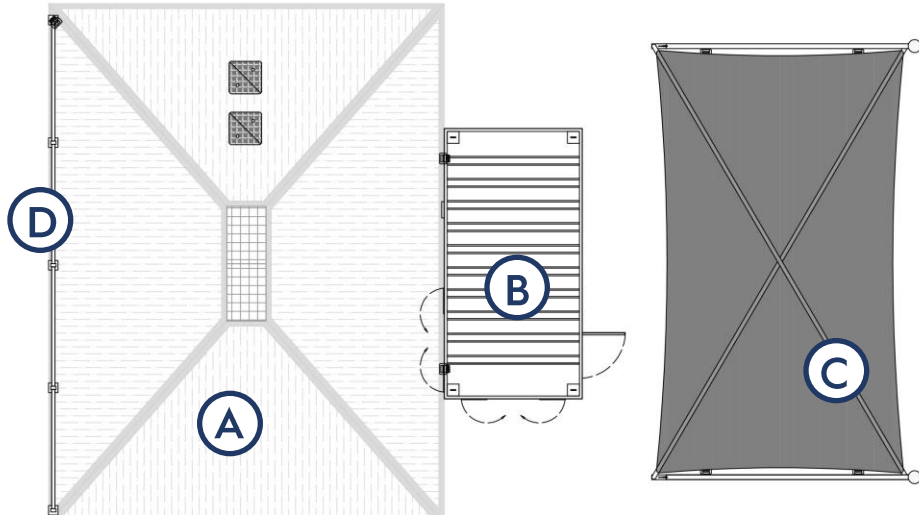

Example layout of hand car wash

Operation layout as below:

- A. Concrete wash pad to be installed with centralised drainage to same level as existing carpark hard standing (used as wet wash area).
- B. Bespoke anti-vandal cabin (used to house car wash equipment and take customer payments)
- C. Two post canopy with pvc cover
- D. Steel frame screens installed at wash pad rear (used to screen against spray and display advertisement).

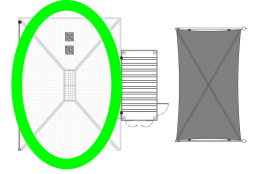

Wet wash area / concrete wash pad

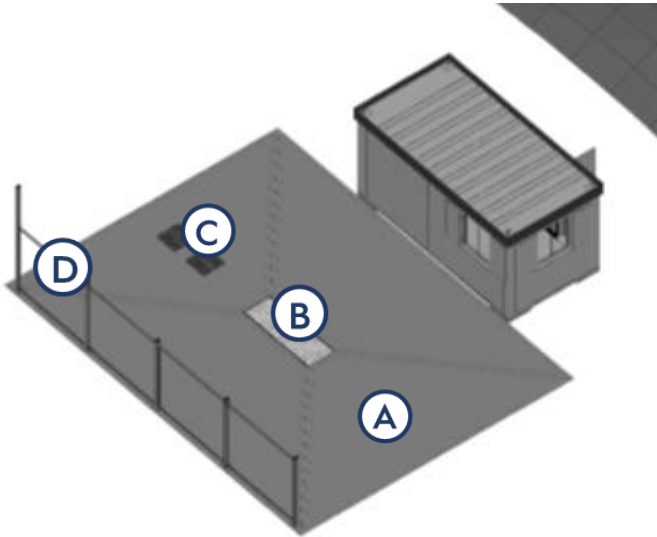

- A. Impermeable concrete wash pad, installed to same level as existing car park hardstanding with a gradient towards silt trap (water source connected to wash pad via the cabin).
- B. Silt trap positioned at lowest point identified on site used to collect solids from car wash effluent.
- C. Two chamber interceptor connected to silt trap water moves from silt trap to here to undergo two stage filtration before being pumped to foul manhole.
- D. Steel screen (approx. 2m high) used to shield against spray as well as holding car wash advertisement.

[Example image of wash area](#)

Concrete wash pad

- Every care is taken with the installation of a Waves car wash to ensure that the site is fully compliant with the EA's PPG13 and SEPA GPPI3 guidelines. We install a concrete wash pad with centralised drain, silt trap and interceptor.
- The concrete wash pad is divided into four areas to give the bow tie effect. The wash pad is slightly larger than the work area and is graded to ensure that all run off and spray is captured and directed into the silt trap located centrally.
- We also install a 2000 litre two (chamber) interceptor and silt separator to ensure that trade effluent discharge is minimal. The concrete is impermeable, and water cannot get into the surface water or groundwater system; only into our drainage system which is connected to the foul sewer. The collection tank will be sludge gulped as required by a licensed contractor and the waste disposed of as per EA and SEPA guidelines.
- We can operate a closed loop system however the treated water must be emptied and refreshed regularly to prevent stagnation - hence the requirement for a connection to the foul sewer. Please see Appendix 3 for further information on our drainage installation.

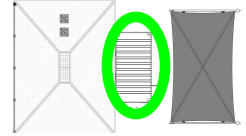

Cabin design



- Steel cabin (4.8 x 2.4m) painted. Partitioned internally with one side as a customer reception and the other as storage for detergents and equipment. Jet washes will be housed inside the cabin to reduce noise.
- Power, water and data will be supplied to the cabin.
- Signage to include mandatory health and safety, car wash menu and advertisements for service
- 2 x 50 watt polycarbonate floodlights to be installed on cabin roof facing the wet wash area.

Example image of cabin

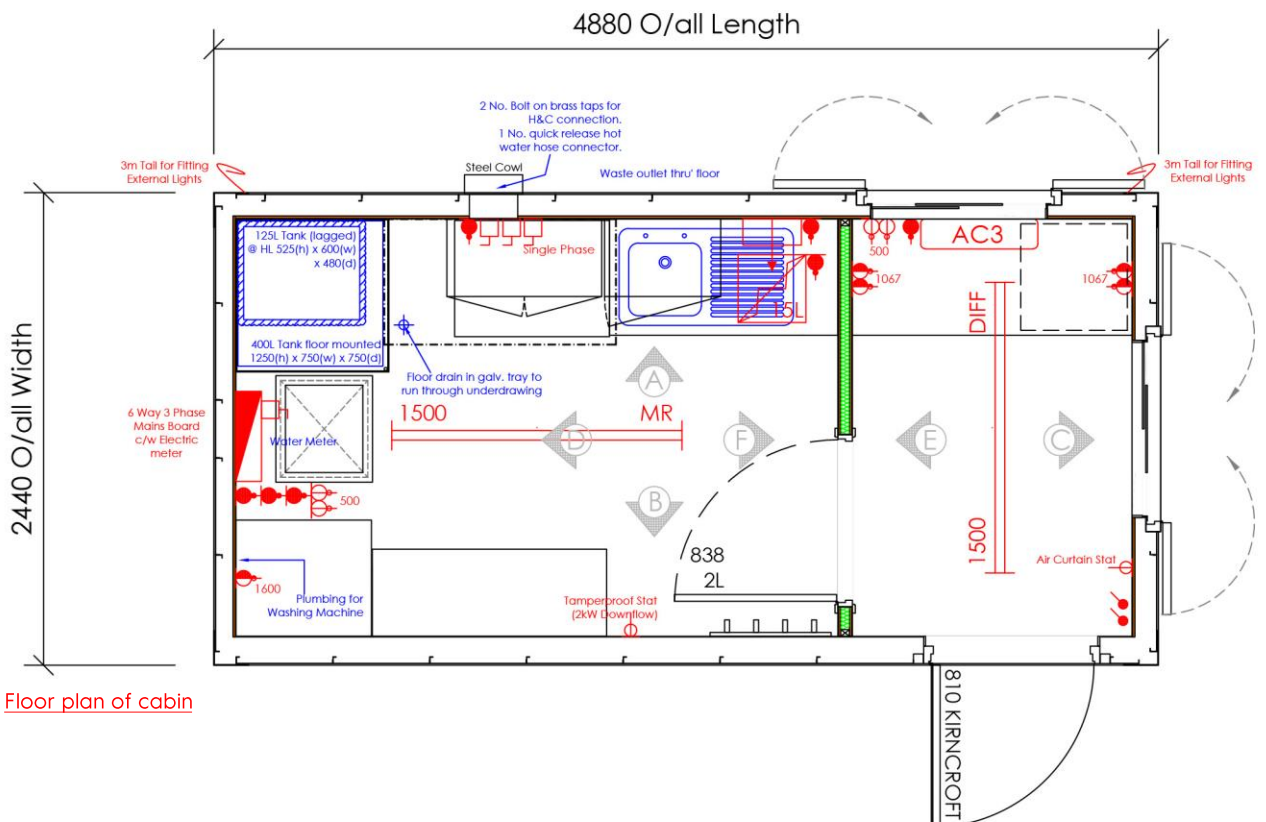

Floor plan of cabin

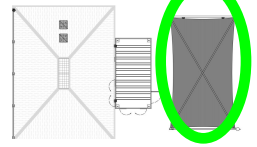

Dry valeting area and canopy



Installation of a two-legged cantilevered canopy over the dry valeting area, covering approximately four bays, as per the detailed specification below. 4 x150 watt polycarbonate floodlights installed under the canopy skin directed over the dry area (for details of the lighting, please see appendix 3)

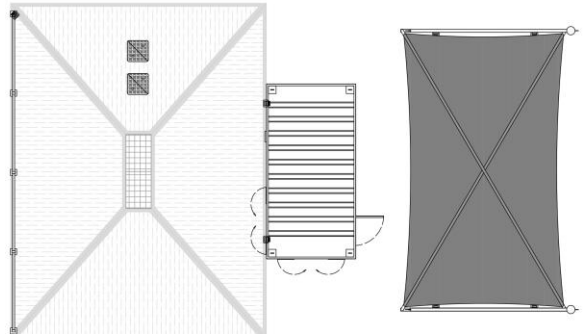

Example image of dry area canopy

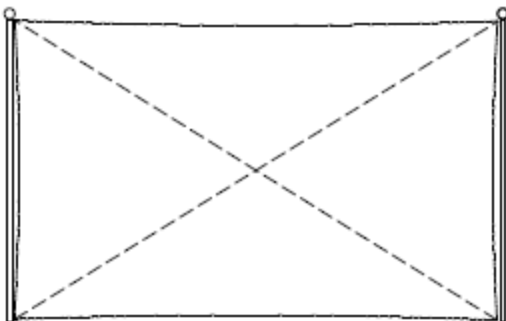
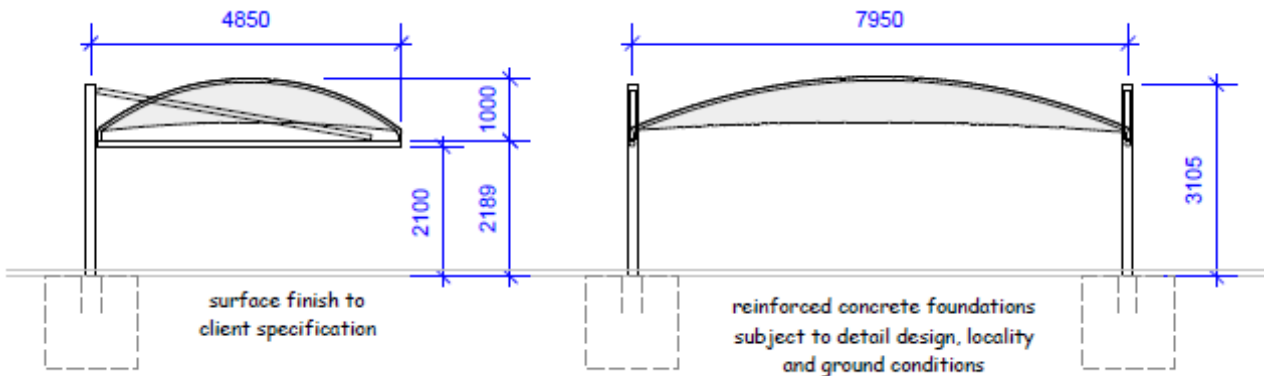

Tensile Characteristics of Fabric	
Base Fabric	Polyester HT1100 DTex
Coating	PVC
Finish	Biface
Fire Rating	M2 NFP 92.503/DIN 4102 B1/B0 5438
Colour Reference	5007 - Silver/Grey



All units on
 168mm dia. Galvanised Steel Support Posts
 &
 89mm dia. Galvanised Steel horizontal side/inclined brace members
 &
 60mm dia. Galvanised Steel Roof Arches
 Connection plates and bolts to manufacturer's details

ANPR Camera Pole

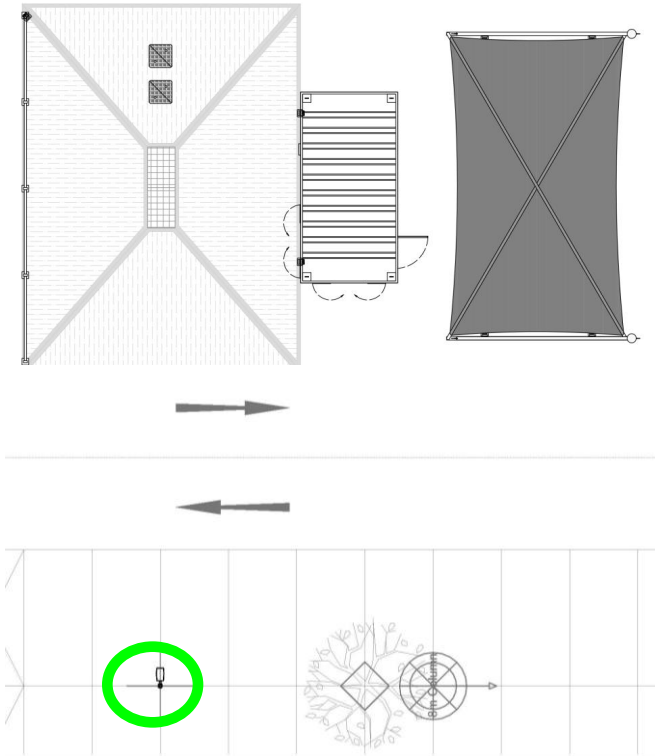

ANPR pole position

An ANPR camera will be installed on a 4m pole facing the wet wash area. The pole will usually be positioned in the centre of the opposite row of parking bays. The ANPR camera is part of a system of 7 cameras (1 ANPR & 6 CCTV) system. Please see document (ANPR setup) for more information.

As some of our car washes operate on a per car rent model. ANPR is used to confirm and check the number of cars washed monthly. The system is also used to prove monthly / yearly turnover to HMRC for tax purposes. To this end the ANPR camera is posed facing towards the wet wash area to capture customer licence plates.

The CCTV cameras are used to ensure security of the site and as a means of evidence to assist in any insurance claims.



Example image of ANPR pole

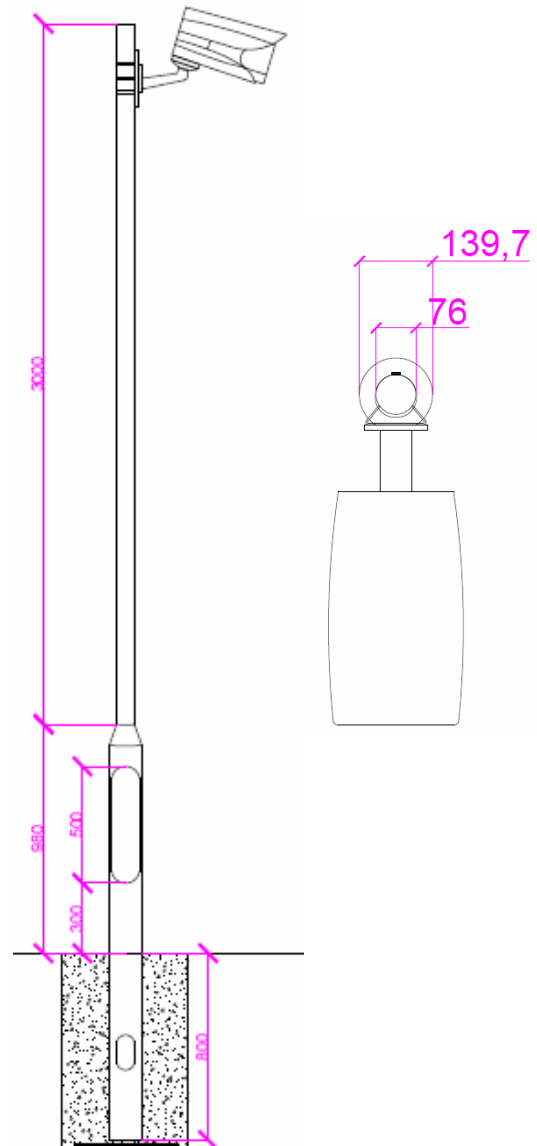

ANPR pole spec

ANPR Camera Pole

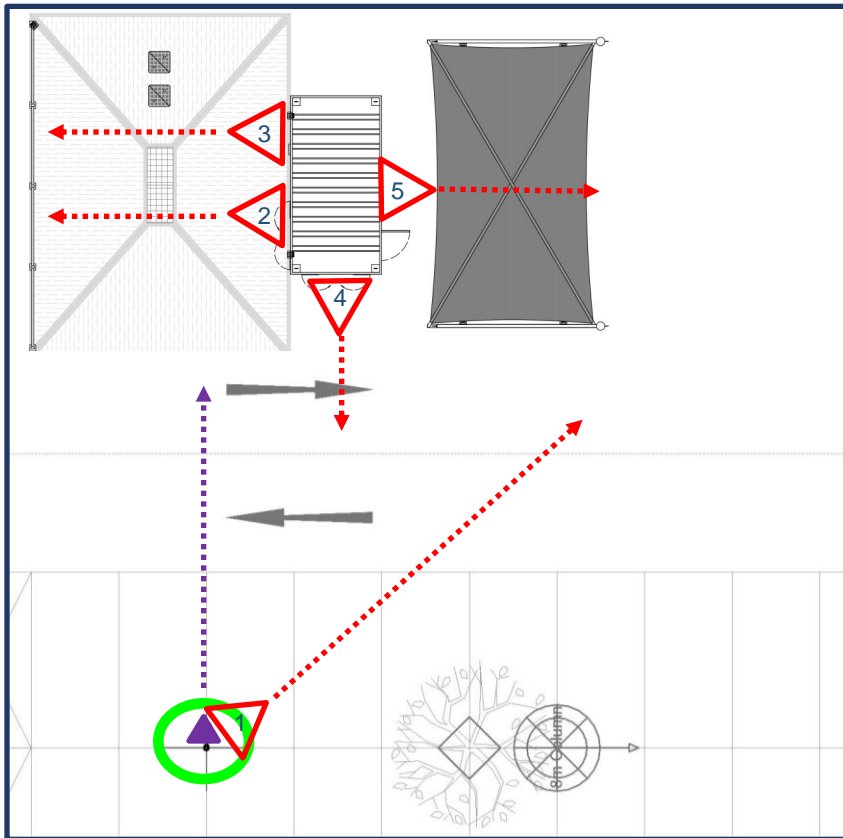

- ANPR pole position
- ANPR cam position
- CCTV cam position
- ANPR view
- CCTV view



ANPR cam



CCTV cam 1

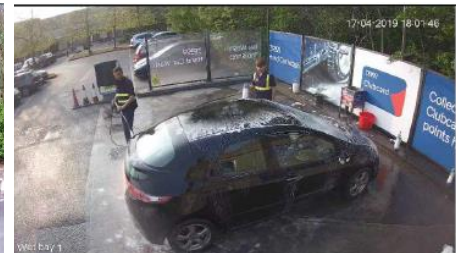

CCTV cam 2

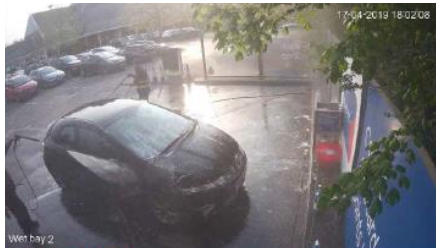

CCTV cam 3



CCTV cam 4



CCTV cam 5

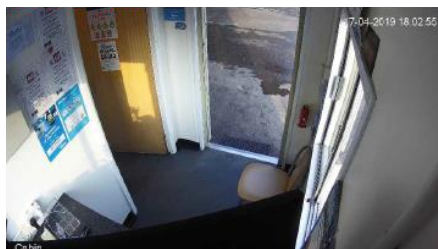

CCTV cam 6 (internal)

Signage - cabin

The cabin will have several fixed non illuminated dibond signs and two back lit light box signs as below.

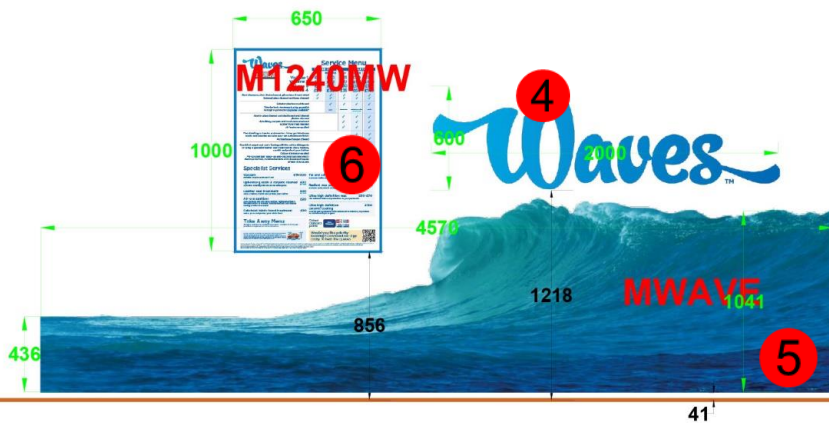

SIGN 1 - back lit light box sign, no background blue text fixed to cabin 1500mm (w) x 250mm (h) x 175mm (d), 2250mm from ground

SIGN 2 - dibond sign, white and blue background, blue and white text with multi-coloured images fixed to cabin 1950mm (w) x 900mm (h), 163mm from ground.

SIGN 3 - dibond sign white background blue text fixed to cabin 2500mm (w) x 250mm (h), 2216mm from ground

SIGN 4 - dibond sign blue text fixed to cabin 2000mm (w) x 600mm (h), 1218mm from ground.

SIGN 5 - dibond sign multi-blues image fixed to cabin 4570mm (w) x 1041mm (h), 41mm from ground.

SIGN 6 - dibond sign white background blue text fixed to cabin 650mm (w) x 1000mm (h), 856mm from ground.

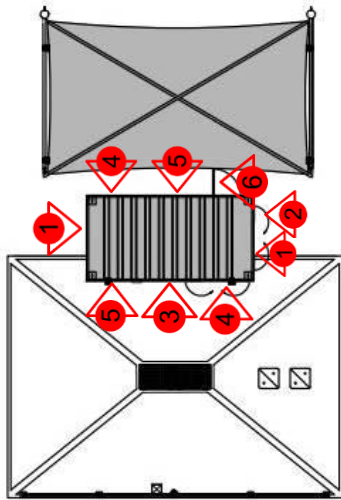

SCALE BAR 1:50



Signage – wet area

The installation will have free standing signs in the wet area. The signs will be a mix of double sided dibond and transparent Perspex. These will be fixed within galvanized steel frames that parameter the wet area. A set number of sign designs has been agreed with the landlord (as below) different combinations will be used depending on the amount of galvanized steel frames are required for an install, the number can vary depending on site conditions.

Signs 7-10 are all double sided dibond panels. Signs 11 – 12 are all single sided transparent Perspex panels.

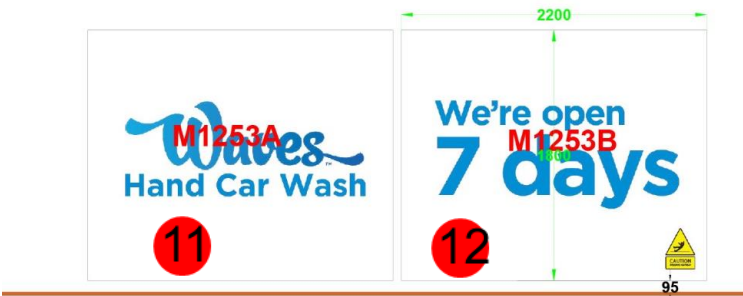
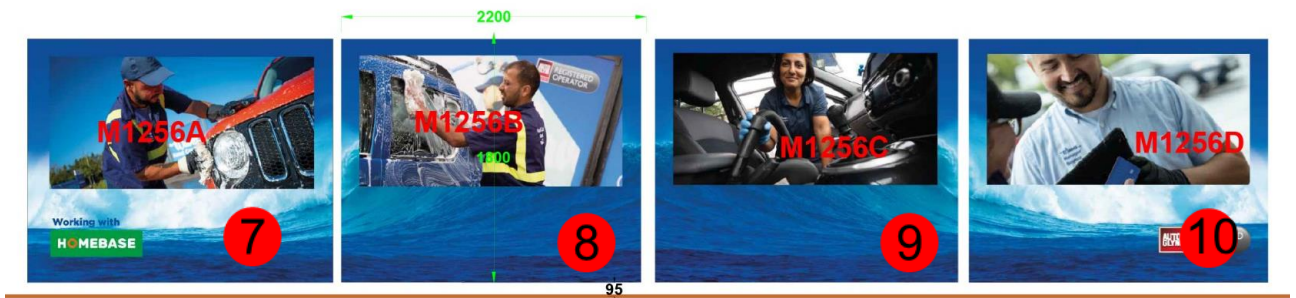

SIGN 7 - dibond sign multi-color image free standing in steel frame 2200mm (w) x 1800mm (h), 95mm from ground.

SIGN 8 - dibond sign multi-color image free standing in steel frame 2200mm (w) x 1800mm (h), 95mm from ground.

SIGN 9 - dibond sign multi-color image free standing in steel frame 2200mm (w) x 1800mm (h), 95mm from ground.

SIGN 10 - dibond sign multi-color image free standing in steel frame 2200mm (w) x 1800mm (h), 95mm from ground.

SIGN 11 - transparent perspex sign blue text free standing in steel frame 2200mm (w) x 1800mm (h), 95mm from ground.

SIGN 12 - transparent perspex sign blue text free standing in steel frame 2200mm (w) x 1800mm (h), 95mm from ground.

SCALE BAR 1:50



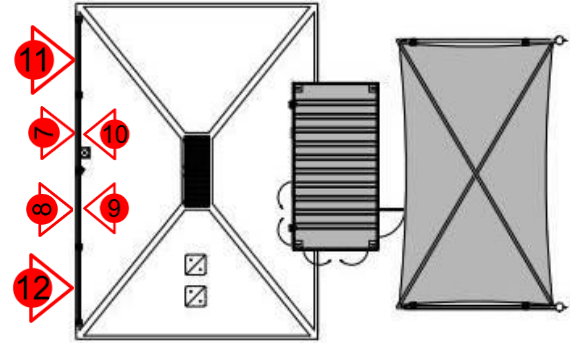

SCALE BAR 1:50

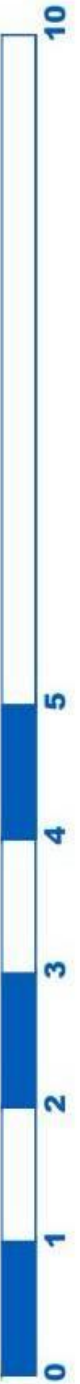

Appendices

Appendix 1 Transport Assessment

Appendix 2 Flood Risk Assessment (Flood Zone 2 or 3)

Appendix 3 Lighting Specification

Appendix 4 New Build Specification

Appendix 5 Fire Risk Assessment

Appendix 6 Emergency Spill Kit Instructions

Appendix 1 – Transport Assessment

Transport Assessment

The car wash is proposed to function as an ancillary service for the Homebase store and provide an additional service to Homebase customers. Although the removal of 12 spaces is proposed we can valet 5-6 car at once, making the net loss of spaces 8-9 lessening the impact on customer parking. Homebase store planning has reviewed the car park to ensure it can accommodate the loss.

Past surveys into car wash customers patterns on retail sites have found that the service will be used most of the time by an existing retail customer.

Basis research on commission by Waves Consultancy Ltd, using existing hand car wash installations on other retail sites (Tesco) has shown customer shopping patterns of car wash users and their reason for visiting a store. They interviewed 500 users of the car wash and 500 non-users across 10 different sites

- **Finding One:** questioning revealed that the majority of customers that used a car wash were a primary shopper at the store where they hand their car washed and almost all users were Clubcard holders.

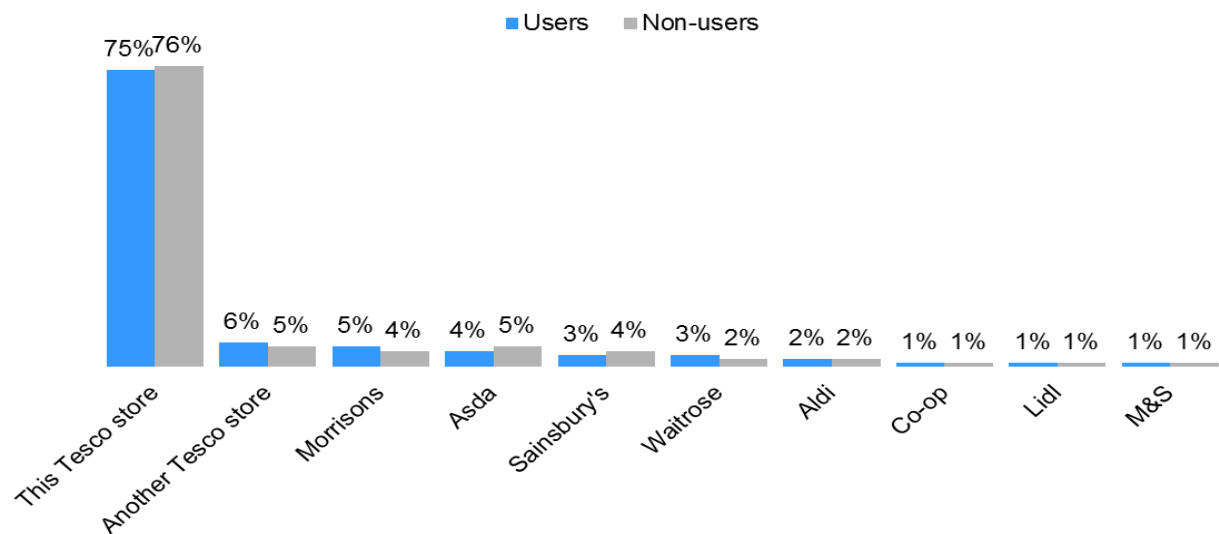

- QD3. Which one store do you use to buy most of your food and grocery shopping?
- Base: all respondents – Users (502). Non (215)

- Finding Two:** On average the car wash had 146 customers over a week. Data was taken from a cross section of car washes across the Tesco estate, 13 sites over a six month period, showing how many cars each site washes each week. From the data it was found the busiest sites on average washed 192 car per week and the least busy 96 cars per week.

Classification	County	Spaces	February				March				April				May				June				July				Average	
Extra	Middlesex	587	159	211	238	210	171	136	129	207	230	125	127	127	178	117	136	148	151	218	134	147	197	246	254	261	177	177
Extra	Gwynedd	590	137	166	173	322	207	185	153	307	358	179	113	166	179	99	149	162	133	202	157	139	139	194	204	221	208	186
Extra	Dorset	535	89	104	115	133	88	81	94	103	85	107	99	89	77	73	61	99	88	126	65	122	111	130	165	153	134	104
Superstore	Essex	240	86	91	102	87	65	57	94	264	391	269	212	220	233	136	127	131	168	220	151	105	165	190	229	255	129	167
Superstore	N. Yorkshire	401	109	100	118	119	76	82	89	99	123	82	85	93	97	76	67	91	90	106	95	90	91	101	115	112	97	96
Extra	W. Yorkshire	531	67	73	90	103	84	89	34	117	130	107	65	87	109	89	86	94	83	105	106	117	98	130	134	132	136	99
Extra	Tyne & Wear	998	117	123	98	169	84	158	77	131	150	146	119	84	116	103	81	74	81	116	92	92	82	104	124	107	129	110
Extra	Greater London	484	99	91	109	135	88	80	77	136	131	95	124	114	96	100	93	126	118	122	106	109	142	158	135	136	110	113
Extra	Greater London	632	174	115	165	89	90	96	60	132	102	97	93	107	144	97	98	83	92	130	85	94	172	194	182	181	183	122
Superstore	Gloucestershire	234	121	101	112	173	103	74	39	96	180	72	118	119	98	56	89	109	96	167	107	107	146	208	222	247	145	124
Superstore	Norfolk	533	264	344	306	332	223	230	155	257	292	267	223	264	229	208	200	168	230	211	188	198	262	250	263	243	216	241
Extra	Hertfordshire	1006	172	155	206	168	183	172	142	210	303	214	226	229	240	171	163	233	189	218	135	131	158	153	218	257	143	192
Extra	N. Wales	677	128	185	180	299	138	172	72	143	286	147	141	103	110	87	102	144	129	190	106	165	151	294	231	184	178	163
																												146

- Finding Three:** Only 11% of customers visited the retailer solely to use the car wash

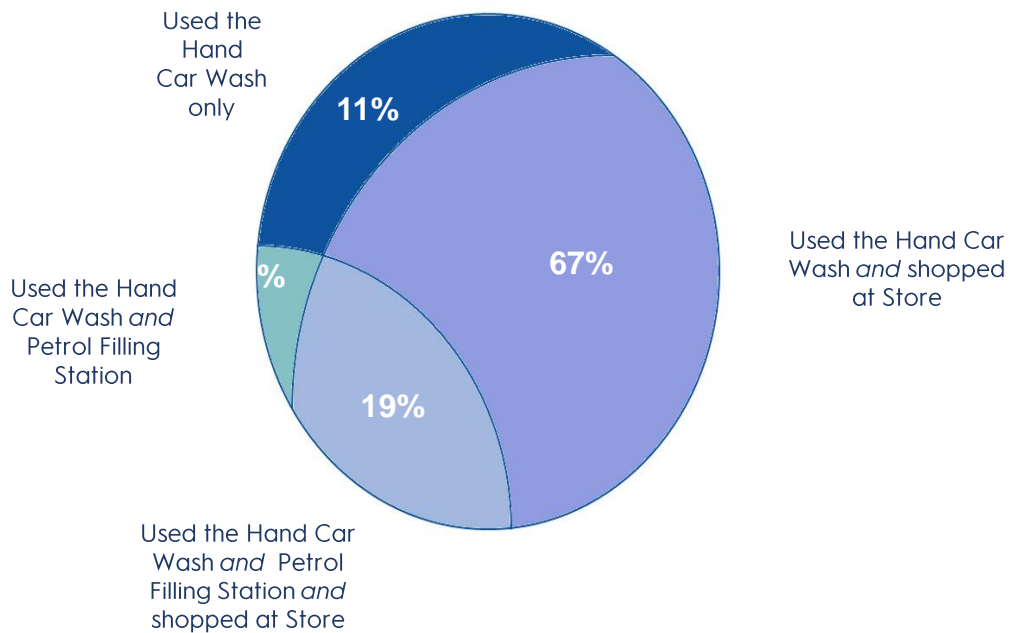

- Q4B. Did you use, or plan to use, any of the following today? Hand car wash only / hand car wash and shopped at Tesco / Hand car wash and Petrol Filling Station / Hand car wash and Petrol Filling Station and shopped at Tesco
- Base: all users (n=502)

Summary: Based on the above data from a similar retailer we can conclude that if only 11% of customers came solely to use the hand car wash then a car wash on a retail site is likely to generate a small amount of vehicle movement to the car park per week.

In addition to this we would operate a wash while you shop operating model and are fully insured to drive all customer vehicles, we would not allow our customers to form queues in the car park and customers waiting for the car wash would be directed into a parking bay by valeters until the work area was free.

Therefore, we believe that the impact on vehicle movements to and from the car park would be negligible and the impact on the movement to traffic around the car park would not be significantly altered by the hand car wash installation.

Appendix 2 – Flood Risk Assessment (Flood Zone 2 or 3)

Flood Risk Assessment – Hand Car Wash Development in Flood Zone 2 or 3

Following consultation with Gemma Harrison (Flood & Coastal Risk Management Officer, Environment Agency) regarding a previous, identical application, she has advised that given the size of the development (approx. 105m²), a flood risk assessment of approximately one page would be adequate, including the plan for the disposal of the polluted water in preparation of a flood at the site to prevent pollution, and the emergency plan for closure during a flood event.

Flood Risk Assessment for the Proposed Hand Car Wash

It is considered that the flood risk for the hand car wash is low because there is only one small property proposed and this is not residential. If there is a flood risk warning, the car wash will be prepared as follows:

Cabin

The EA advised that there are no restrictions with regards to floor levels for the proposed office and store however we will raise the cabin slightly so that it is above the flood level. We will implement some basic resistance and resilience measures as follows:

- When the doors and windows are closed on the cabin, water cannot get into the cabin, except by coming up through the floor
- When building the car wash, we will use triple core armoured cabling for all connections to the cabin so that there is no danger of damage from any flooding
- We install shelving into our cabins that we can remove any items from the floor and put them on the shelves as required if we know there is a flood imminent
- All electrical sockets, fuse boxes, controls and wiring will be above flood level

Concrete wash pad

Every care is taken with the installation of a Waves car wash to ensure that the site is fully compliant with the EA's PPG13 guidelines. The wet wash area is built to a very high specification and we will install an impermeable concrete wash pad with centralised drain, silt trap and interceptor – please see page 4 of the design and access statement for more information.

The concrete is impermeable and water cannot get into the surface water or groundwater system; only into our drainage system which is connected to the foul sewer. The collection tank will be sludge gulped as required by a licensed contractor and the waste disposed of as per EA guidelines.

We can operate a closed loop system however the treated water must be emptied and refreshed regularly to prevent stagnation – hence the requirement for a connection to the foul sewer.

If there is a flood risk warning then we would ensure the connection is opened to the foul sewer, this would ensure that water would flow freely through our drainage system and into the foul sewer to ensure that there was no back up of polluted water from the interceptors – this could only happen if we were operating the closed loop system.

The operator will be made fully aware of this FRA and we will have a copy on site at all times.

Appendix 3 – Lighting Specification

Proposed lighting for hand car wash

Carina LED Polycarbonate Floodlight 50W LED Black

Product Datasheet



Description

Compact and economic polycarbonate LED floodlight, Cool white, 50W LED exceeds performance of 70W HQI, Polished faceted reflector, and textured glass for optimum performance, Pre-wired with 1 metre of, rubber insulated cable for ease of installation, 30,000 hours average lifetime, Non-dimmable, Supplied c/w Integral Driver.



Code	Description	Lamp
ACALED50	50W Cool White	LED



LED Information

Lumens Delivered	30W	50W
Cool White	2335	4099
Warm White	2036	3714
Lm/W Cool White	86	91
Lm/W Warm White	75	80
CRI	Ra 70	
CCT	4000K	
	3000K	
Input	240V	

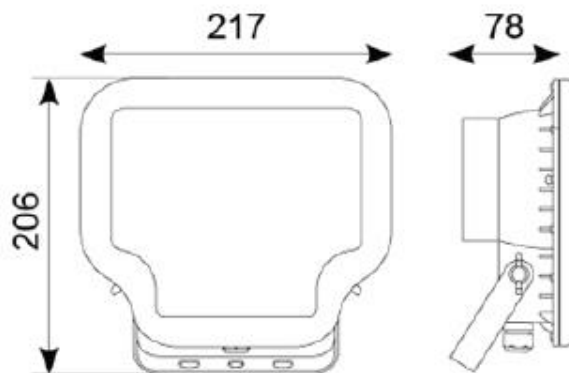

Proposed lighting for hand car wash

NVC Lighting Ltd - NTA70HQIDE – Luminaire Data



Luminaire data

NVC Lighting Ltd, NTA70HQI-DE-740 (NTA70HQI-DE-740).
 LDC

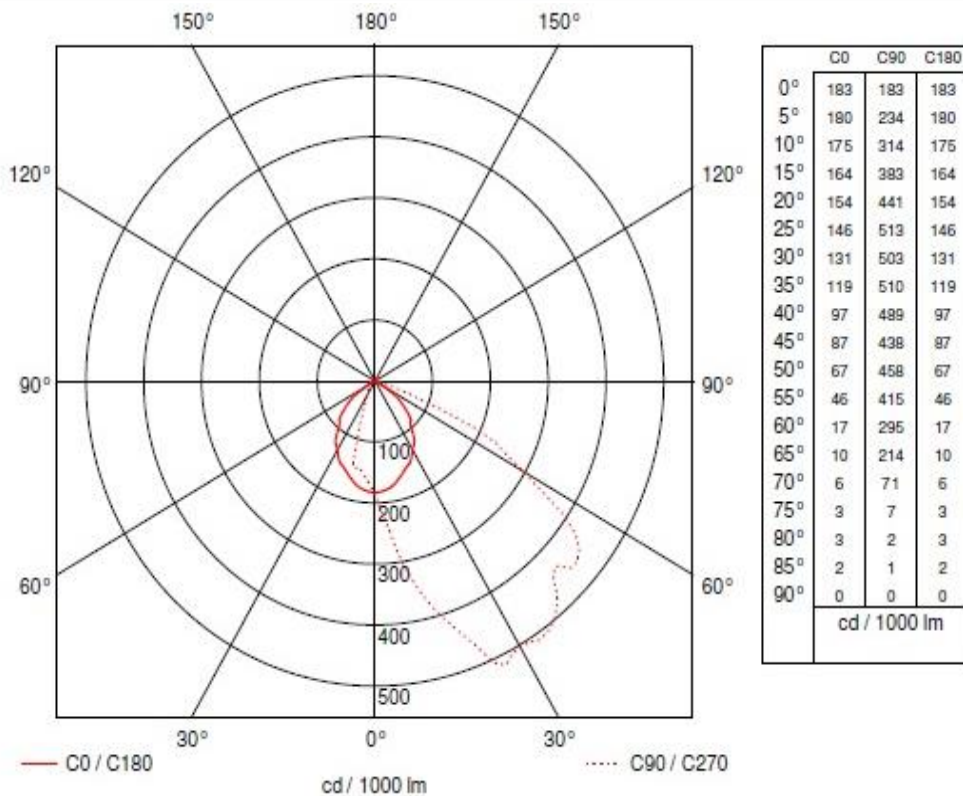

Manufacturer	: NVC Lighting Ltd	Efficiency factor	: 70.1% (A40)
Order number	: NTA70HQI-DE-740	Light distribution	: asymmetric
Luminaire name	: NTA70HQI-DE-740	Beam Angle	: - C0
Equipment	: 1 x 70w ARC70/UVC/TD/742 0 W / 5		: 62.1° C90
Dimensions	: L 230 mm x W 350 mm x H 85 mm		: - C180
File name	: NTA70HQI-DE-740.Idt		: - C270

Floodlight Locations

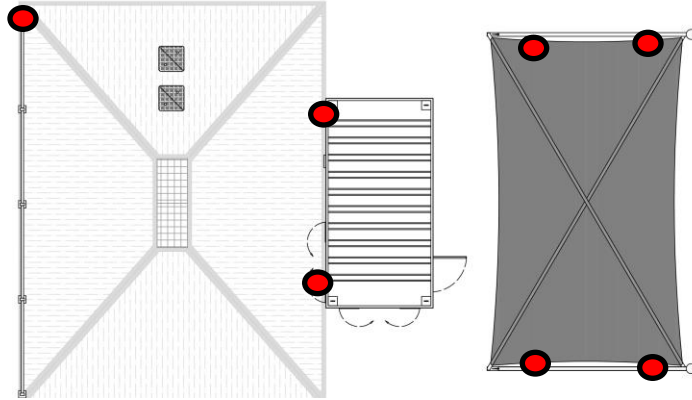

PLAN VIEW

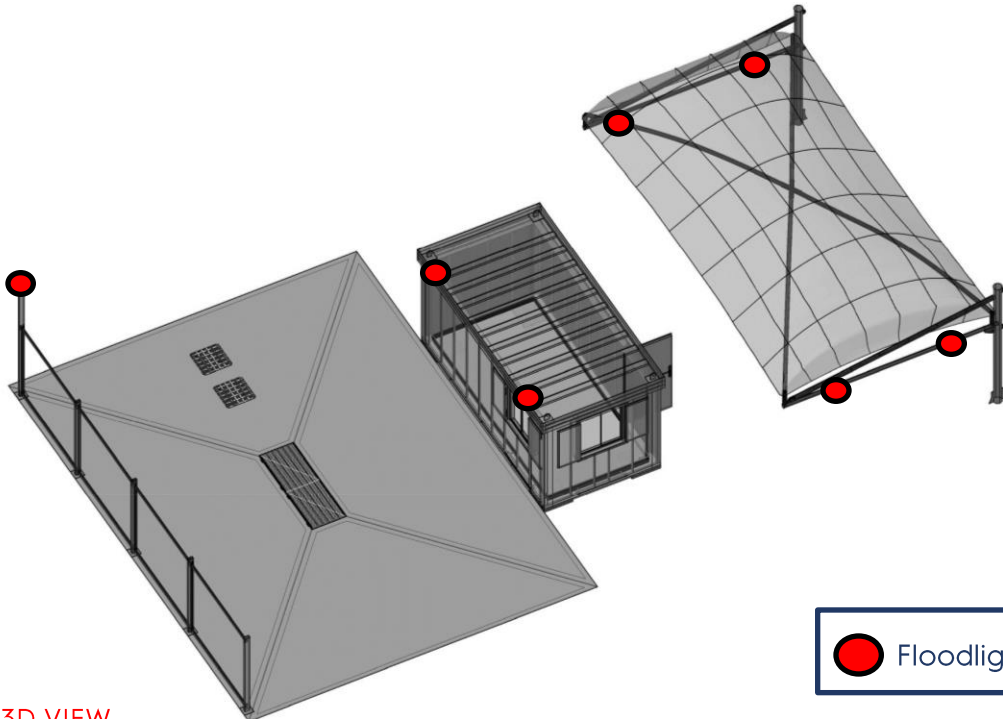

HCW 3D VIEW

Waves will install 7 x 50 watt polycarbonate floodlights –

- 2 on the roof of the cabin angled down towards wash pad.
- 1 on a pole above the screens angled down towards wash pad.
- 4 under the canopy cover angled down towards hard standing.

The floodlights are approximately 200mm x 200mm square., all floodlights are directed down over the work area and are not illuminated when the site is closed. .

Appendix 4 – New Build Specification

Build specification

INTERCEPTOR

- 1) The contractor shall allow for the supply of the 2000 litre two (chamber) interceptor and silt separator and installed to installation details contained in Data Sheet, which is supplied with the unit.
- 2) The invert of the separator inlet shall be such so as to ensure a fall of not less than 1.6% (1/60) from the discharge invert of the silt trap discharge point.
- 3) The separator shall be seated and surrounded in suitable concrete as detailed in accordance with the supplied data sheet.
- 4) The contractor shall allow for the supply and installation of 2no 600 x 600 38T Heavy duty Manhole Covers and heavy-duty frames.
- 5) The separator access chambers should be linked by a 150mm duct between each chamber and each chamber should have a 150mm duct running back to the main service chamber that is located under the rear of the cabin.
- 6) The frames shall be seated on formed foundations and necessary engineering brickwork and shall be pointed in all exposed areas. Care shall be taken so as not to allow any load from traffic onto the interceptor.

SILT TRAP

- 1) The contractors shall supply and install a hinged lid silt trap. This should be installed in the centre of the wet area. The top of the silt trap should be 50mm lower than the lowest point of the wash area and installed to manufacturers specifications. The silt trap shall be installed as per the detail shown on the general arrangement drawing.
- 2) The silt trap shall be connected to the separator by a 100mm drainage pipe laid to falls of not less than 1:60. If a gully is needed it shall be connected to the separator by a 100mm drainage pipe laid to falls of not less than 1:50.

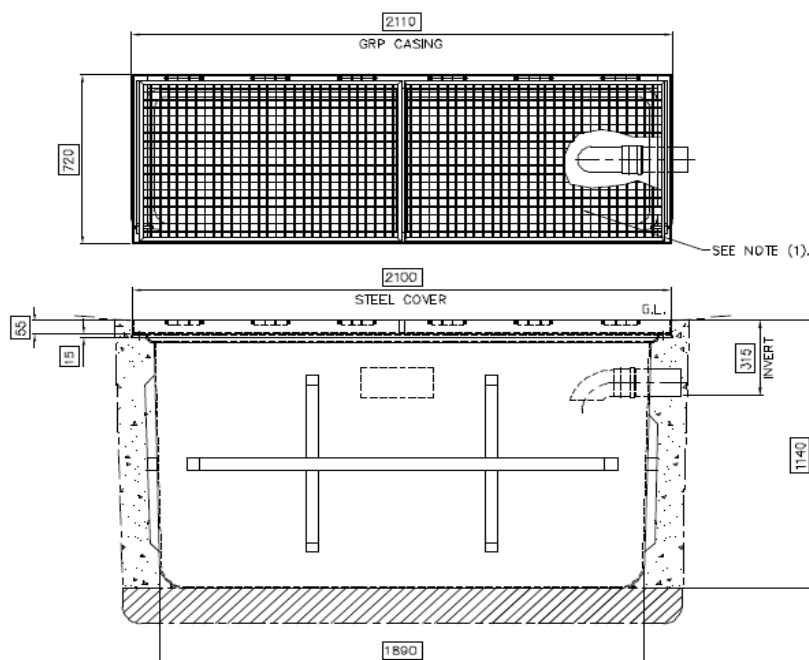

CONCRETE PAD

- 1) The size of the concrete wash bay pad should be four bays wide and between 6.5 meters deep from front of kerb-line and a thickness of 200mm.
- 2) This should be divided into four areas to give the bow tie effect, with the silt trap located centrally (subject to site survey).
- 3) The slabs should have two layers of reinforcement mesh (a142 mesh). The minimum concrete quality C35 WRA. This should have a brush finish with 100mm trowelling around the outside of each section. (See below)



PATHWAY

- 1) A concrete walkway is to be installed along the back of the car wash area; this shall be 160mm thick and vary in depth depending on site max depth to be 1.8m. This should have a brush finish and 100mm trowelling around the outside edge.
- 2) A 300 x 300 access chamber and lid is to be placed at the far side of the wet area concrete walkway. This should be fed by 100mm duct running back to the service manhole that is underneath the cabin.

FOUL DISCHARGE SERVICE SUPPLY

- 1) The contractor shall supply and install in 100mm ducts as shown on the drawing in 32mm MDPE BLACK pipe as a discharge main from the interceptor discharge pump. There should be NO joints to the pipe apart from in the manholes or service rooms the connections should only be compression and NOT push fit with pipe inserts used.
- 2) The discharge pipe shall terminate within the identified foul manhole. The pipe shall where possible be benched onto the existing benching so as to ensure the directional flow is with the fall of existing sewer. In the event that this is not possible (e.g. deep manholes) the pipe shall be secured to the side of the manhole so as to direct the flow vertically down on the opposite side of any entry point.
- 3) The discharge pipe shall be connected to the supplied pump by a galvanized chain and fixed to the wall of chamber by an eye type anchor bolt within the interceptor so as to allow easy removal of the pump should it be required. This should be by the use of cam lever couplings – see diagrams below
- 4) All pumps that are required will be supplied by Gilmore Consultancy.

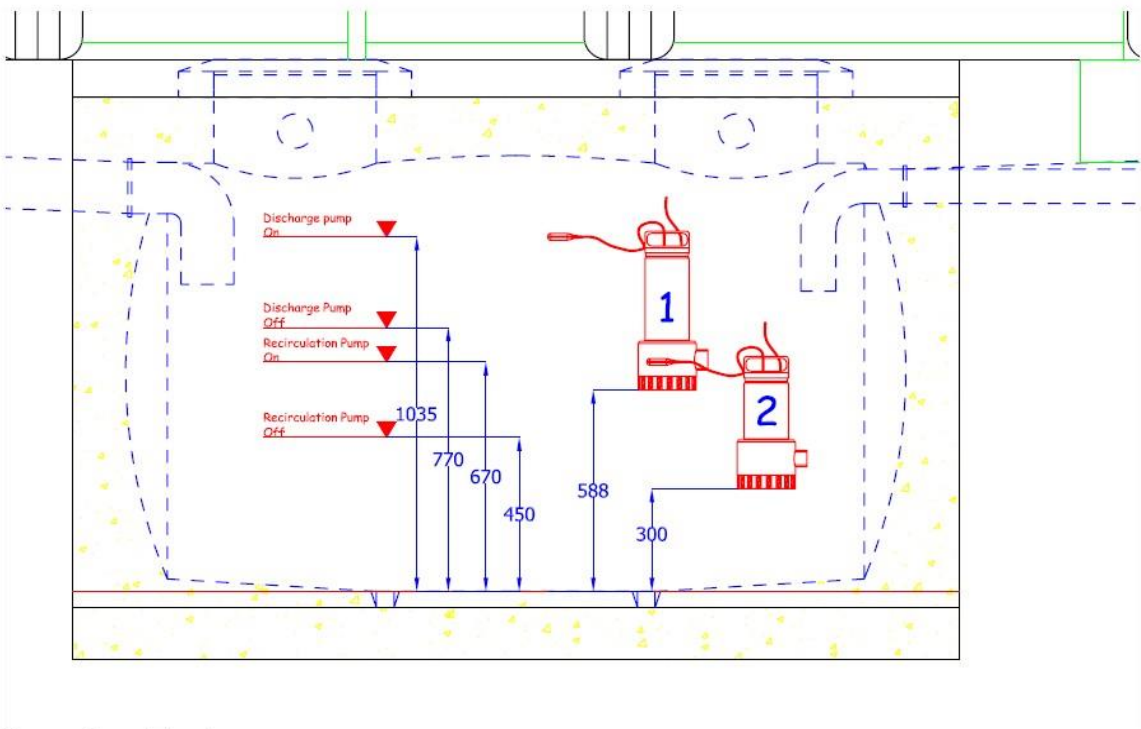
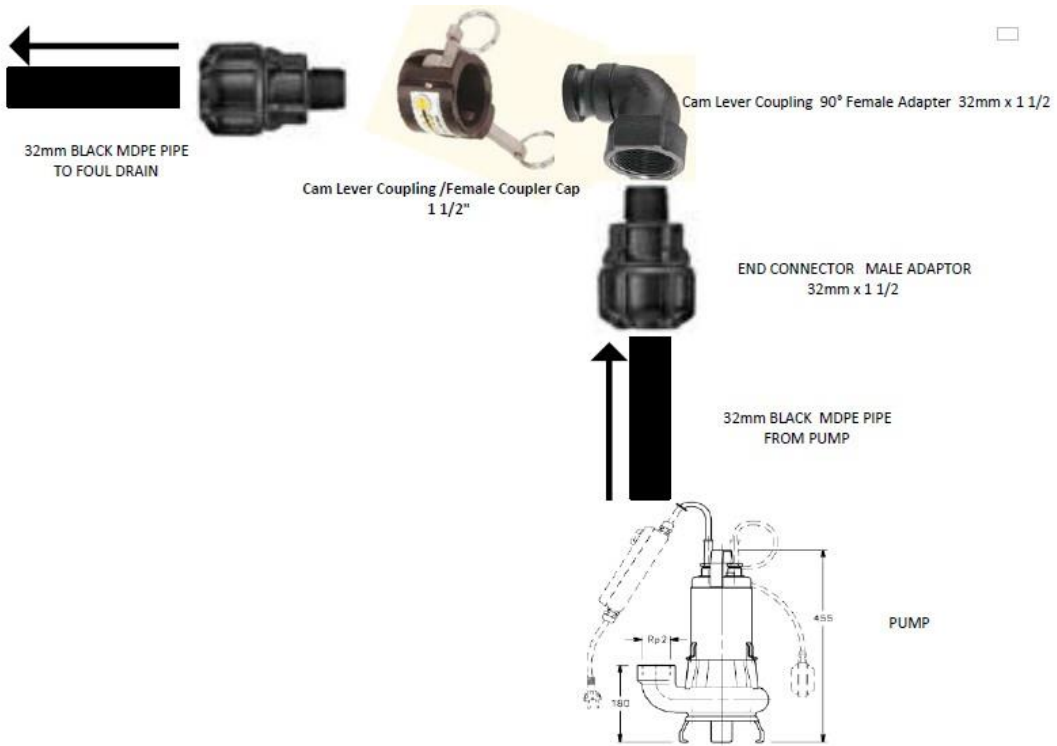

Pump 1 - Discharge pump

Lowara Domo 7VX 220/240V single phase 0.55 KW complete with "Vertex" Impeller to pump entrained solids.

Connection - 1½ " BSP female thread connected to a 50mm Black MDPE pipe. Note - ensure suitable coupling is installed within the discharge line to allow complete removal of pump if required.

Trench Type A From Duct Chamber to Cabin

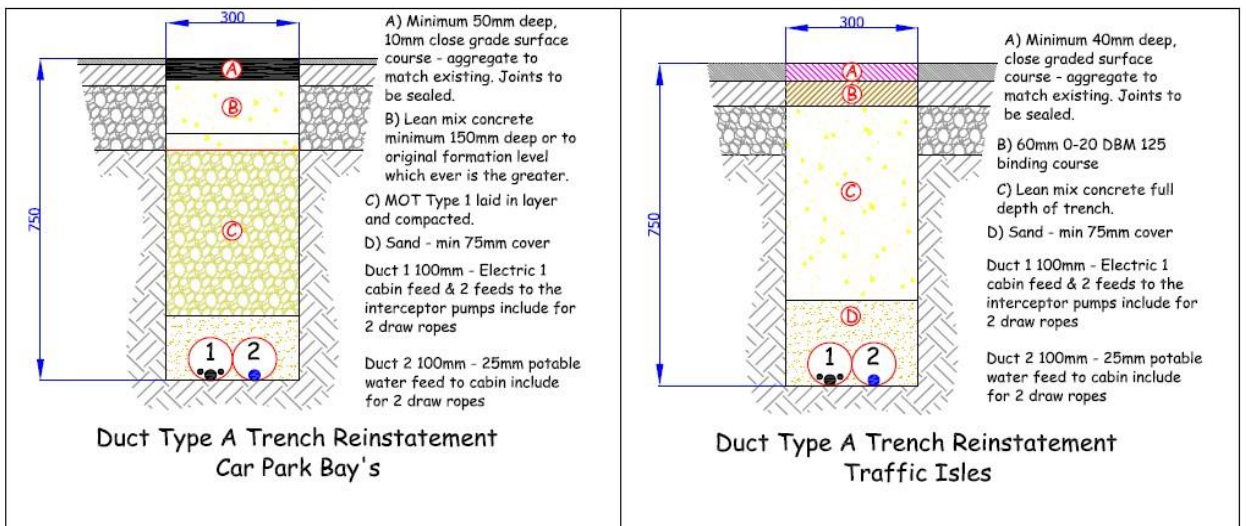
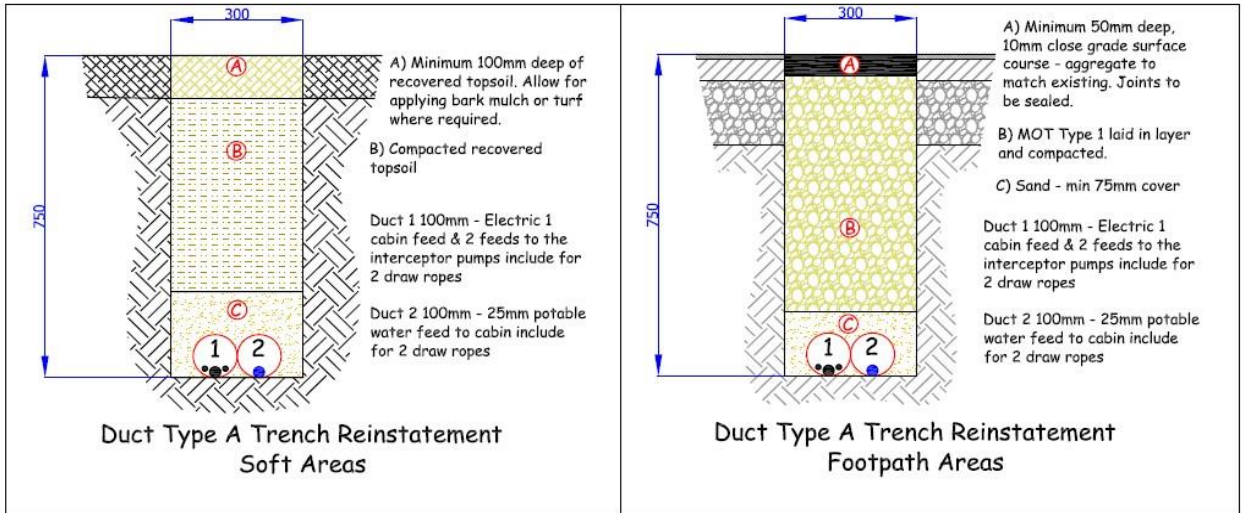

Service Ducting

The service ducting manholes should be no more than 50m apart.

Trench Type B From Store to Duct Chamber

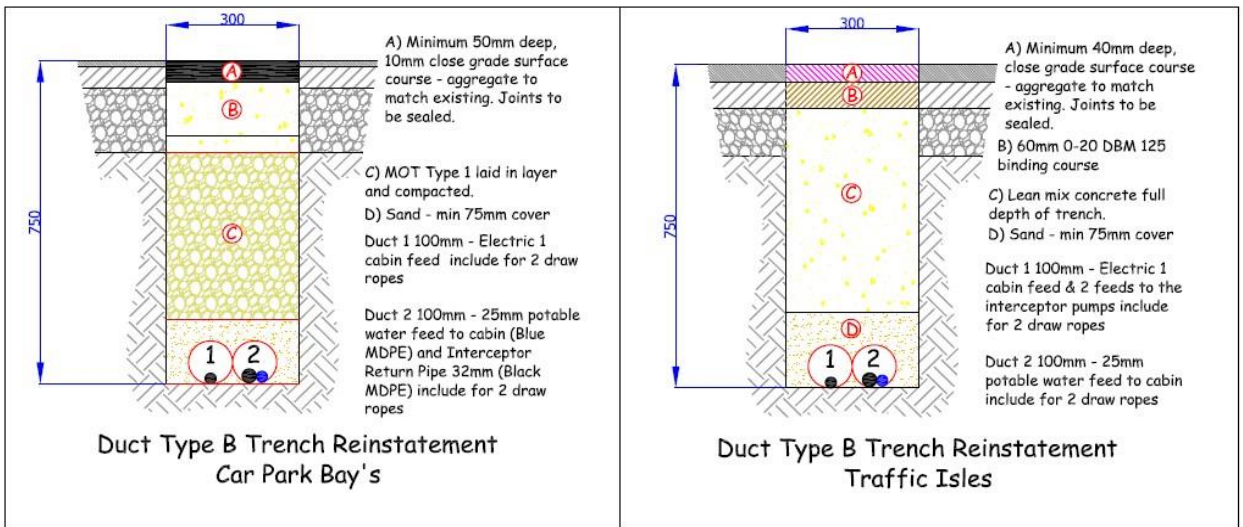
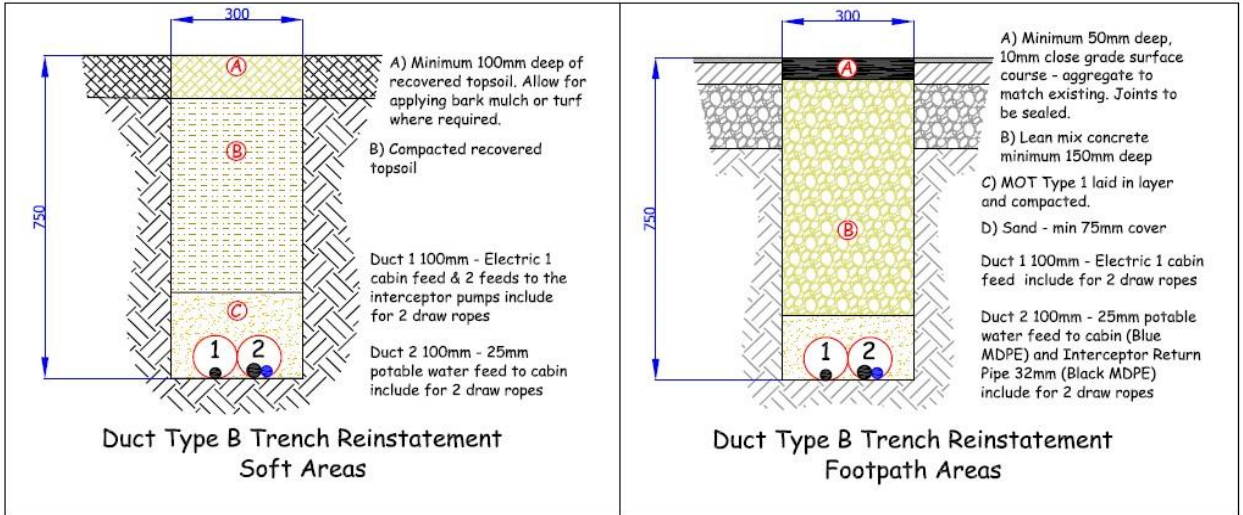

Service Ducting

The service ducting manholes should be no more than 50m apart.

Trench Type C From Cabin to Interceptor

Gully typical details

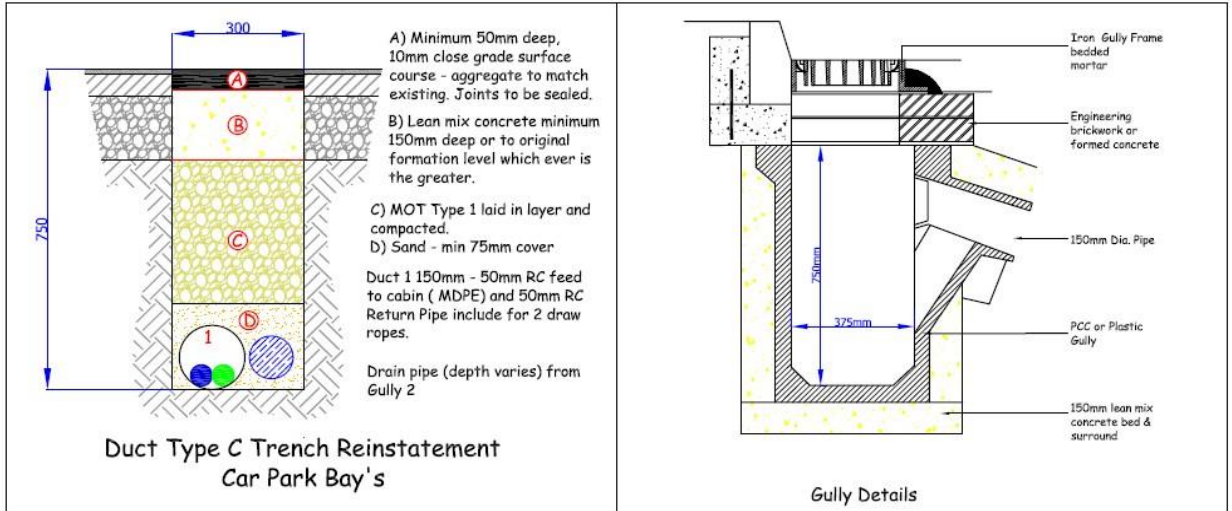

Typical Details of ACO installations

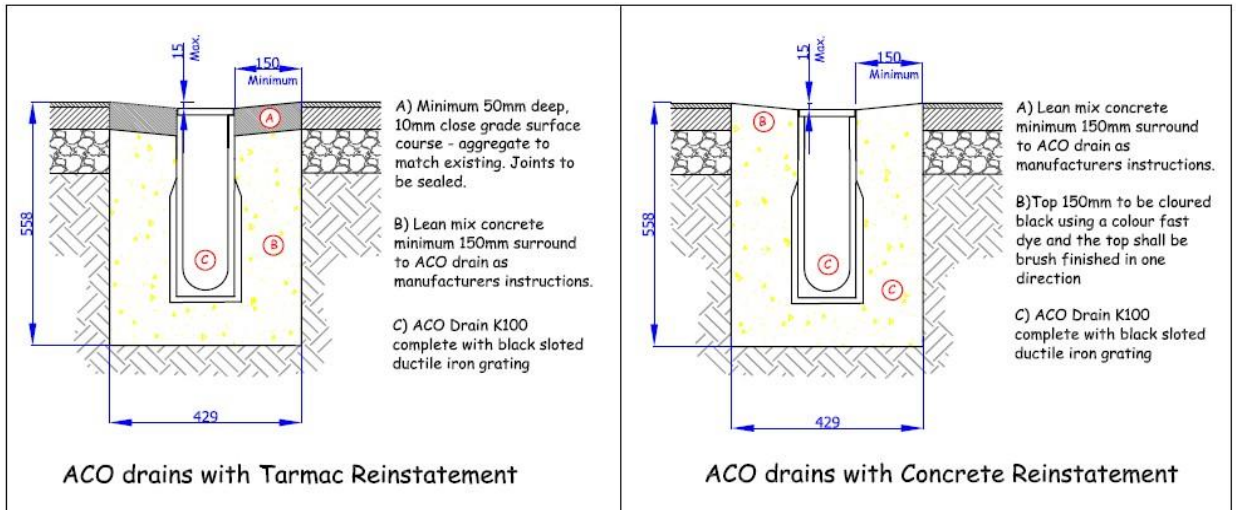

Service Ducting

The service ducting manholes should be no more than 50m apart.

Appendix 5 – Fire Risk Assessment

Fire Risk Assessment – Hand Car Wash

The car wash will be situated in an open-air environment and consist of a concrete wash pad, cabin and canopy. The car wash cabin will be made of steel and house no combustible equipment. The cabin will only be used to store car wash equipment and take payments from customers. Due to the small size of the cabin the entrance door will also function as an exit in the event of fire (please see page 5 for cabin plan). The two windows in the cabin are also openable to allow exit in the event of fire. Considering the location of the car wash and the proposed ancillary nature of the business the emergency assembly point will match that of the homebase store.

Car washes currently operated by Waves/Gilmore have been fire risk assessed and have been considered to have a low risk of fire. This installation will also be subject to the same mitigations to reduce the risk of fire (please see below a copy of Wave/Gilmore FRA)

[Fire Risk Assessment current Waves / Gilmore](#)



Hand Car Wash Fire Risk Assessment

Property address and use:	Waves / Tesco Hand Car Washes located in retail car parks		
Name of Responsible Person/Duty holder/Owner:	Franchisee		
Name of assessor:	David Newman MA, MIFireE, IOSH DPN Services Ltd		
Assessors signature:		Date of assessment:	

STEP 1: IDENTIFY HAZARDS – Sources of Ignition

Sources of ignition - sources of ignition include heaters, lighting, naked flames, electrical equipment, smokers' materials (cigarettes, matches etc.), and anything else that can get very hot or cause sparks.

Hazard	Steps taken to remove the hazard	Steps taken to reduce hazard
Smoking on premises	Smoking is prohibited on the premises at any time	
Electrical appliances	There is a strict regime ensuring that all electrical appliances are subjected to periodic PAT testing	Staff must be made aware that if they are using portable heaters that they should be positioned well away from combustible materials
Cooking	This consists of toaster, kettle, and microwave oven only	Fire extinguisher located in the Site Office/Cabin
Electrical – wiring and appliances	The electrical installation has been subjected to a periodic 5 year inspection by a competent engineer.	Electrical appliances are subjected to portable appliance testing [PAT] periodically
Client's vehicles	Client's vehicles are allocated specific parking bays away from the site cabins or any other structure	<ul style="list-style-type: none"> Fire extinguisher located in the Site Office/Cabin Staff have been trained as to actions to take in the event of a vehicle fire

Page 1 of 4

Fire Risk Assessment – Hand Car Wash

 Hand Car Wash Fire Risk Assessment		
STEP 1: IDENTIFY HAZARDS – Fuel Sources		
Fuel Sources - sources of fuel include wood, paper, plastic, rubber or foam, loose packaging materials, waste rubbish and furniture.		
Hazard	Steps taken to remove the hazard	Steps taken to reduce hazard
Furniture and furnishings	All furniture complies with the current Fire Safety Regulations	Smoke detection is positioned to give early warning to the occupants in the event of a fire
Storage of combustibles	Unnecessary combustible materials should be removed to reduce the likelihood/impact of a fire	Smoke detection is positioned to give early warning to the occupants in the event of a fire
Motor vehicles	Vehicles should only be parked in allocated parking bays	<ul style="list-style-type: none"> • Fire extinguisher located in the Site Office/Cabin • Staff have been trained as to actions to take in the event of a vehicle fire
Car washing products	Flammable materials to be located in the flame proof cabinet and subjected to COSHH data guidance in relation to use and storage	<ul style="list-style-type: none"> • Only small quantities of flammable material to be removed from cabinet at any one time • Fire extinguisher located in the Site Office/Cabin • Staff have been trained as to actions to take in the event of a vehicle fire
ACTION REQUIRED:	Nil	

Fire Risk Assessment – Hand Car Wash



Hand Car Wash Fire Risk Assessment

STEP 2: IDENTIFY PEOPLE AT RISK		
People at risk (including employees, visitors, contractors and neighbours.)		
People at risk	Why are they at risk	Measures in place to reduce/remove risk
Employees/visitors	It has been established that this is a relatively low risk environment for employees.	<ol style="list-style-type: none"> 1. Employees have received training in relation to fire awareness and what actions to take in the event of a fire 2. Adequate signage is present to assist with escape from the premises in the event of a fire 3. Smoke detection is located in the office 4. Adequate firefighting equipment has been installed and subjected to periodic visual checks
ACTION REQUIRED:	Ensure that all staff have received the relevant training in relation to fire	

Fire Risk Assessment – Hand Car Wash



Hand Car Wash Fire Risk Assessment

STEP 3: EVALUATE THE RISKS OF FIRE AND ASSESS EXISTING FIRE SAFETY MEASURES			
Accidental (e.g. smoking materials, candles or toasters)			
Hazard	Severity of hazard (Slight, Moderate, High)	Risk of fire (Unlikely, Likely, Very Likely)	Overall risk rating (High, Medium, Low)
Smoking	Nil	Nil	Nil
Cooking	Slight	Unlikely	L
Electrical appliances	Slight	Unlikely	L
Motor Vehicles	Moderate	Unlikely	L
ACTION REQUIRED:		No	No

STEP 4: RECORD SIGNIFICANT FINDINGS, ASSESS AND PLAN			
Significant finding	Priority: Low, Medium or High	Details of remedial action (if any)	Completion Date & sign
Annual Assessment/Review			
Assessment review date: 06/03/2025		Completed by: David Newman DPN Services Ltd	Signature:

Page 4 of 4

The operator will be made fully aware of this FRA and we will have a copy on site at all times.

Appendix 6 – Spill Kit Instructions

Emergency Spill Kit Instructions

An Emergency Spill Kit is supplied with each new Waves Car Wash and is used if an accidental spillage of chemicals or detergents occur

Instructions:

ALWAYS WEAR GOGGLES, GLOVES and OVERALLS when handling any chemicals

(Detergents and chemicals may only be mixed in the bunded wash area)

Any spillage in the bunded area must immediately be washed and brushed into the Aco drains with copious amounts of fresh water.

If an accidental spillage occurs outside the bunded area then immediately adopt the following procedure:

1. Immediately sprinkle the enclosed granules onto the spill liquid
2. Allow the granules to absorb the spill liquid
3. Sweep up the contaminated granules and place into the sack provided in this kit
4. Wash the contaminated area with a mop and bucket. The waste from this bucket must be placed into the FOUL drain and the mop and bucket well rinsed into the foul drain
5. The bag of contaminated granules must be labeled with contents and be removed to the local council tip and given in to the tip supervisor, informing him of the contents. The COSHH sheets in the back of the Waves Business Manual will prescribe disposal methods
6. Review your RISK ASSESMENT NOTICE and procedures to avoid future spills
7. Replace used granules as soon as possible (can be obtained from Head Office Tel: 020 8877 3884)

CONTENTS: Absorbent granules, latex gloves, goggles, disposal bags