

EXISTING RECEPTION WINDOW  
SCALE 1:10

DETAILS 1, 2, 3  
SCALE 1:2



Tel: 020 8017 1632  
info@londonsash.com  
The London Sash Window Company  
41 High Street, London SE20 7HJ

DO NOT SCALE THIS DRAWING. USE FIGURE DIMENSIONS

NOTES:

- A) Timber: Scandinavian redwood (softwood).
- B) 4mm clear float glass fitted with heritage putty.
- C) Bottom rail – 75mm.
- D) Meeting rail – 38mm.
- E) Top rail – 53mm.
- F) Inside Head – 55mm.
- G) Hardwood sill – 68 x 200mm.
- H) Staff bead – 15mm x 20mm.
- I) Parting bead – 7mm x 25mm.

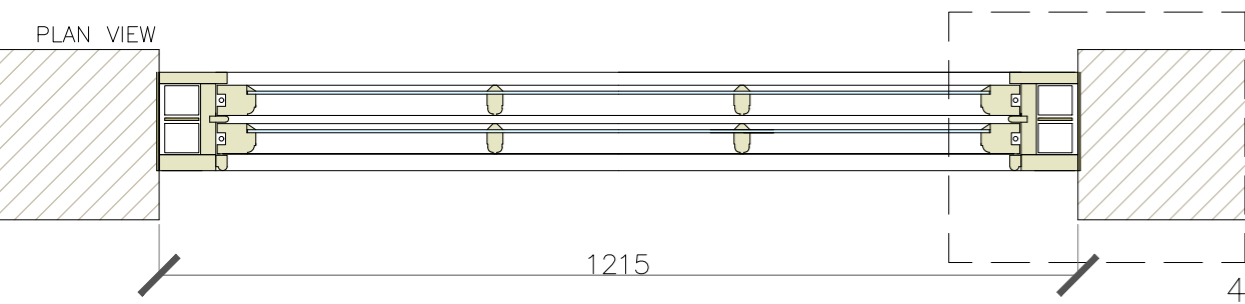
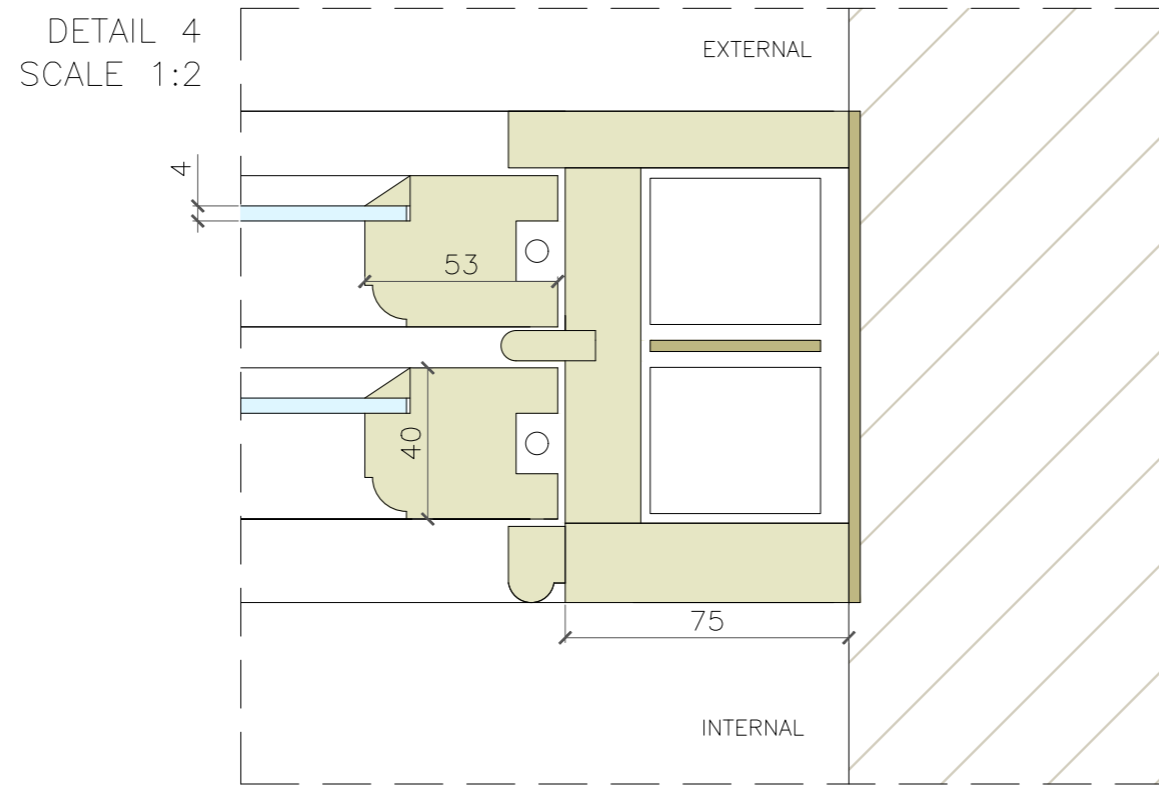
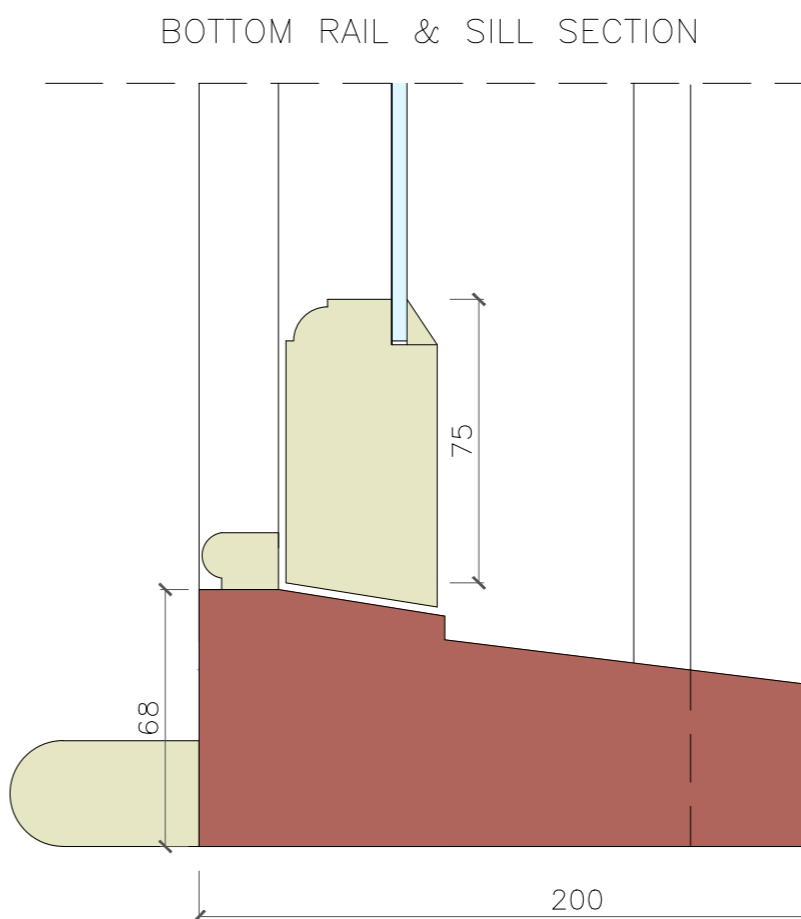
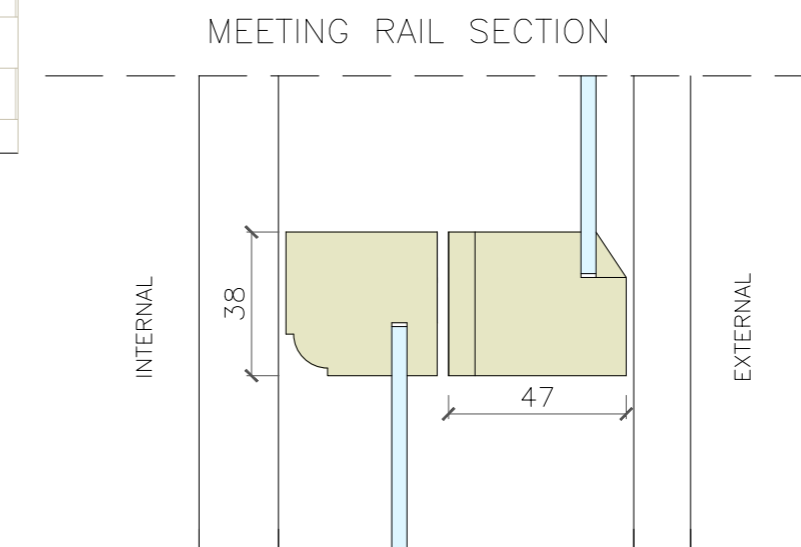
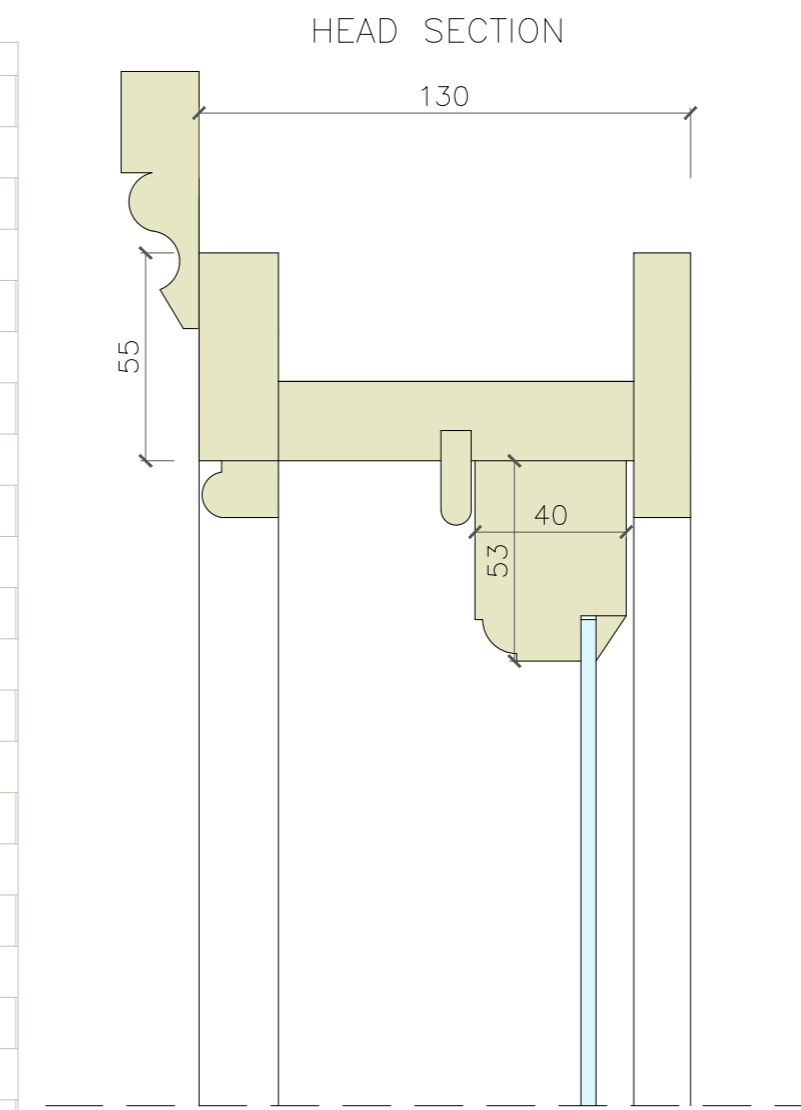
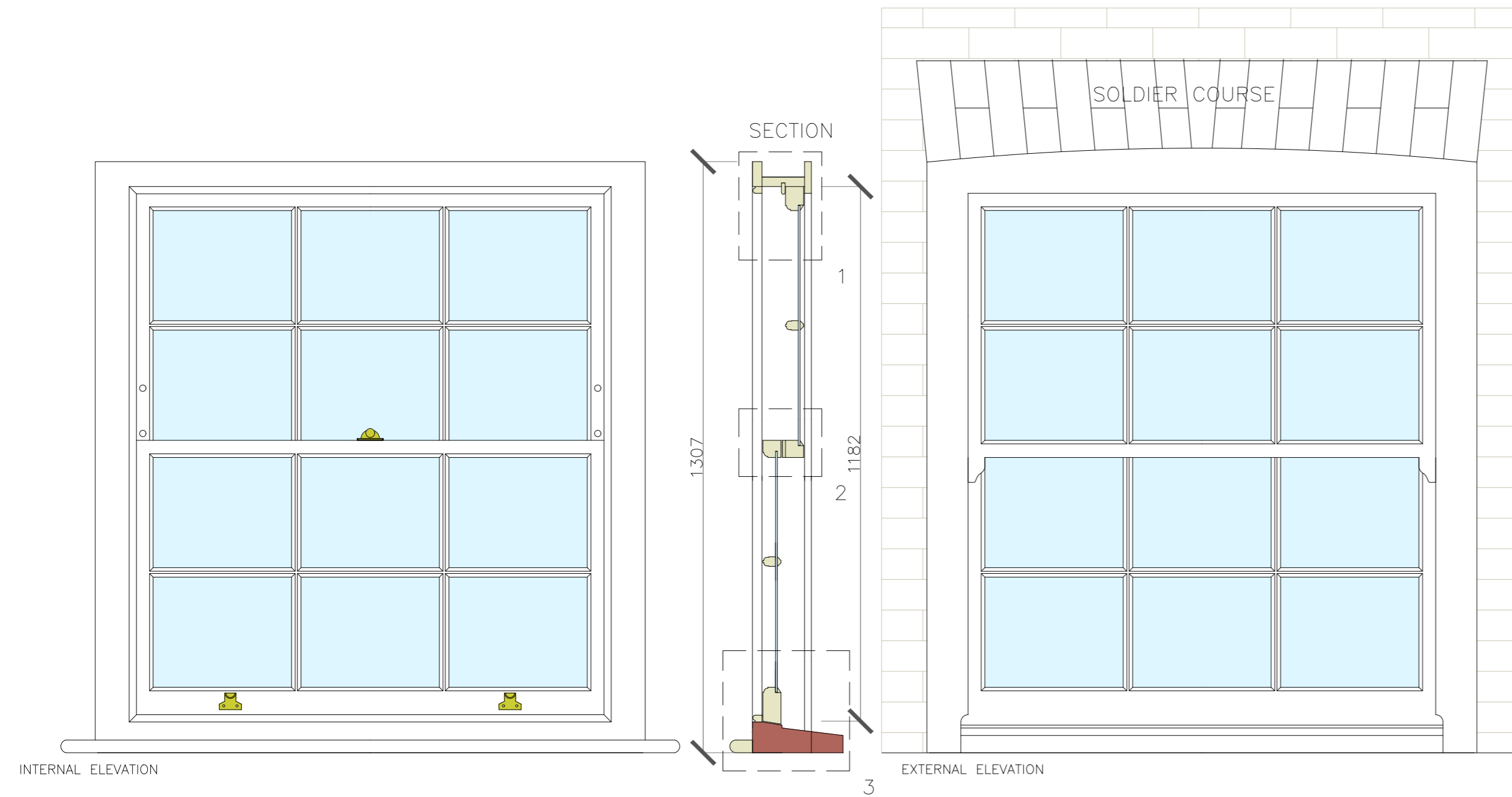

ITEM DETAILS  
SCALE 1:2

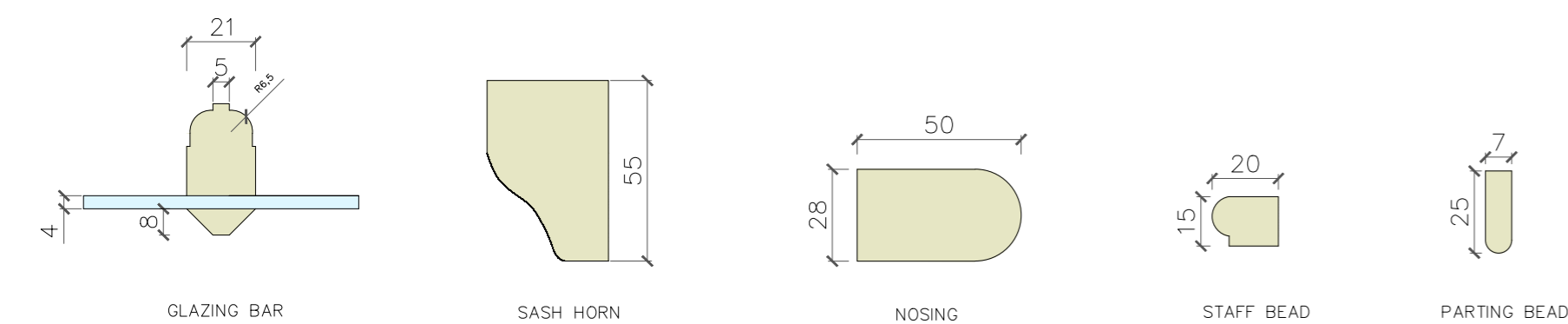

CLIENT: Francesca Panzarasa

LOCATION: TW9 1EB

SCALE: Drawing scale @A2

DRAWN BY: TB

DATE **29 August 2024**

DRAWING TITLE: Existing Reception Window

DRAWING NUMBER: Exis\_Rec\_Win

PURPOSE OF ISSUE: For Planning

QUANTITY: 1

REVISION: **B**

PROPOSED RECEPTION WINDOW  
SCALE 1:10

DETAILS 1, 2, 3  
SCALE 1:2



Tel: 020 8017 1632  
info@londonsash.com  
The London Sash Window Company  
41 High Street, London SE20 7HJ

DO NOT SCALE THIS DRAWING. USE FIGURE DIMENSIONS

- NOTES:
- A) Timber: Accoya.
  - B) 4mm Low-e glass to internal pane.  
10mm warm edge spacer bar. argon filled.  
4mm clear float glass to external pane.
  - C) Paint Colour: RAL 9016. Eggshell finish (inside & out)
  - D) Internal "OVOLO" mould.
  - E) Bottom rail – 75mm.
  - F) Meeting rail – 38mm.
  - G) Top rail – 53mm.
  - H) Inside Head – 55mm.
  - I) Hardwood sill – 68 x 200mm.
  - J) Staff bead – 15mm x 20mm.
  - K) Parting bead – 7mm x 25mm.
  - L) Draught exclusion weather seal.
  - M) 3" Ogee Architrave .
  - N) Bull nosing – 28mm x 50mm.
  - O) Brighton fastener
  - P) Sash lifts
  - Q) Rola lock – Key operated
  - R) Trickle vent fitted to frames as per building regulation.

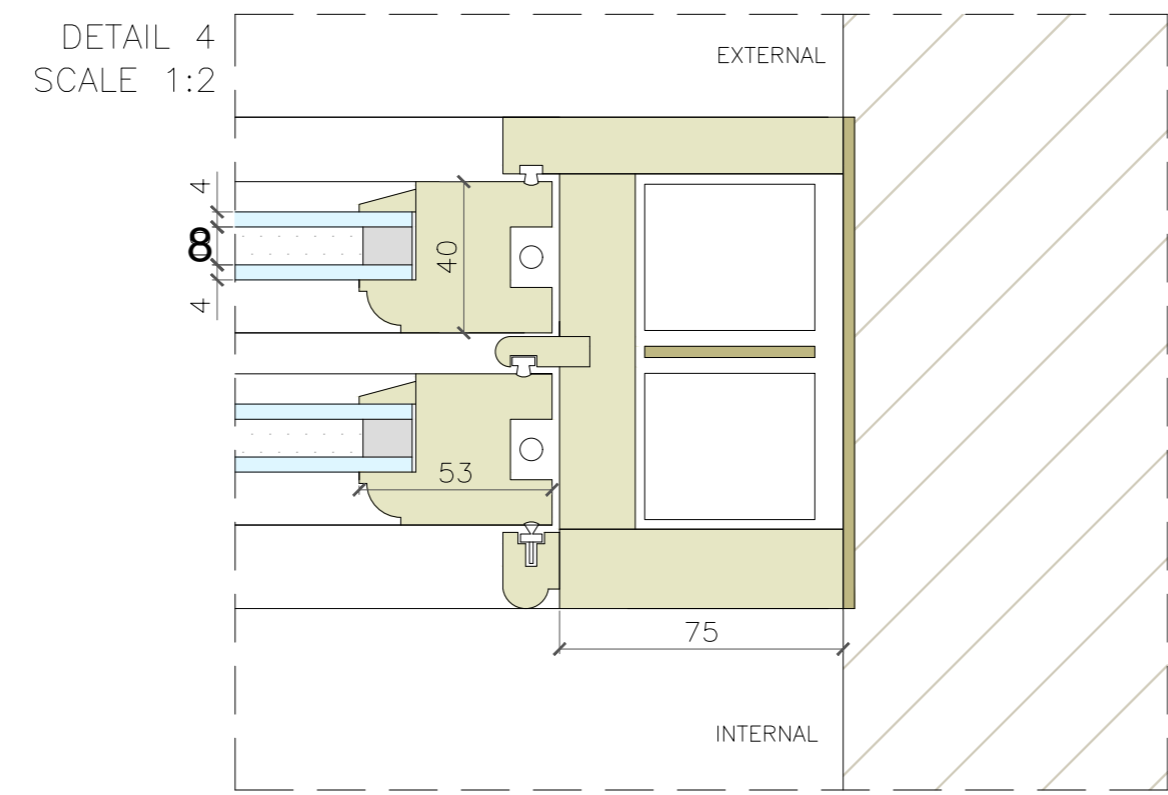
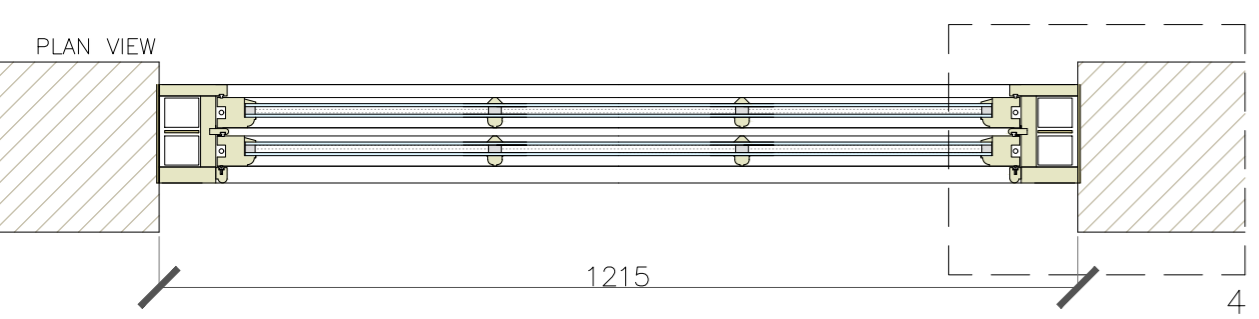
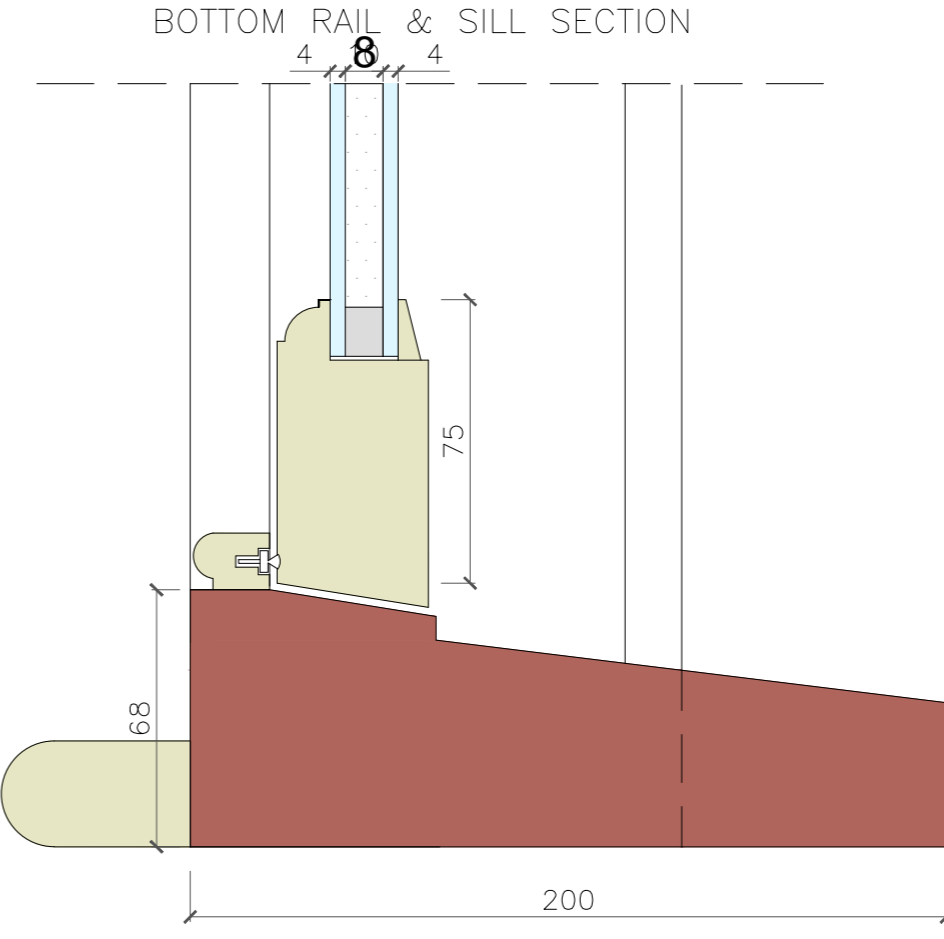
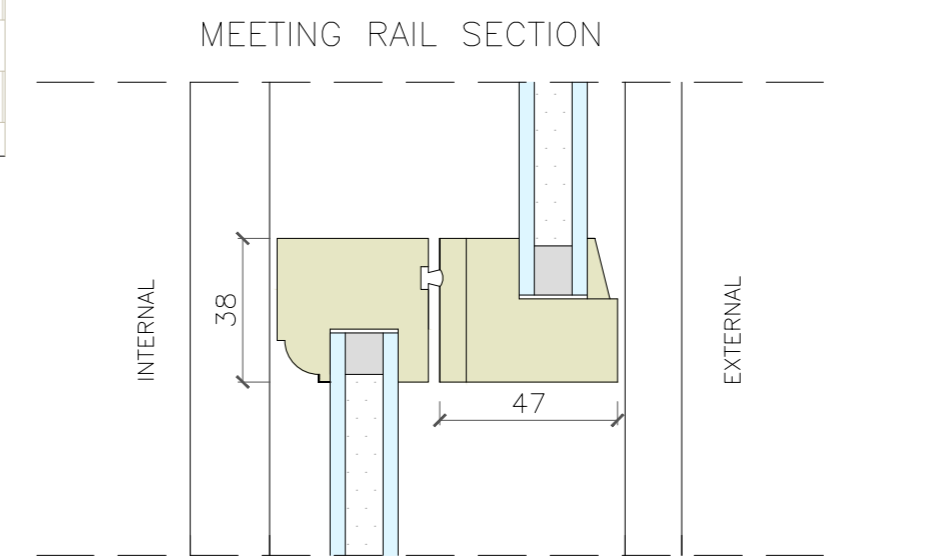
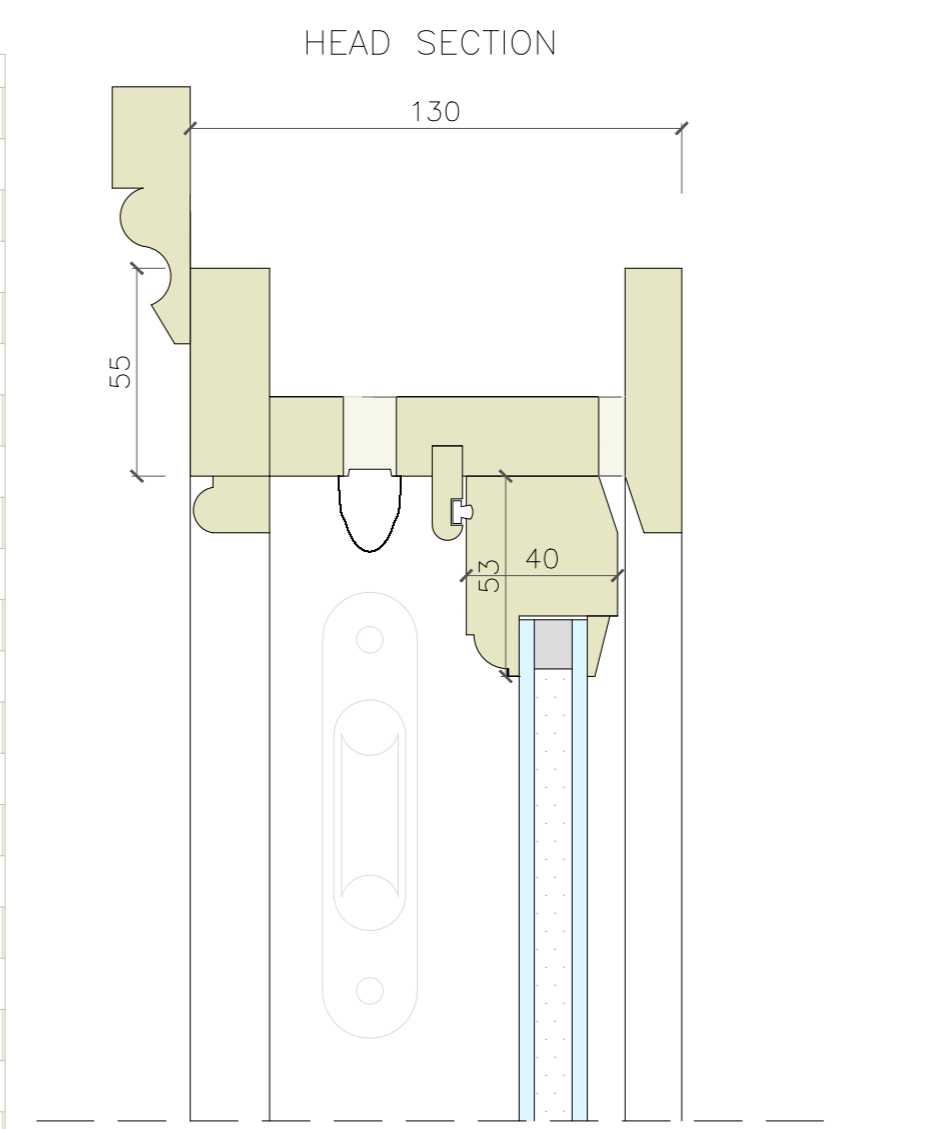
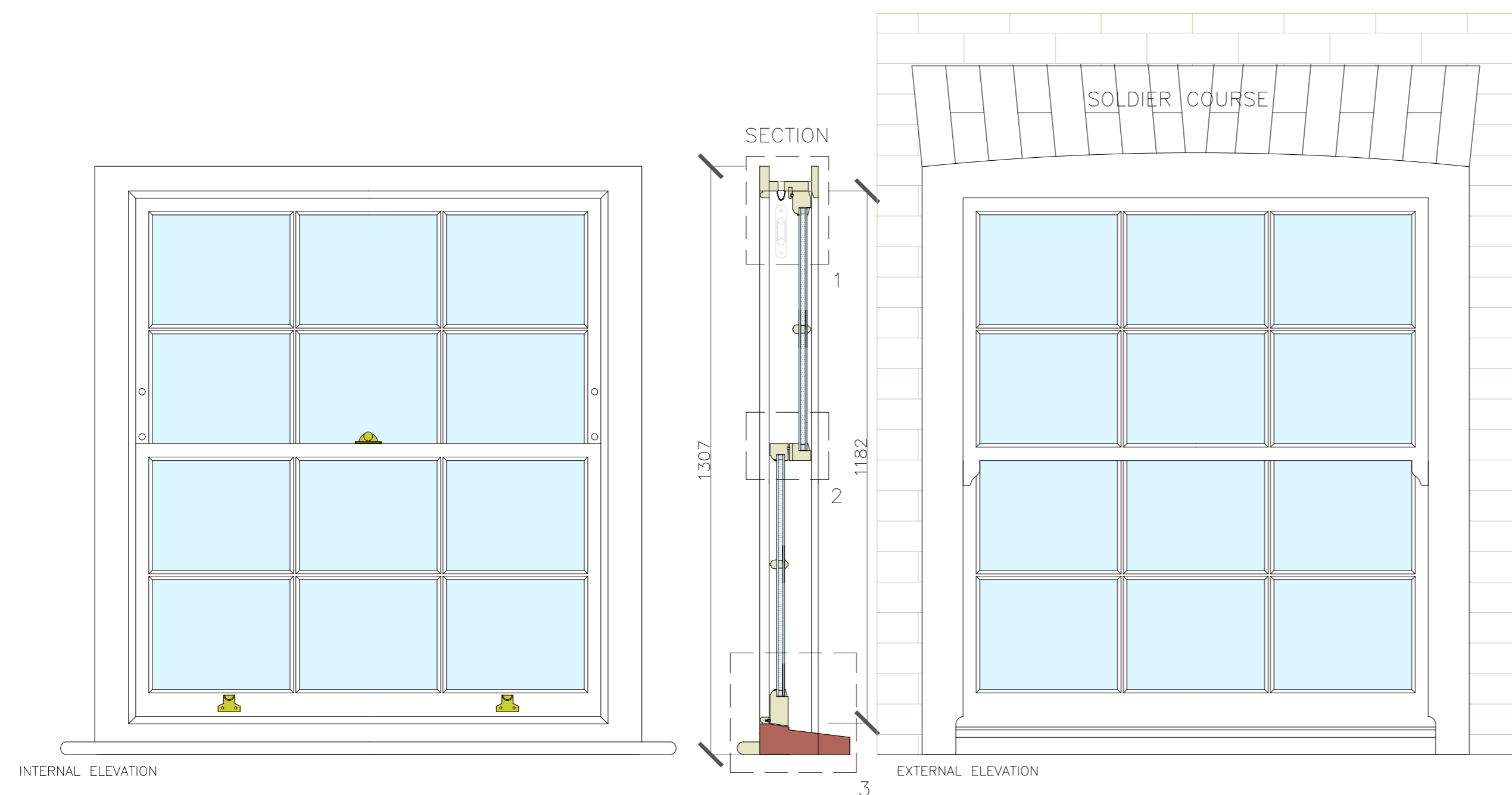

ITEM DETAILS  
SCALE 1:2

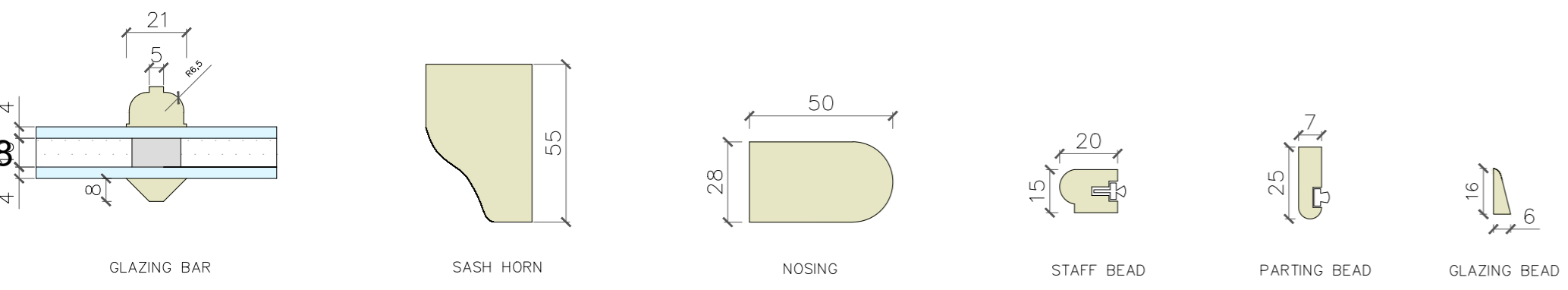

CLIENT:	Francesca Panzarasa
LOCATION:	TW9 1EB
SCALE:	Drawing scale @A2
DRAWN BY:	TB
DATE	<b>29 August 2024</b>
DRAWING TITLE:	Proposed Reception Window
DRAWING NUMBER:	Prop_Rec_Win
PURPOSE OF ISSUE:	For Planning
QUANTITY:	1
REVISION:	<b>B</b>