

Second Floor Door Location Plan
scale 1:200 @ A3

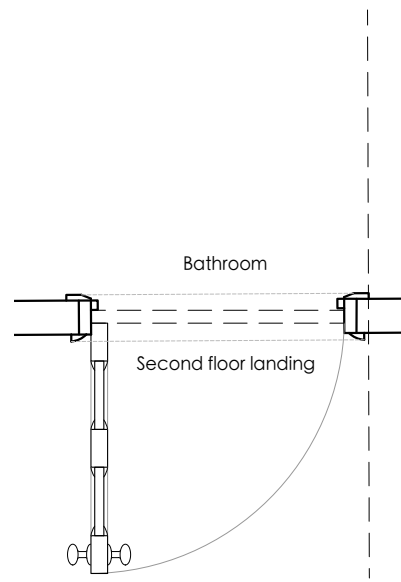

Existing plan
scale 1:20 @ A3

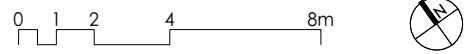
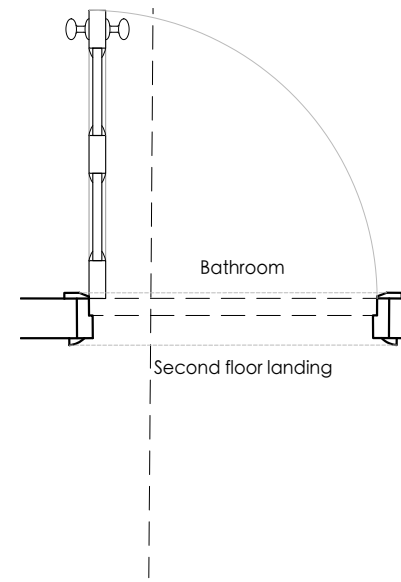

Proposed plan
scale 1:20 @ A3

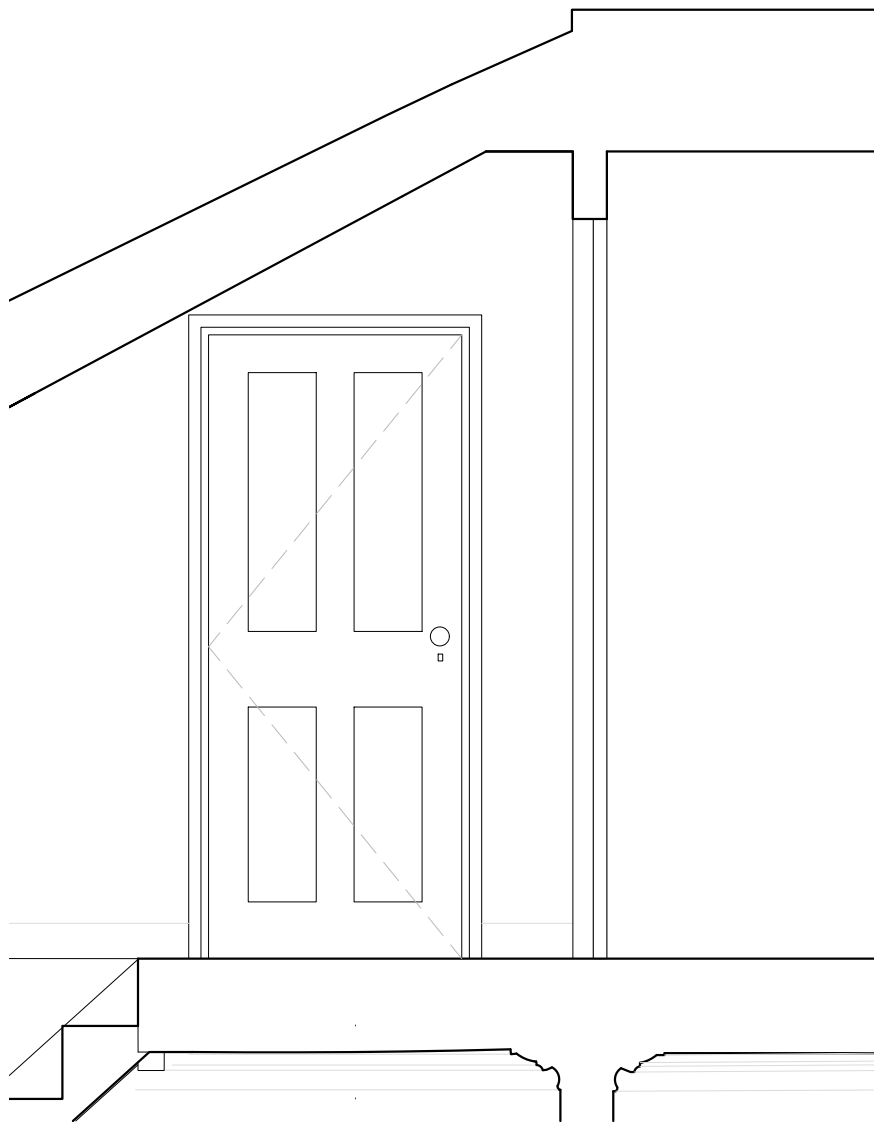

Existing internal elevation
scale 1:20 @ A3

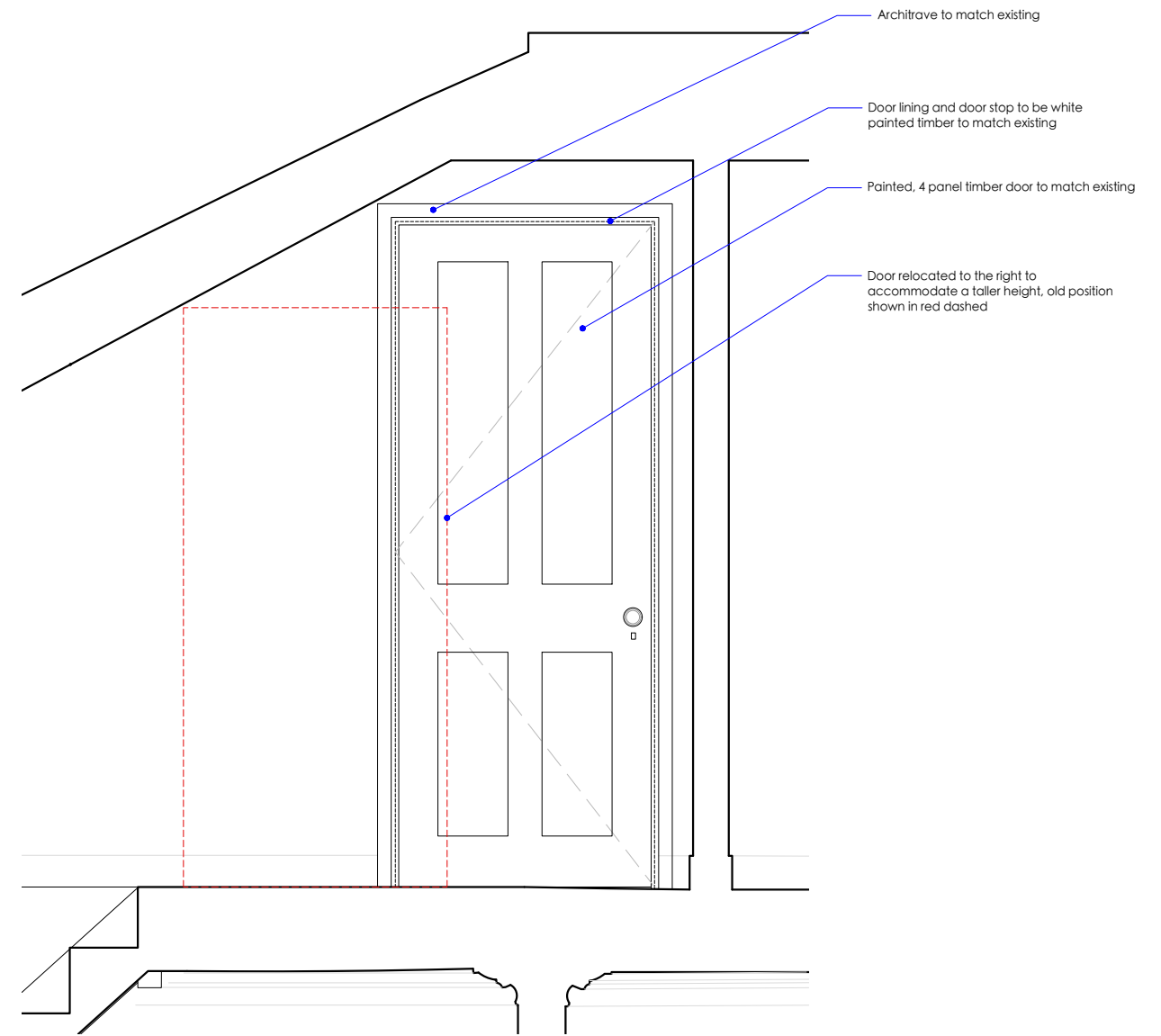

Proposed internal elevation
scale 1:20 @ A3

