

# Acoustic assessment of a proposed music school

Richmond Brewery Stores, Petersham Road, Richmond TW10 6UW



Client: School of Rock

Report Reference: 240807-R001A

Date: 6<sup>th</sup> September 2024

| <b>Revision:</b> | <b>Date:</b> | <b>Author:</b>              | <b>Checked:</b>        |
|------------------|--------------|-----------------------------|------------------------|
| A                | 06/09/2024   | Sam Message BSc (Hons) MIOA | Rob Cant MIOA MIEEnvSc |

This report has been prepared by ACA Acoustics Limited (ACA) with all reasonable skill, care, and diligence in accordance with generally accepted acoustic consultancy principles and taking account of the services and terms agreed between ACA and our client. Any information provided by third parties and referred to herein may not have been checked or verified by ACA unless expressly stated otherwise. Certain statements made in the report may constitute estimates or projections and even though these are based on reasonable assumptions and good industry practice, such forward-looking statements by their nature involve risks and uncertainties which could cause actual results to differ materially from the results predicted. ACA does not guarantee or warrant any estimate or projection contained in this report.

Note that consideration of non-acoustic aspects including, but not limited to structural calculations, compliance with Building Regulations and other statutory requirements, or any assessment of fire regulations are outside the scope of ACA Acoustics Limited and should be considered by others accordingly.

This report is confidential to the client and ACA accepts no responsibility whatsoever to third parties unless formally agreed by ACA. Any such party relies upon the report at their own risk. © 2024 ACA Acoustics Limited.

## CONTENTS

|  |    |
|--|----|
| 0. SUMMARY .....   | 2  |
| 1. INTRODUCTION .....  | 3  |
| 2. ACOUSTIC CRITERIA .....   | 3  |
| 2.1. Local Authority – Entertainment Noise.....                          | 3  |
| 2.2. Local Authority – Mechanical Plant Noise .....                      | 4  |
| 3. REVIEW OF SITE LOCATION & DEVELOPMENT PROPOSALS .....                 | 5  |
| 4. SOUND LEVEL SURVEY .....  | 7  |
| 4.1. Internal Sound Level Survey.....                                    | 7  |
| 4.2. External Sound Level Survey .....                                   | 8  |
| 5. ASSESSMENT OF OPERATIONAL NOISE TO ADJOINING PROPERTIES .....         | 10 |
| 5.1. Source Sound Levels .....   | 10 |
| 5.2. Acoustic Assessment of Internal Operational Noise Transmission..... | 10 |
| 5.3. External Noise Egress.....  | 11 |
| 6. MITIGATION REQUIREMENTS .....   | 12 |
| 6.1. Acoustic Ceilings.....  | 12 |
| 6.2. 1 <sup>st</sup> Floor Separating Wall.....                          | 12 |
| 6.3. Calculated Resultant Sound Levels with Mitigation Scheme.....       | 12 |
| 7. MECHANICAL PLANT .....  | 13 |
| 8. CONCLUSION.....   | 13 |
| Appendix A.....  | A  |
| Appendix B .....   | B  |

## 0. SUMMARY

- 0.1. ACA Acoustics Limited has been commissioned to carry out an acoustic assessment of a proposed new music school facility at Richmond Brewery Stores, Petersham Road, Richmond.
- 0.2. Referring to Local Authority guidelines, ACA Acoustics recommend that operational noise emissions to the above residential spaces should be  $\leq$ NR25 and  $\leq$ LCEq 48dB and  $\leq$ NR25 to the above office spaces.
- 0.3. Sound insulation tests have been carried out on the existing structure between the ground and 1<sup>st</sup> floor areas and the adjoining commercial/residential premises on 22<sup>nd</sup> August 2024. Using the results of the testing an assessment of operational noise transmission has been carried out.
- 0.4. A detailed scheme of acoustic mitigation works has been developed and presented in this report which demonstrate that the relevant internal noise levels can be achieved.
- 0.5. Subject to the mitigation works detailed in this report being implemented correctly, resultant sound levels inside the above offices will be  $\leq$ NR19 and  $\leq$ LCEq 45dB /  $\leq$ NR20 in the above residential premises and will therefore comply with the requirements stipulated by the Local Authority.
- 0.6. In terms of noise breakout, it is recommended that the LAeq, 5 min to not exceed the background LA90, 5min. In this case the LA90 has been calculated to be 48dB. It has been calculated that no additional measures are required to achieve the criteria for external noise breakout.
- 0.7. Plant details for the development are not yet known, however the plant shall be selected/located/mitigated to ensure the sound levels are  $\leq$ 43dBA at 1m outside the nearest residential window. This is 5dBA below the prevailing background sound levels.
- 0.8. Allowing for the proposed mitigation measures set out in this report, noise from the proposed music school will not be disturbing or detrimental to the amenity of closest residential receptors.

## 1. INTRODUCTION

The client is preparing an application seeking consent to develop a new music tuition facility within the Richmond Brewery Stores site on Petersham Road, Richmond.

ACA Acoustics Limited has been commissioned to carry out a survey and assessment of noise transmission from the proposed music school to adjoining residential premises and, where necessary, to make recommendations for a suitable sound mitigation scheme.

This report presents results of the background sound level survey, sound insulation testing and assessment.

## 2. ACOUSTIC CRITERIA

### 2.1. Local Authority – Entertainment Noise

The London Boroughs of Hillingdon, Hounslow & Richmond provide a supplementary planning document titled ‘Development Control for Noise Generating and Noise Sensitive Development.’ Table 4 within Section 7 of this document provides guidance pertinent to places of entertainment. Whilst not strictly applicable to this site, it is assessed that due to the live music elements, it provides the most suitable criteria for operational noise from this development to be assessed against.

**Table 4: Entertainment Noise - Noise Standards**

| Location | Time        | Criteria  |
|----------|-------------|---|
| External | 9am to 11pm | $L_{Aeq,5min}$ EN minus $L_{Aeq,5min}$ OR $L_{A90,5min}$ WEN = 0 to +5 dBA.   |
|          |             | $L_{Ceq,5min}$ EN minus $L_{Ceq,5min}$ OR $L_{C90,5min}$ WEN = 0 to +5 dBC.   |
|          | 11pm to 9am | $L_{Aeq,5min}$ EN minus $L_{Aeq,5min}$ OR $L_{A90,5min}$ WEN = -5 to +3 dBA.  |
|          |             | $L_{Ceq,5min}$ EN minus $L_{Ceq,5min}$ OR $L_{C90,5min}$ WEN = -10 to +3 dBC. |
| Internal | 9am to 11pm | EN = Noise Rating NR25-35 $L_{eq,5mins}$                                      |
|          |             | $L_{Ceq,5min}$ EN minus $L_{Ceq,5min}$ OR $L_{C90,5min}$ WEN = -10 to +5 dBC. |
|          | 11pm to 9am | EN = Noise Rating NR15-25 $L_{eq,5mins}$                                      |
|          |             | $L_{Ceq,5min}$ EN minus $L_{Ceq,5min}$ OR $L_{C90,5min}$ WEN = -10 to 0 dBC.  |

Figure 1: Criteria table taken from Richmond SPD

The music school will only be open during daytime hours, therefore in terms of internal criteria operational noise emissions from the proposed music school will be controlled to not exceed a level of NR25 ( $L_{eq,5min}$ ) and for the  $L_{Ceq,5min}$  to be at least 5dB below the background  $L_{C90,5min}$  within the upper floor residential apartments. Sound levels to inside the adjoining 1<sup>st</sup> floor offices have been designed to not exceed a level of NR25 ( $L_{eq,5min}$ ).

## 2.2. Local Authority – Mechanical Plant Noise

London Borough of Richmond upon Thames Council’s policies relating to noise are contained within the Council’s Supplementary Planning Document *Noise Generated and Noise Sensitive Development*, written in conjunction with the Boroughs of Hillingdon and Hounslow.

Section 6 relates to noise noise-generated industrial and commercial development and confirms that *“all industrial and commercial development with the potential to generate noise will be assessed and, where relevant, controlled by planning conditions in order to protect residential amenity ... the most relevant standard for assessing new industrial and commercial development is BS 4142:2014”*.

The scope of BS 4142:2014+A1:2019 advises that *“this British Standard describes methods for rating and assessing sound of an industrial and/or commercial nature ... to assess the likely effects of sound on people who might be inside or outside a dwelling or premises used for residential purposes upon which sound is incident”*. BS 4142:2014+A1:2019 is commonly used to assess the potential for loss of amenity due to noise from mechanical services equipment and is considered appropriate for this application.

The assessment method of BS 4142:2014+A1:2019 corrects the specific sound level from the source under investigation to account for characteristics that could make the sound more obtrusive to obtain a rating level. This rating level is compared against the prevailing background noise outside the noise-sensitive property. Section 11 of BS 4142:2014+A1:2019 provides a commentary of the assessment result and advises that:

- a) The greater the difference between the rating level and the background sound level, the greater the magnitude of the impact;
- b) A difference of around +10dB or more is likely to be an indication of a significant adverse impact, depending on the context;
- c) A difference of around +5dB is likely to be an indication of an adverse impact, depending on the context;
- d) The lower the rating level is to the measured background sound level, the less likely it is that the specific sound source will have an adverse impact or a significant adverse impact. Where the rating level does not exceed the background sound level, this is an indication of the specific sound source having a low impact, depending on the context.

Typically, ACA Acoustics recommends designing the rating level of sound emissions from new mechanical plant to not exceed the background sound level at the nearest residential dwellings, thus achieving a ‘low impact’ as defined in BS 4142:2014+A1:2019. Albeit the context of the development must be considered on a project-by-project basis which can alter the initial assessment result. However, in this instance Richmond upon Thames Council have their own judgement of the BS 4142:2014 assessment outcome, as set out in Table 2 of the SPD and shown in Table 1 below.

| Noise Impact from Relevant Proposed Industrial or Commercial Premises or Plant | Development Outcome   |
|--|---|
| Rating level (LAr, Tr) is at least 5dBA below the Background Level LA90        | Normally acceptable   |
| Rating Level (LAr, Tr) is no more than 5dBA above the Background Level LA90    | Acceptable only if there are overriding economic or social reasons for development to proceed |
| Rating Level (LAr, Tr) is more than 5dBA above the Background Level LA90       | Normally unacceptable   |

Table 1: London Borough of Richmond upon Thames' external noise standards

Section 6.3 of the SPD advises that for some projects it may also be appropriate to predict internal sound levels within nearby dwellings, in addition to the assessment of noise to outside these properties.

### 3. REVIEW OF SITE LOCATION & DEVELOPMENT PROPOSALS

The proposals include developing the northern side of the ground floor and part of the first floor of the building into a new music school. The remainder of the ground and first floors will remain office use and there are residential flats on the second floor of the site.

It is understood the proposed opening times of the facility will be 10:00 – 22:30 weekdays and 10:00 – 18:00 on Saturdays.

Figures 2 & 3 below shows the site within the surrounding vicinity for context.

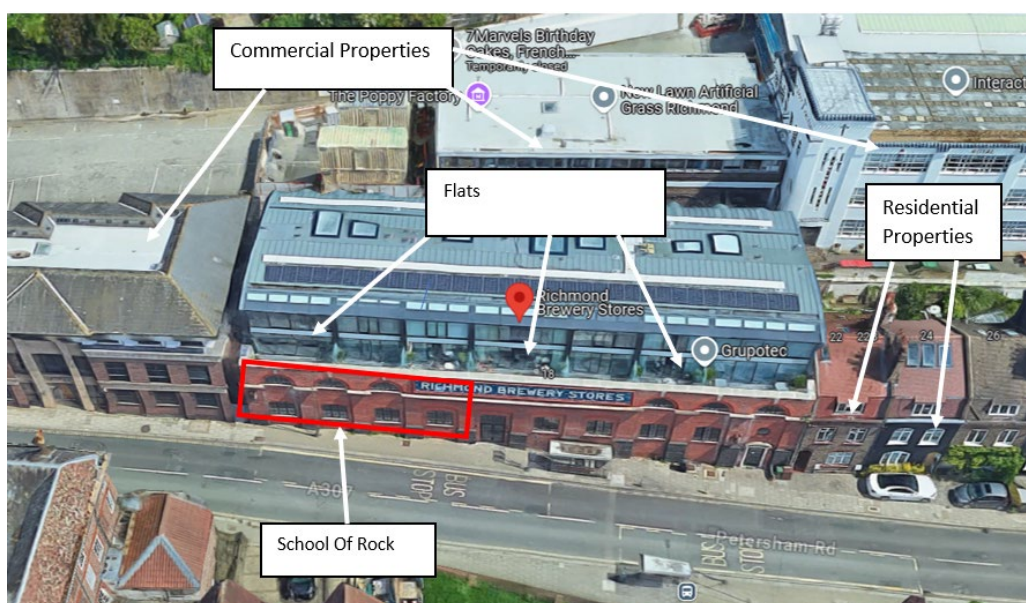

Figure 2: Front facade showing site location and closest receptors





## 4. SOUND LEVEL SURVEY

### 4.1. Internal Sound Level Survey

A survey of the sound insulation performance of the separating floor between the proposed development unit and the residential units above, along with sound insulation between ground and first floor levels has been carried out.

The survey was conducted by Sam Message of ACA Acoustics on 22<sup>nd</sup> August 2024. Tests were conducted in accordance with the methodology of BS EN ISO 16283-1:2014.

Results of the measured level difference, in terms of weighted single-figure value, is shown in the table below. Full results are included in Appendix A.

| Test Reference | Source Room                          | Receiving Room                            | Level Difference $D_{w}$ (dB) (C'tr)      |
|----------------|--------------------------------------|---|---|
| AF01           | Ground floor open area               | 1 <sup>st</sup> floor open area           | 52(-3) dB*                                |
| AF02           | Ground floor offices                 | 1 <sup>st</sup> floor offices             | 66(-9) dB                                 |
| AF03           | 1 <sup>st</sup> Floor open plan area | 2 <sup>nd</sup> floor residential hallway | 61(-9) dB                                 |
| AF04           | Ground floor open area               | 2 <sup>nd</sup> floor residential hallway | - Not audible and no measurement possible |

*Table 2: Sound insulation test results*

\* This test was compromised due to small gaps in the separating floor, however for robustness AF01 has been used as the basis for the assessment.

A test between the ground floor open area and 2<sup>nd</sup> floor residential hallway was attempted, however even with the loudspeaker turned up fully to around LAeq 105dB, no noise was audible/measurable to the second floor level. This provides positive indication that very high sound levels at ground floor level will not impact top floor residents.

During the sound insulation tests the internal background level was also measured within the 2<sup>nd</sup> floor hallways. A level of LA90 30dB / LC90 48dB was measured and will be used for the assessment. As the hallway is to the rear of the property and screened from the main road with sealed windows, this is considered a robust measurement.

During the sound insulation testing noise breakout through the external façade (with windows closed) was also conducted. At 1m from a window the following reduction values were measured.

| <b>63</b> | <b>125</b> | <b>250</b> | <b>500</b> | <b>1k</b> | <b>2k</b> | <b>4k</b> | <b>8k</b> | <b>Dw</b> |
|-----------|------------|------------|------------|-----------|-----------|-----------|-----------|-----------|
| 24        | 28         | 31         | 39         | 39        | 44        | 40        | 51        | 40        |

*Table 3: Sound reduction measured through external facade*

## 4.2. External Sound Level Survey

To assess sound levels from new mechanical equipment and sound breakout from the development, it is necessary to establish representative background sound levels in the vicinity during the proposed plant operating times.

The background sound level was measured via an unattended survey at the position indicated in Figure 3. This position was considered as being representative of the NSR1 receptor. The survey was set up by Sam Message of ACA Acoustics and conducted between the 22<sup>nd</sup> and 23<sup>rd</sup> August 2024.

During the survey, the soundscape in the vicinity was influenced predominantly by local and distant road traffic as well as car park activity including frequent delivery vans.

The following equipment was used during the survey. An on-site calibration check was conducted on the sound level meter prior to the survey and repeated after with no deviation noted.

| <b>Equipment</b>   | <b>Serial Number</b> |
|--|----------------------|
| NTi Audio Class 1 sound level meter type XL2-TA              | A2A-18128-E0         |
| Svantek calibrator type SV33B. Compliant to IEC 60942-1:2003 | 10436                |

*Table 4: Equipment used for the sound level survey*

Weather conditions at the time of setting up the survey consisted of 50% cloud, light winds, dry ground conditions and a temperature of around 25°C. Weather conditions have been reviewed at [www.worldweatheronline.com](http://www.worldweatheronline.com), using the closest available commercial weather station. Weather conditions remained predominantly calm and dry with wind speeds below recommended limits during the proposed equipment operation times. Meteorological conditions are considered acceptable and will not have adversely impacted the survey results.

Results of the survey are shown in graphical form in Figure 6 below.

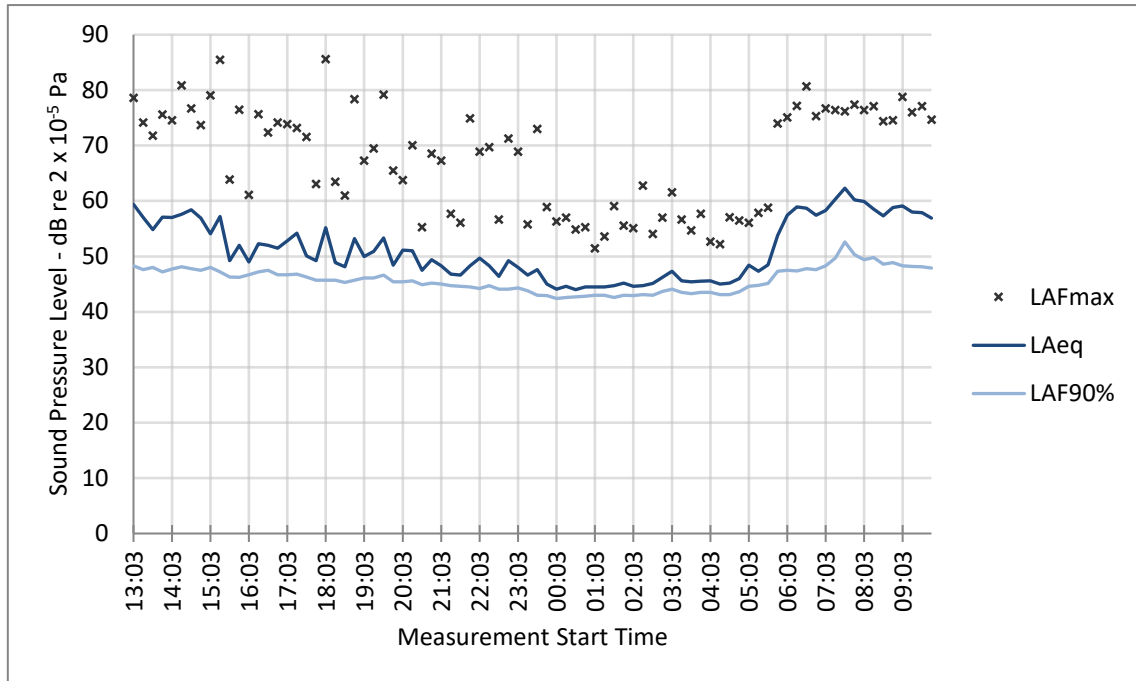

Figure 6: Sound level survey results – 22<sup>nd</sup> – 23<sup>rd</sup> August 2024

In accordance with the methodology set out in BS 4142:2014+A1:2019, the background sound level is not necessarily the lowest recorded value. Instead, the background sound level should be a level which is representative of the underlying soundscape at the receptor location.

A statistical analysis of the measured LA90 results during daytime hours is shown in Figure 7 below, following guidance set out in the Standard.

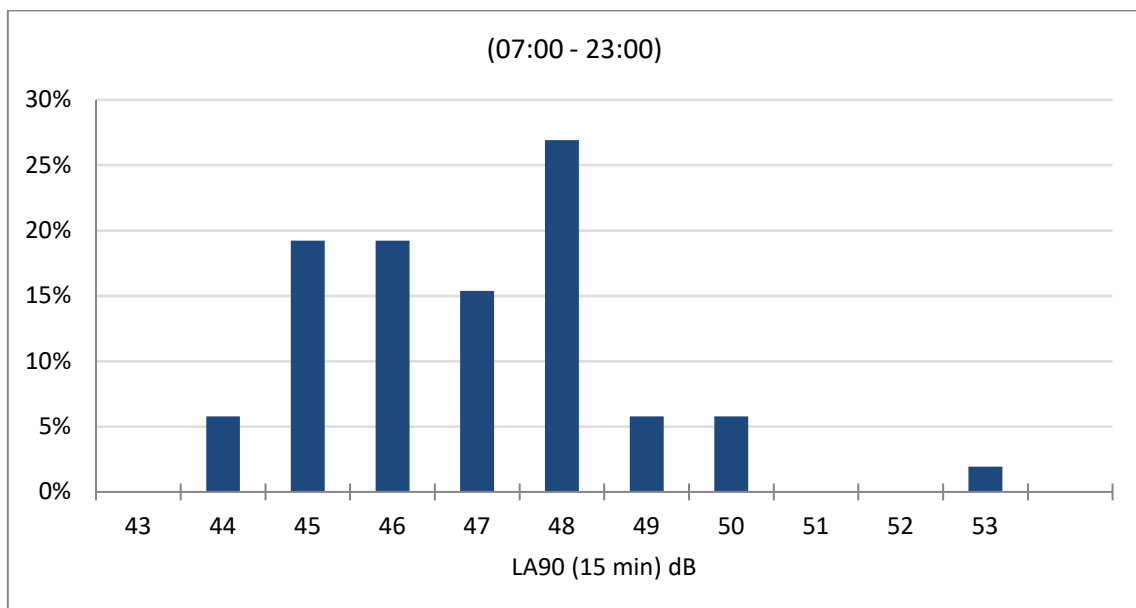

Figure 7: Statistical analysis of measured LA90 sound levels during the assessment period

Based on the statistical analysis of the survey results, the author considers a level of LA90 48dB /LC90 58dB is representative of the background sound level in the vicinity.

Summary results of the survey are provided in Table 4 below.

| Receptor | Period         | Background Sound Level During Operating Period |
|----------|----------------|--|
| NSR1     | 07:00 to 23:00 | LA90 48dB<br>LC90 58dB                         |

Table 5: Summary sound level survey results

## 5. ASSESSMENT OF OPERATIONAL NOISE TO ADJOINING PROPERTIES

### 5.1. Source Sound Levels

To calculate the potential impact of the proposed development it is necessary to establish typical sound levels within different rooms of the facility.

ACA Acoustics have previously recorded sound levels in existing similar facilities. Spectra used in the assessment equates to an overall sound level of LAeq 102dB for the rehearsal, drum rooms and multiuse rooms and a level of LAeq 91dB in the 1<sup>st</sup> floor smaller individual teaching classrooms. These are considered to be absolute 'worst-case' levels and unlikely to be exceeded; for most of the time sound levels will be considerably lower.

Confirmation of the source sound level data used in the assessment is shown in Table 5 below.

| Description                               | Octave Band Frequency (Hz) – Leq (dB) |     |     |     |    |    |    |    | LAeq |
|---|---------------------------------------|-----|-----|-----|----|----|----|----|------|
|   | 63                                    | 125 | 250 | 500 | 1k | 2k | 4k | 8k |      |
| Rehearsal/Multiuse Rooms                  | 99                                    | 106 | 103 | 100 | 95 | 92 | 88 | 79 | 102  |
| 1 <sup>st</sup> Floor Teaching Classrooms | 95                                    | 94  | 96  | 86  | 81 | 80 | 80 | 76 | 91   |

Table 6: Anticipated source sound levels

### 5.2. Acoustic Assessment of Internal Operational Noise Transmission

Based on the anticipated source sound level and the measured level difference of the **existing building structure**, resultant sound levels inside the adjoining residential demises are shown below.

| <b>Rehearsal/Multiuse Rooms</b>   | <b>63</b> | <b>125</b> | <b>250</b> | <b>500</b> | <b>1k</b> | <b>2k</b> | <b>4k</b> | <b>8k</b> | <b>dBC</b> | <b>NR</b> | <b>Criteria Excess</b> |
|-----------------------------------|-----------|------------|------------|------------|-----------|-----------|-----------|-----------|------------|-----------|------------------------|
| 1 <sup>st</sup> Floor offices     | 61        | 67         | 58         | 48         | 45        | 38        | 31        | 15        | 68         | 52        | +27dB                  |
| 2 <sup>nd</sup> Floor residential | 60        | 69         | 52         | 40         | 28        | 19        | 11        | 4         | 69         | 54        | +21dB                  |

*Table 7: Calculated sound levels from the demise to adjoining residential premises – existing building structure*

| <b>Classrooms</b>                 | <b>63</b> | <b>125</b> | <b>250</b> | <b>500</b> | <b>1k</b> | <b>2k</b> | <b>4k</b> | <b>8k</b> | <b>dBC</b> | <b>NR</b> | <b>Criteria Excess</b> |
|-----------------------------------|-----------|------------|------------|------------|-----------|-----------|-----------|-----------|------------|-----------|------------------------|
| 2 <sup>nd</sup> Floor residential | 55        | 57         | 45         | 26         | 14        | 7         | 3         | 1         | 59         | 54        | +11dB                  |

*Table 8: Calculated sound levels from the demise to adjoining residential premises – existing building structure*

It is important to remember that the results in Table 6 & 7 are with the existing building structure and do not include any recommended mitigation. This confirms that mitigation treatments are required to the building structure to meet the requirements of the criteria as detailed within Section 2. Appropriate mitigation measures are detailed in the following section.

### 5.3. External Noise Egress

An assessment of noise emissions through the external façade has been carried out. The assessment considers the source sound levels shown in Section 5.1, along with the measured sound insulation performance of the existing façade shown in Section 4.1, together with the additional distance from the windows to the closest residential receptors.

Noise breakout through the façade of the proposed music school will result in a sound level of LAeq 40dB and LCEq 54dB at 1m from the nearest residential window. These levels do not exceed the external background sound levels of LA90 48dB/LC90 58dB shown in Table 4, therefore the criteria to outside residential receptors discussed in Section 2.1 will be met without any further mitigation measures.

These calculations are assuming the windows will be kept closed as the facility will have mechanical ventilation/air conditioning.

## 6. MITIGATION REQUIREMENTS

### 6.1. Acoustic Ceilings

It is understood that all of the rooms that contain any live music will be constructed as an independent 'room in a room' design. Neither the walls nor the ceilings of the rooms will be directly connected to the existing building structure. This type of design inherently provides a very high degree of sound insulation.

Appendix B of this document details the various wall and ceiling constructions which will be used for the different room types.

Acoustic doors should also be fitted to all of the rooms as per the details discussed in Appendix B.

### 6.2. 1<sup>st</sup> Floor Separating Wall

On the 1<sup>st</sup> floor there will be a separating wall between the music school demise and the adjacent office spaces. For this wall it is recommended that wall type T3 of Appendix B is used **in addition** to the independent room walls.

### 6.3. Calculated Resultant Sound Levels with Mitigation Scheme

The anticipated resultant sound levels inside the adjoining noise-sensitive receptors once the mitigation measures are implemented correctly, are shown below.

| Rehearsal/Multiuse Rooms          | 63 | 125 | 250 | 500 | 1k | 2k | 4k  | 8k  | dBC | NR | Criteria Excess |
|-----------------------------------|----|-----|-----|-----|----|----|-----|-----|-----|----|-----------------|
| 1 <sup>st</sup> Floor offices     | 47 | 38  | 11  | 9   | 13 | 12 | 10  | -6  | 43  | 19 | -6dB            |
| 2 <sup>nd</sup> Floor residential | 46 | 40  | 5   | 1   | -4 | -7 | -10 | -17 | 43  | 20 | -5dB            |

Table 9: Calculated sound levels from the demise to adjoining residential premises allowing for proposed mitigation

| Classrooms                        | 63 | 125 | 250 | 500 | 1k  | 2k  | 4k  | 8k  | dBC | NR | Criteria Excess |
|-----------------------------------|----|-----|-----|-----|-----|-----|-----|-----|-----|----|-----------------|
| 1 <sup>st</sup> Floor residential | 48 | 36  | 11  | -17 | -22 | -23 | -22 | -24 | 45  | 16 | -3dB            |

Table 10: Calculated sound levels from the demise to adjoining residential premises allowing for proposed mitigation

Table 9 & 10 above shows that the relevant criteria can be met with the above mitigation works implemented.

## 7. MECHANICAL PLANT

It is anticipated that the proposed music school will incorporate mechanical plant such as air conditioning condensers or ventilation fans.

It is understood the mechanical plant will be submitted as a separate planning application.

Plant details for the development are not yet known, however for the nearest noise-sensitive receptor, the plant shall be selected/located/mitigated to ensure the sound levels comply with the criteria set out in Section 2.2 and outlined in Table 10 below. This equates to a level at least 5dBA below the background sound level, when assessed in accordance with BS 4142:2014+A1:2019 and achieves a level of ‘normally acceptable’ as set out in Richmond’s SPD.

| Source Type      | Criteria (09:00 – 23:00) |
|------------------|--------------------------|
| Mechanical Plant | 43dBA                    |

Table 11: Design cumulative equipment sound levels at 1m outside noise-sensitive windows

## 8. CONCLUSION

A new music school facility is being developed at Richmond Brewery Stores, Petersham Road.

ACA Acoustics have carried out sound insulation tests on the separating floor between the proposed bar and adjoining residential and potential commercial premises. Based on anticipated source levels within the facility, resultant sound levels inside receptor demises will be within the limits stipulated by the local authority. This is subject to the mitigation works detailed in this report being implemented correctly.

External noise egress levels have also been assessed and also comply with the relevant requirements without any further mitigation measures.

Any new mechanical plant will be selected/mitigated to ensure that the noise levels produced at the nearest noise sensitive receptors also comply with the local authority requirements

## Appendix A

Sound Insulation Test Results



## Level Difference Measured in Accordance with ISO 140-4

### Field measurements of airborne sound insulation between rooms

**Project Name** School of Rock  
**Project Reference** 240901

**Client** Matias Puga  
**Test Date** 03/09/2024

#### 240901-AF01

#### Test on Floor between Ground and 1st Floor

**Description and identification of the building construction:**

**Source Room Volume (m<sup>3</sup>)** -  
**Receive Room Volume (m<sup>3</sup>)** -

--- Frequency range according to the  
 — Curve of reference values (ISO 717-1)

|       | <i>D</i> (one-third octave) dB |
|-------|--------------------------------|
| 50    | -                              |
| 63    | -                              |
| 80    | -                              |
| 100   | 33.0                           |
| 125   | 34.7                           |
| 160   | 40.7                           |
| 200   | 37.5                           |
| 250   | 39.2                           |
| 315   | 43.8                           |
| 400   | 47.1                           |
| 500   | 45.1                           |
| 630   | 44.2                           |
| 800   | 43.9                           |
| 1k    | 44.2                           |
| 1,25k | 46.4                           |
| 1,6k  | 46.7                           |
| 2k    | 49.8                           |
| 2,5k  | 49.7                           |
| 3,15k | 50.1                           |
| 4k    | -                              |
| 5k    | -                              |

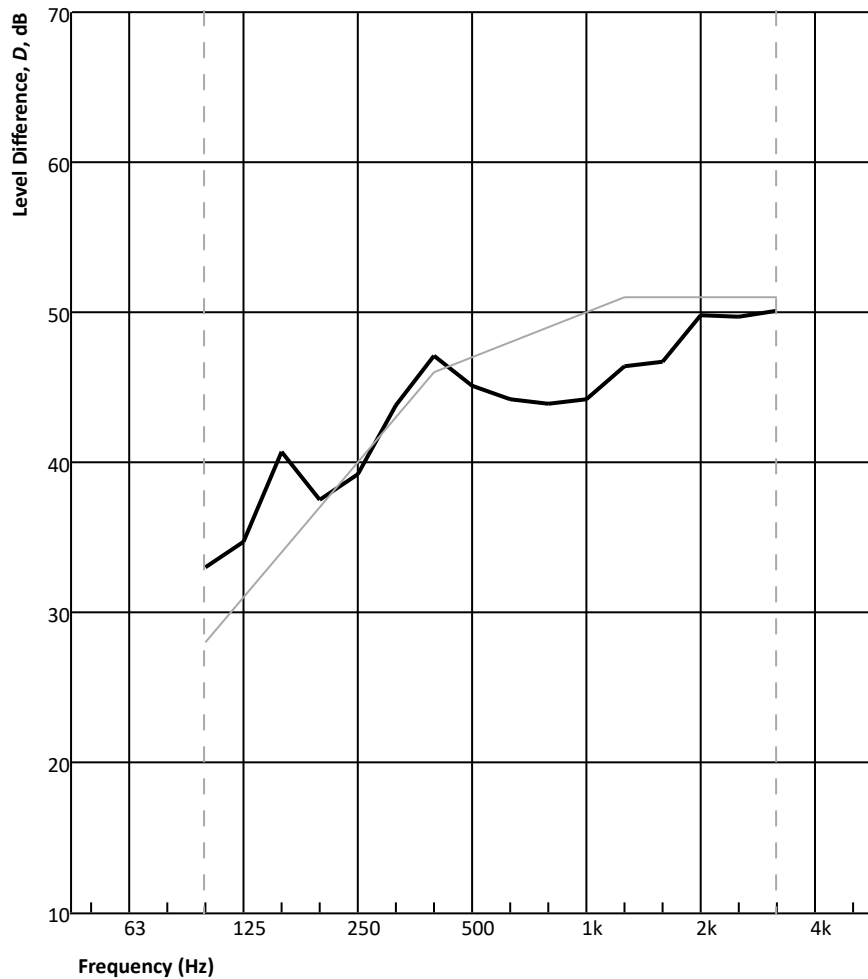

Rating according to ISO 717-1

**$D_w (C; C_{tr}) = 47 (-1; -3) \text{ dB};$**

$C_{50-3150} = -1 \text{ dB}; C_{50-5000} = 0 \text{ dB}; C_{100-5000} = 0 \text{ dB}$

Evaluation based on field measurement results obtained by an engineering method

$C_{tr, 50-3150} = -4 \text{ dB}; C_{tr, 50-5000} = -4 \text{ dB}; C_{tr, 100-5000} = -3 \text{ dB}$

**Date:** 05/09/2024

**Name of Test Institute:** ACA Acoustics

**Report Reference:** 240901 R1

**Signature:** SM

## Level Difference Measured in Accordance with ISO 140-4

### Field measurements of airborne sound insulation between rooms

**Project Name** School of Rock  
**Project Reference** 240901

**Client** Matias Puga  
**Test Date** 03/09/2024

**240901-AF02**

#### Test on Floor between Ground Office and 1st Office

**Description and identification of the building construction:**

**Source Room Volume (m<sup>3</sup>)** -  
**Receive Room Volume (m<sup>3</sup>)** -

--- Frequency range according to the  
 — Curve of reference values (ISO 717-1)

|       | <i>D</i> (one-third octave) dB |
|-------|--------------------------------|
| 50    | -                              |
| 63    | -                              |
| 80    | -                              |
| 100   | 42.7                           |
| 125   | 38.5                           |
| 160   | 45.7                           |
| 200   | 44.5                           |
| 250   | 51.0                           |
| 315   | ≥ 57.7                         |
| 400   | 61.1                           |
| 500   | 62.8                           |
| 630   | ≥ 64.7                         |
| 800   | ≥ 68.0                         |
| 1k    | ≥ 67.9                         |
| 1,25k | ≥ 69.5                         |
| 1,6k  | ≥ 69.8                         |
| 2k    | ≥ 73.7                         |
| 2,5k  | ≥ 75.9                         |
| 3,15k | ≥ 76.5                         |
| 4k    | -                              |
| 5k    | -                              |

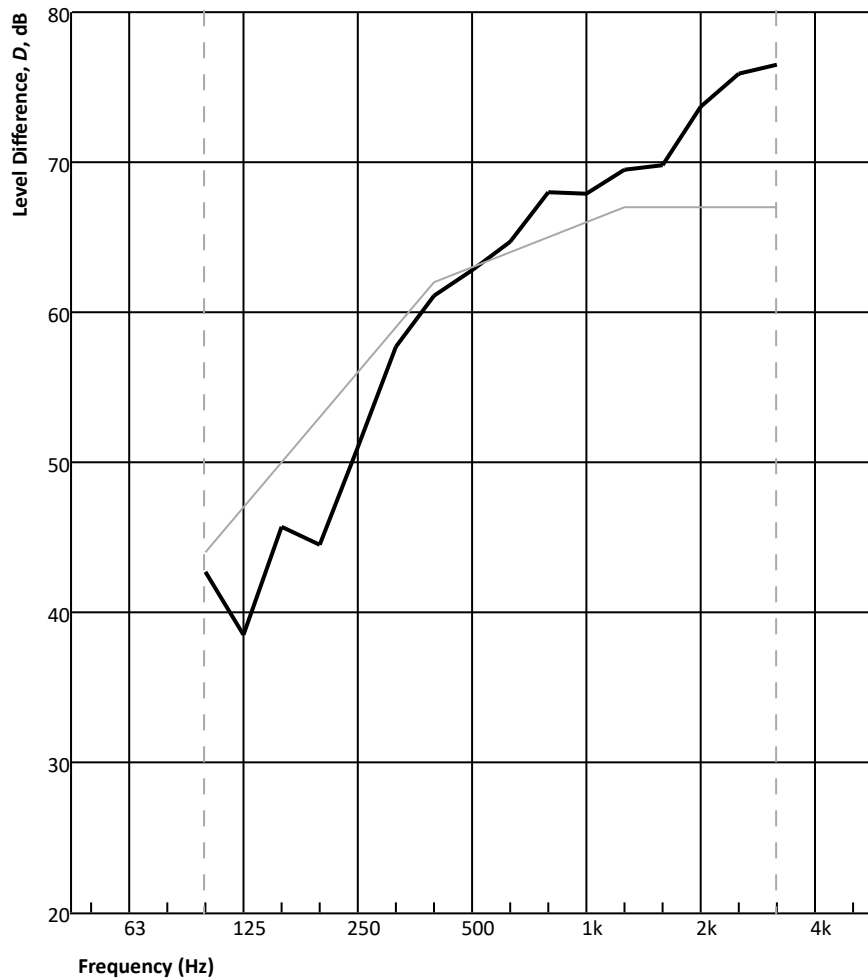

Rating according to ISO 717-1

**$D_w (C ; C_{tr}) = 63 (-3 ; -9) \text{ dB};$**

**$C_{50-3150} = -4 \text{ dB}; C_{50-5000} = -3 \text{ dB}; C_{100-5000} = -2 \text{ dB}$**

Evaluation based on field measurement results obtained by an engineering method

**$C_{tr,50-3150} = -11 \text{ dB}; C_{tr,50-5000} = -11 \text{ dB}; C_{tr,100-5000} = -9 \text{ dB}$**

**Date:** 05/09/2024

**Name of Test Institute:** ACA Acoustics

**Report Reference:** 240901 R1

**Signature:** SM

## Level Difference Measured in Accordance with ISO 140-4

### Field measurements of airborne sound insulation between rooms

**Project Name** School of Rock  
**Project Reference** 240901

**Client** Matias Puga  
**Test Date** 03/09/2024

**240901-AF03**

#### Test on Floor between 1st Floor and Resi Hallway

**Description and identification of the building construction:**

**Source Room Volume (m<sup>3</sup>)** -  
**Receive Room Volume (m<sup>3</sup>)** -

--- Frequency range according to the  
 — Curve of reference values (ISO 717-1)

|       | <i>D</i> (one-third octave) dB |
|-------|--------------------------------|
| 50    | -                              |
| 63    | -                              |
| 80    | -                              |
| 100   | 35.3                           |
| 125   | 37.2                           |
| 160   | 41.5                           |
| 200   | 48.5                           |
| 250   | 51.5                           |
| 315   | ≥ 57.2                         |
| 400   | 56.6                           |
| 500   | 65.6                           |
| 630   | ≥ 66.3                         |
| 800   | ≥ 67.7                         |
| 1k    | ≥ 66.1                         |
| 1,25k | ≥ 67.9                         |
| 1,6k  | ≥ 72.0                         |
| 2k    | ≥ 73.8                         |
| 2,5k  | ≥ 74.8                         |
| 3,15k | ≥ 76.6                         |
| 4k    | -                              |
| 5k    | -                              |

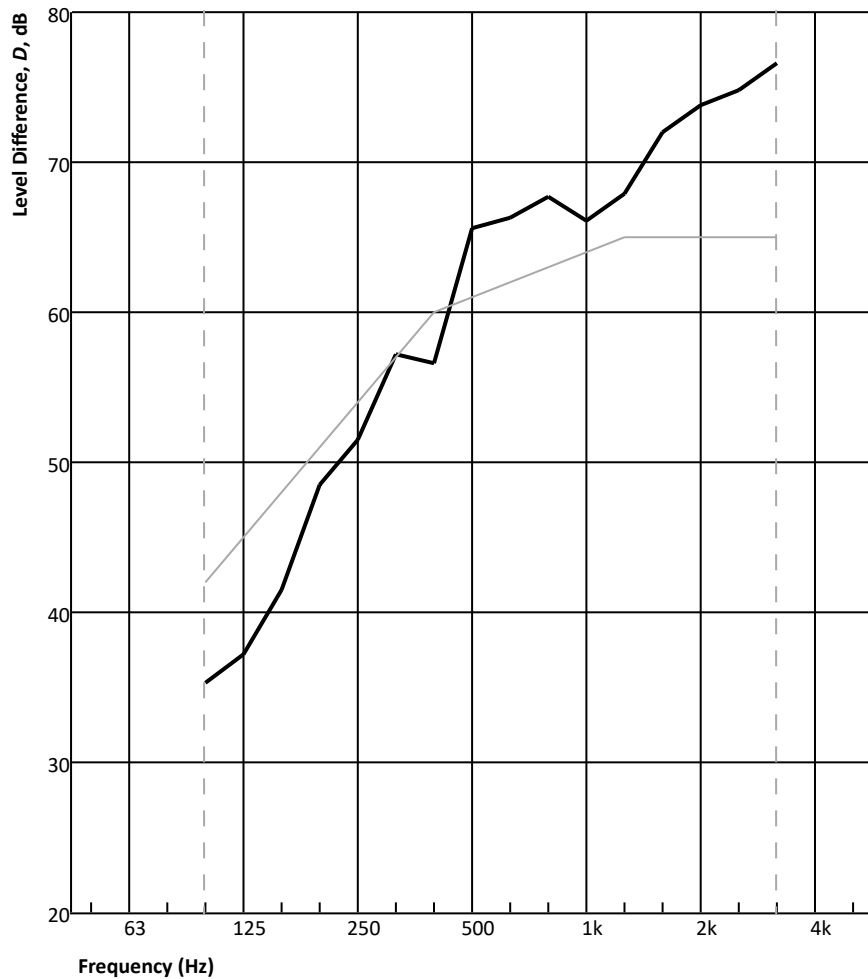

Rating according to ISO 717-1

**$D_w (C ; C_{tr}) = 61 (-3 ; -9) \text{ dB};$**

$C_{50-3150} = -3 \text{ dB}; C_{50-5000} = -2 \text{ dB}; C_{100-5000} = -2 \text{ dB}$

Evaluation based on field measurement results obtained by an engineering method

$C_{tr,50-3150} = -10 \text{ dB}; C_{tr,50-5000} = -10 \text{ dB}; C_{tr,100-5000} = -9 \text{ dB}$

**Date:** 05/09/2024

**Name of Test Institute:** ACA Acoustics

**Report Reference:** 240901 R1

**Signature:** SM

## Appendix B

Typical Partition Construction Details

## School of Rock Acoustic Insulation

The following acoustic solutions are being used by School of Rock in United States and Latin America to achieve a proper insulation and reduce noise impact. They provide a reduction of 50 Db - from 110 Db to 60- from interior of drum or rehearsal rooms to corridors and from then to outer space there another reduction of 20-30 Db. The reduction of noise is based in the principle of total insulation of each school room from inside. Walls and Ceilings are treated as insulated boxes, plus acoustics doors to ensure noise insulation.

### Walls

Depending on each type of room there are three types of wall acoustic solutions:

#### 1. Basic Wall Solution - T1

Used for office, storage room, bathrooms, teachers room.

This wall is constructed in 2 1/2" metal stud framing with with one layer of 5/8" drywall per each side plus fiberglass insulation

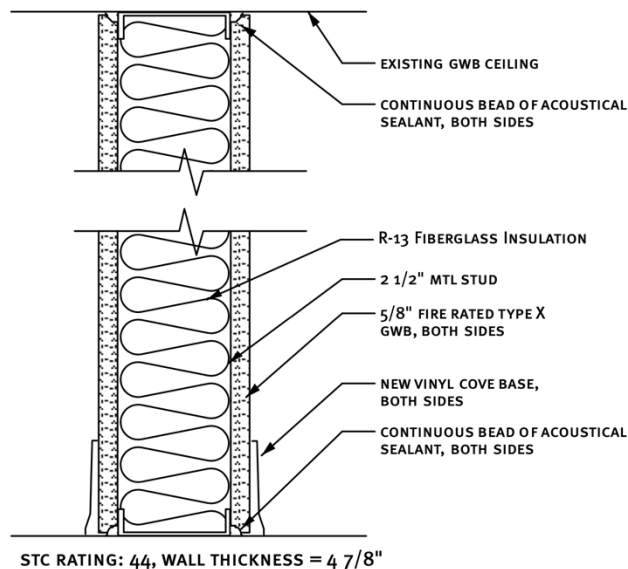

1. Figure. T1 Wall Type

## 2. Medium Acoustic Wall Solution – T2

Used for lesson room – guitar, bass, singing, piano or keyboard.

This wall is constructed in 3 5/8" metal stud framing with two layers of 5/8" drywall per each side plus a perimetral sealant. Drywall are stick and sealed with Green Glue.

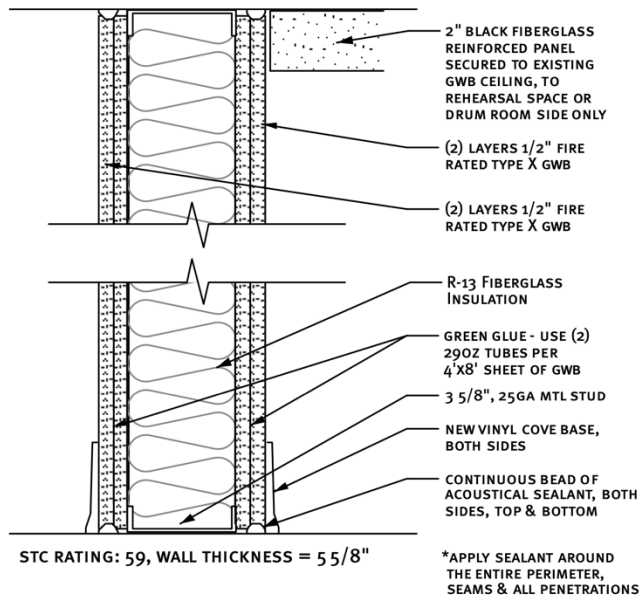

2. Figure. T2 Wall Type

### 3. High Acoustic Wall Solution – T3

Used for drum rooms and rehearsal rooms.

This wall is constructed with a metal framing of 3 5/8" metal stud, with two layers of 5/8" drywall per one side and three layers of 5/8" drywall for the other side plus a perimetral sealant. Drywalls are stick and sealed with Green Glue.

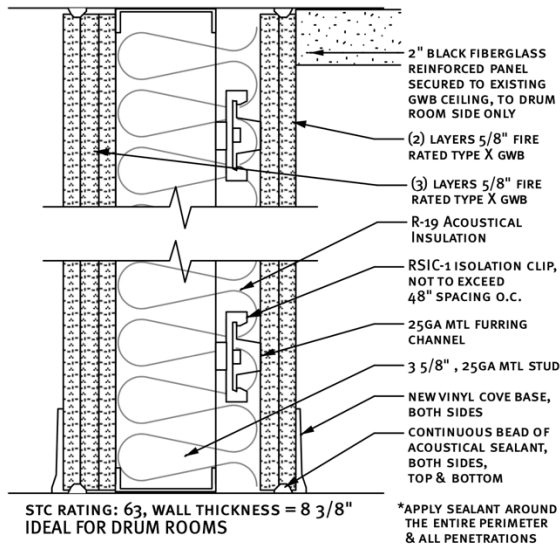

3. Figure. T3 Wall Type

## Ceiling

### 1. Medium Acoustic Ceiling Solution

Used for lesson room – guitar, bass, singing, piano or keyboard.

This is Ceil is constructed with steel frame “C” Stud 90x50x12.0 mm. plus two layers of 5/8” drywall bottom side and two layers of 5/8” drywall over the “C” Stud. Inside has 50 mm. of glass mineral wool. The drywall are stick and sealed with Green Glue.

4. Figure. Acoustic Ceiling Section Type proposed for Medium acoustic needs.

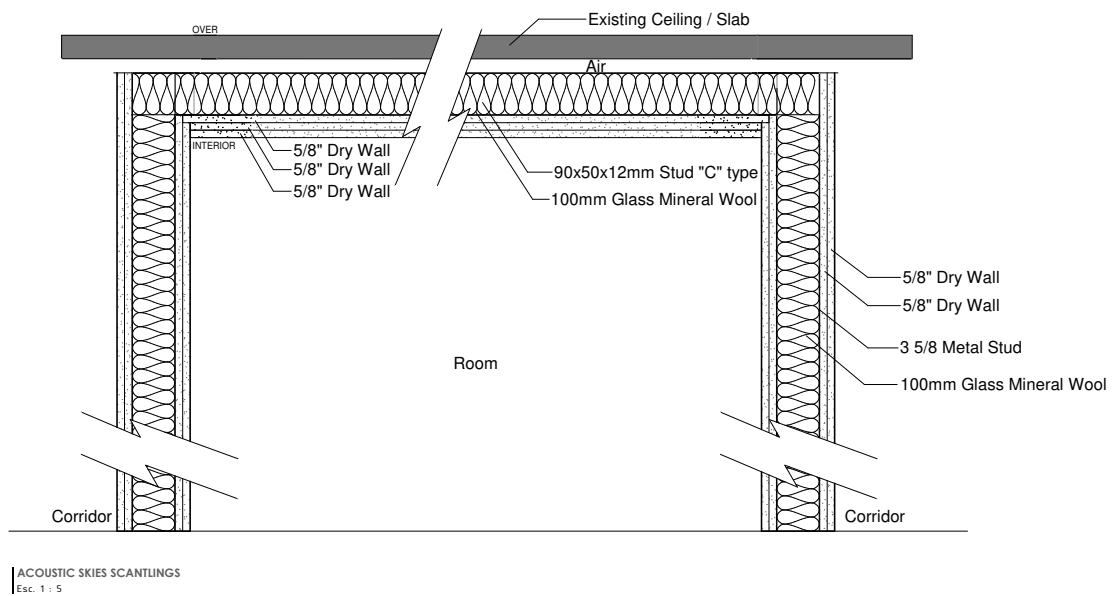



## 2. High Acoustic Ceiling Solution

Used for drum rooms and rehearsal rooms.

This is Ceil is constructed with “C” Stud 150x50x12.0 mm. plus two layers of 5/8” drywall bottom side and two layers of 5/8” drywall over the “C” Stud. Inside has 100 mm. of glass mineral wool. The drywall are sticked and sealed with Green Glue.

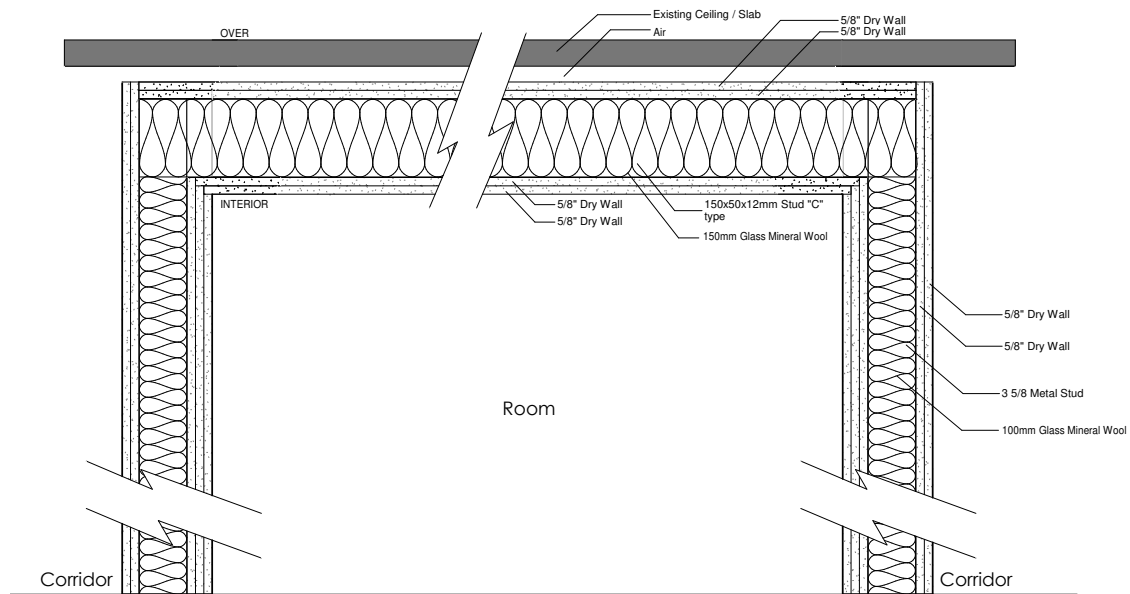

5. Figure. Acoustic Ceiling Section Type proposed for High acoustic needs.

## Doors

Doors are made with a solid interior. Double contact wooden frame and a tempered or double glassing glass – preferred – when using glass panel. An automatic door bottom is added in the inferior external side of the door to ensure acoustic sealing.

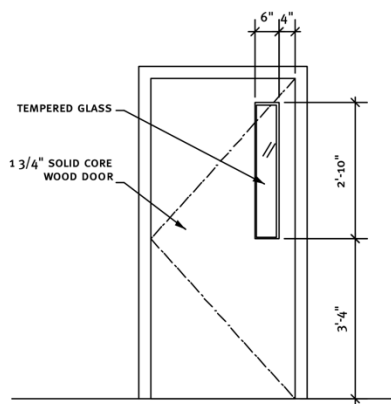

CD-2.1 : typical lesson room and rehearsal room door

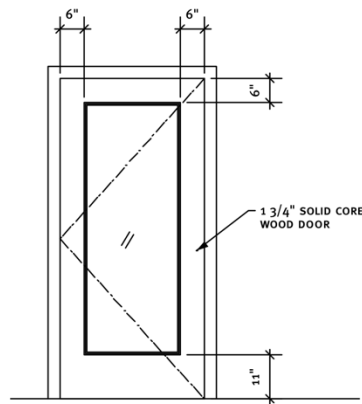

CD-2.2 : typical lounge, reception door

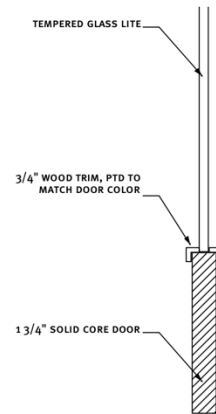

CD-2.3 : typical detail at lesson door lite

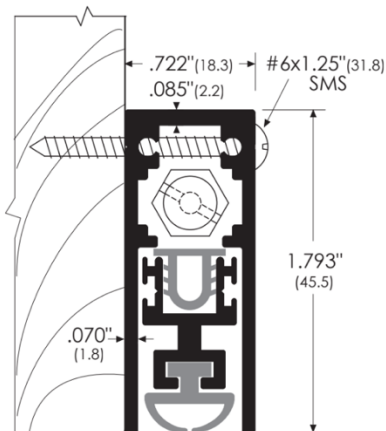

1. Figure. Acoustic Door Bottom. Model A351 Exterior.

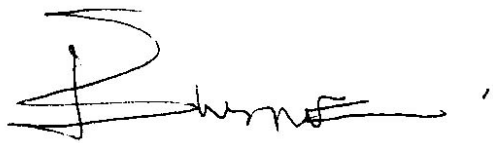
A handwritten signature in black ink, appearing to read 'Enrique González Barrenechea', with a stylized initial 'E' and a long horizontal stroke.

**Enrique González Barrenechea**  
Architect