



- Key**
- (A) Block A Refuse Store
  - (B) Block B Refuse Store
  - (E) Block E Refuse Store
  - (F1) Block F Core 1 Refuse Store
  - (F2) Block F Core 2 Refuse Store
  - (G) Block G Refuse Store
  - (2) House Types 2 & 2a Refuse Store
  - (3/8) House Types 3 & 8 Refuse Store
  - (4) House Type 4 Refuse Store
  - (6) House Type 6, 6a & 6b Refuse Storage (Garage)
  - (7) House Type 7 Refuse Storage (Garage)
  - Refuse Vehicle (Body) Tracking (See GTA Drawing 10198-1950-T1)
  - Refuse Vehicle (Wheels) Tracking (See GTA Drawing 10198-1950-T1)

**Notes**

The scheme has been designed in accordance with the London Borough of Richmond's Refuse and Recycling: Storage and Access requirements for New Developments (December 2022) document where practicable (see Technical Note).

For individual Refuse Store drawings refer to:

1597-P-002	Block A Refuse Store
1597-P-003	Block B (Commercial) Refuse Store
1597-P-004	Block E Refuse Store
1597-P-005	Block F Core 1 Refuse Store
1597-P-006	Block F Core 2 Refuse Store
1597-P-007	Block G Refuse Store
1597-P-008	House Types 2 & 2a Refuse Stores
1597-P-009	House Types 3 & 8 Refuse Stores
1597-P-010	House Type 4 Refuse Store
1597-P-011	House Types 6 & 7 Refuse Stores (Garages)

These detail the total number of bins required / provided for each Store.

Refuse vehicle tracking has been carried out by GTA Civils & Transport Consultants using the below Refuse truck in line with Council requirements. For further details refer to GTA drawing 10198-1950-T1.

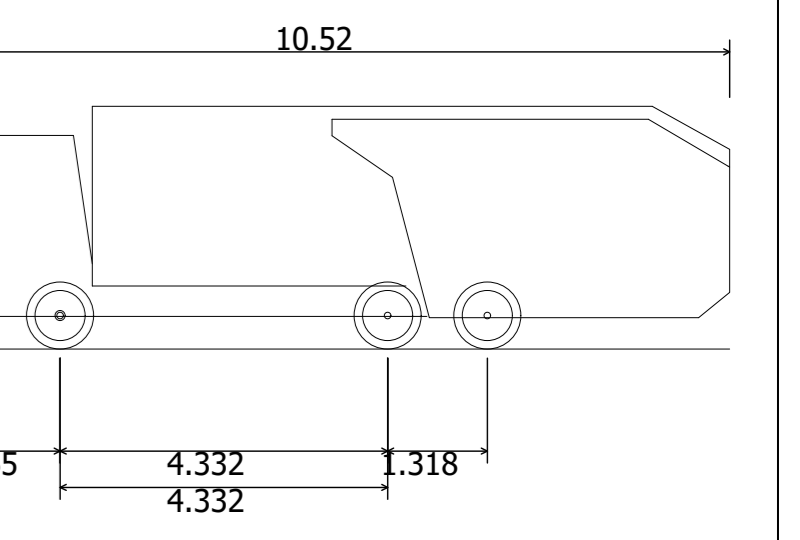

Overall Length 10.520m  
 Overall Width 2.530m  
 Track Width 2.530m  
 Kerb to Kerb Turning Radius 7.500m

This drawing has been produced pursuant to the submission in relation to the discharge Conditions U0178995 / U0178996 / U0178995 of Planning Consent 22/2556/FUL.

**Preliminary Issue**

**Stanford | Eatwell**  
 Architecture

01279 874613  
 www.stanfordeatwell.com  
 www.stanfordeatwell.co.uk

project: Gregg's Bakery Site, Twickenham  
 London Square

site: Proposed Refuse Store Locations

scale: 1:250 @ A0	date: LS
date: July 2024	dra: RH
fig no: 1597-P-001	rev: P2