

LOCATION PLAN - NOT TO SCALE

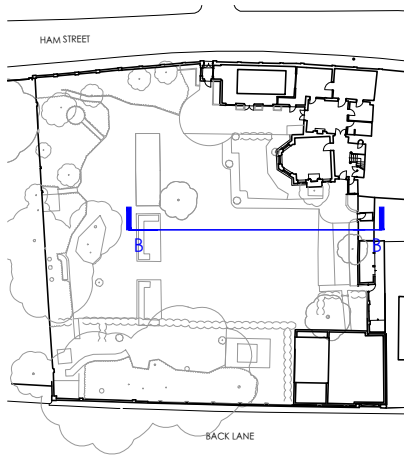

Existing Elevation
scale 1:100

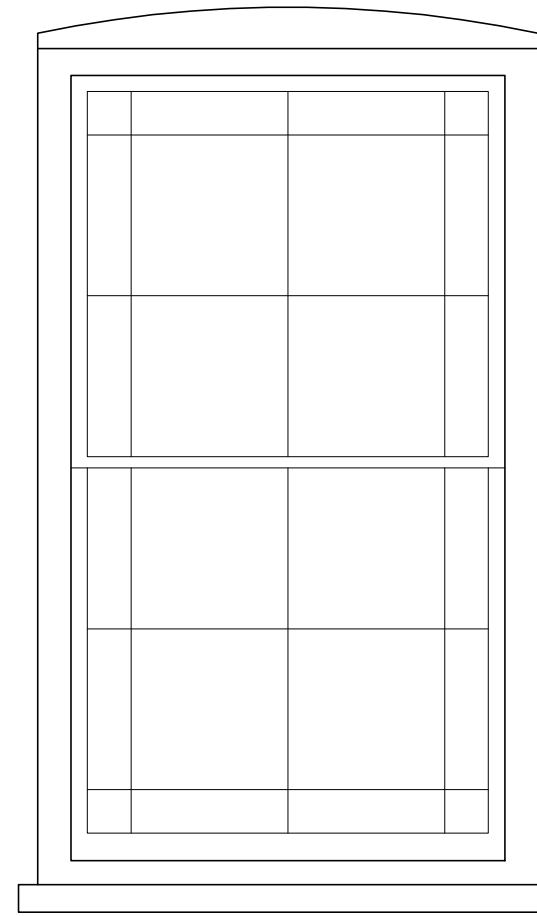

Existing Window Elevation
Timber Sash Window 12 over 12 cross bars (24 modules)
scale 1:20



Proposed Elevation
scale 1:100

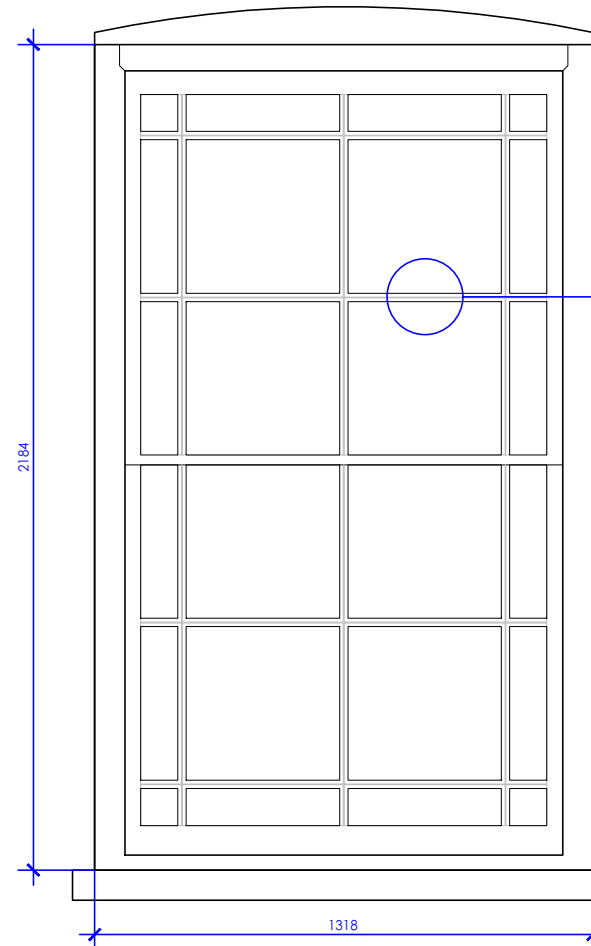

Proposed Window Elevation
Timber Sash Window 12 over 12 cross bars (24 modules)
scale 1:20

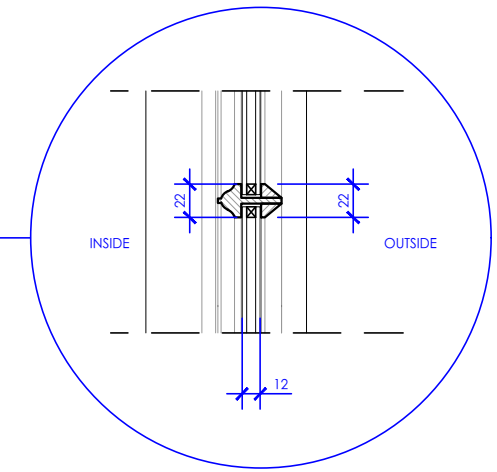

Proposed Sash Window Detail Section
scale 1:5

Glazing: Slim-line 12mm double glazed unit
Trickle vent: Concealed Trickle Vent
Frame colour: Inside & outside - RAL 9016 Traffic White
Glass spacer: Warm White
Silicone: White

