

Canopies are supplied without any roof coverings so that the client can choose their own finish.

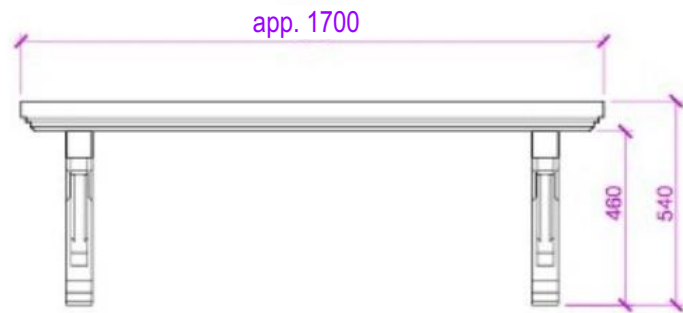

FRONT

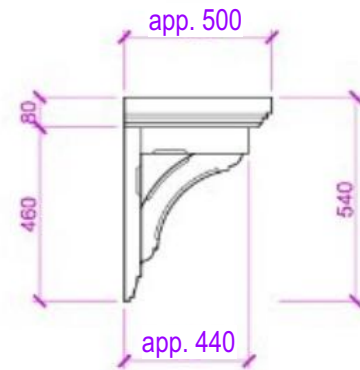

SIDE

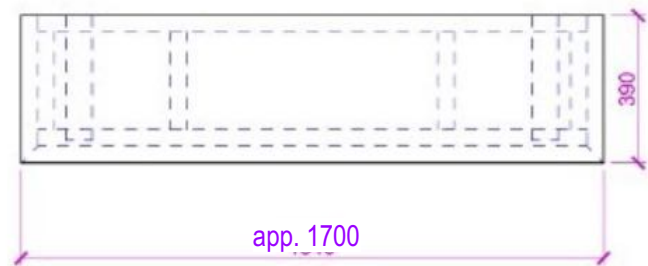

PLAN



ISOMETRIC

The standard Gittisham dimensions are: 1540mm wide x 540mm height x 390mm deep  
 The Gittisham design has a flat roof, this canopy can be used if your door has no space above for a pitched roof, this design can be modified both in depth and in width (up to 4.5 metres is possible).

Drawing Title	Drawing No.	<b>GW 07</b>
<b>GITTISHAM</b>	Scale	Date
	1:20 @ A4	Sept '11

**TIMBER DOOR CANOPIES**  
**BY**  
**GEORGE WOODS**  
 OR SIMILAR APPROVED  
 4D Yeo Vale Cross Industrial Estate, Lapford, Crediton, Devon EX17 6YQ  
 Tel: 01363 884218 Fax: 01363 884228 Mob: 07843 760054  
 www.timberdoorcanopies.co.uk  
 Email: georgewoods@tiscali.co.uk

- GENERAL NOTES**
- No dimensions to be scaled from this drawing, use figured dimensions only
  - This drawing is to be read in conjunction with all relevant consultants and/or specialist drawings/ documents and any discrepancies or variations are to be notified to the architect in writing before the affected works commence.
  - All dimensions and ex. structures to be verified by the contractor before work is commenced
  - (Architect) to be notified immediately if any discrepancies are found
  - All shop drawings to be approved by (client/ architect) before work commences.
  - All details, workmanship and materials of all trades and building operations shall comply with the relevant British Standards and EU norms and with the Approved Documents to Support Building Regulations and to manufacturer's recommendations and specifications.

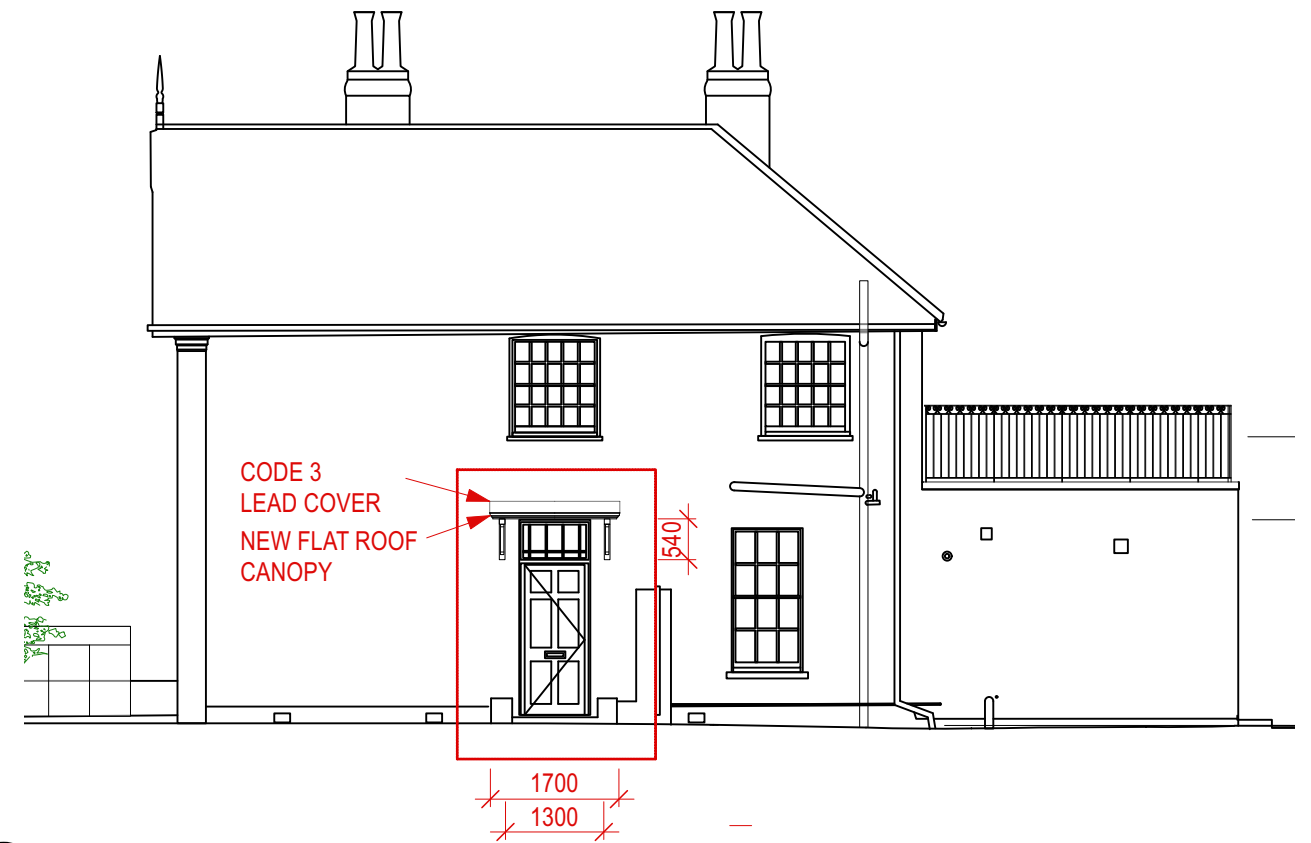

1 EAST ELEVATION AS PROPOSED  
 1:100

**PLANNING APPLICATION AND LBC - AS PROPOSED** 08.10.2024

 consulting . engineering . designing		PROJECT	PETITE KEW		REVISION			
		CLIENT	11 ST. JOHN'S GROVE RICHMOND, TW9 2SP		REV	DATE	DETAILS	BM
LONDON OFFICE	020 8940 7810	DRAWING	PORCH		DRAWING NUMBER		REVISION	
EXETER OFFICE	01392 363497	DATE	02.07.24		06659L	4-06		A
	info@structurehaus.com	SCALE	1: 50		Drawn by	BM	Checked by	DP
	www.structurehaus.com	06659L_TENDER.vwx			Date	02.07.24	Date	