

REAR

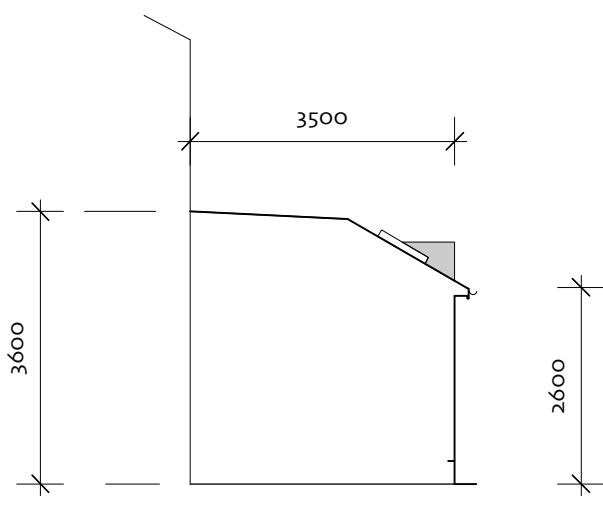

SIDE

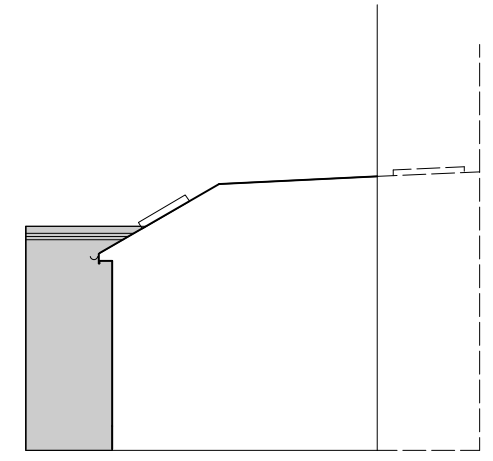

SIDE

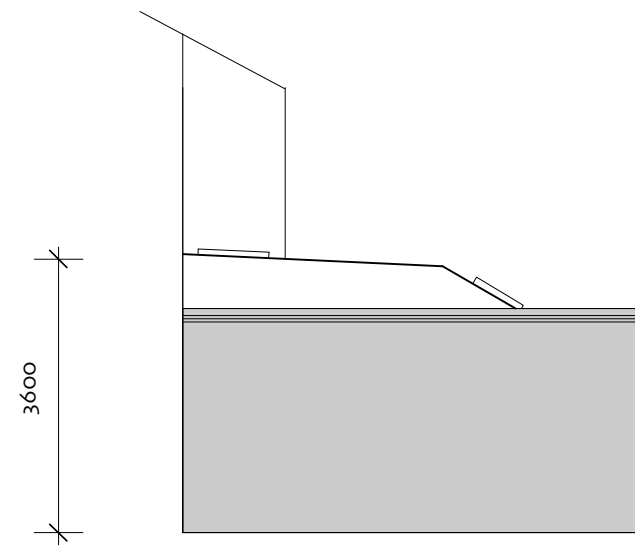

SIDE

Roof to be tiled to match existing
 Flat roof to be GRP
 Rear elevation
 outer skin to be rendered to match existing
 flank walls to have outer skin of brick
 Sliding doors to be anodised aluminium powder coated

no part of extension
 to encroach past
 boundary line

no 75

no 75

3500

3600

2600

3600