

03/1855/  
FU

Project No 02644	Drawing No L(0)16	Revision A
---------------------	----------------------	---------------

© ASH DESIGN CONSULTANTS LTD  
No part of this drawing may be reproduced without written consent. Do not scale from this drawing. All contractors must visit site and be responsible for taking and checking all dimensions relating to this work.

TRIDAL  
A member of Tribal Group plc

ISO 9001  
REGISTERED FIRM

Rev	Date	By	Amendment
A	12/06/03	Juan	North And South Block Footprint Updated Taking Into Account The Revised Floor Layout Plans. Foot Paths To The Eastern Side Of The Site Removed. Parking Bays To The Southern Car Park Rearranged To Accommodate Revised South Block Footprint. Cycle Parking Provided Throughout.

LONDON BOROUGH OF  
RICHMOND U.P.T. 11/05/07  
16 JUN 2007  
PLANNING

**LEGEND**

98 CYCLE PARKING SPACES PROVIDED  
41 CAR PARKING SPACES PROVIDED

Existing Buildings  
New Buildings  
Existing Tree Screen  
New Perimeter Reinforcement Planting For Existing Tree Screen

**ASH DESIGN**  
CHARTERED ARCHITECTS

RIVERSIDE OFFICES, BLOCK A, LITTLEBROOK BUSINESS PARK, DARTFORD, KENT DA1 8PZ  
Tel: 01322 627800 E-mail: ash@tribalps.co.uk  
Fax: 01322 290155 Website: www.tribalps.co.uk

SUITE 1, GRIMSTON GRANGE OFFICES, SHERBURN ROAD, TADCASTER, NORTH YORKSHIRE LS24 9BX  
Tel: 01937 833975 E-mail: ipan@tribalps.co.uk  
Fax: 01937 833512 Website: www.tribalps.co.uk

Client  
**St MARY'S COLLEGE TWICKENHAM**

Project  
**EXTENSIONS AND ALTERATIONS TO GWD ACCOMMODATION**

Drawing  
**SITE PLAN**

Date  
25/02/03

Scale  
1/300

Drawn by  
JB

Checked by  
Checked by

Project No 02644	Drawing No L(0)16	Revision A
---------------------	----------------------	---------------



CYCLE PARKING LAYOUT

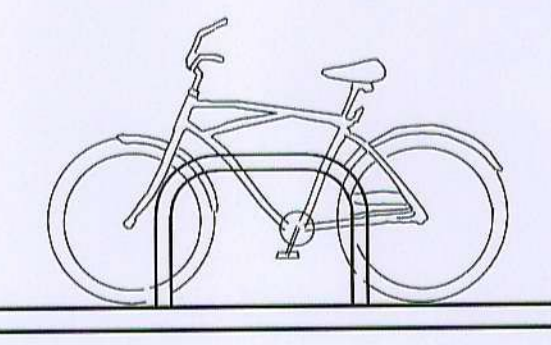
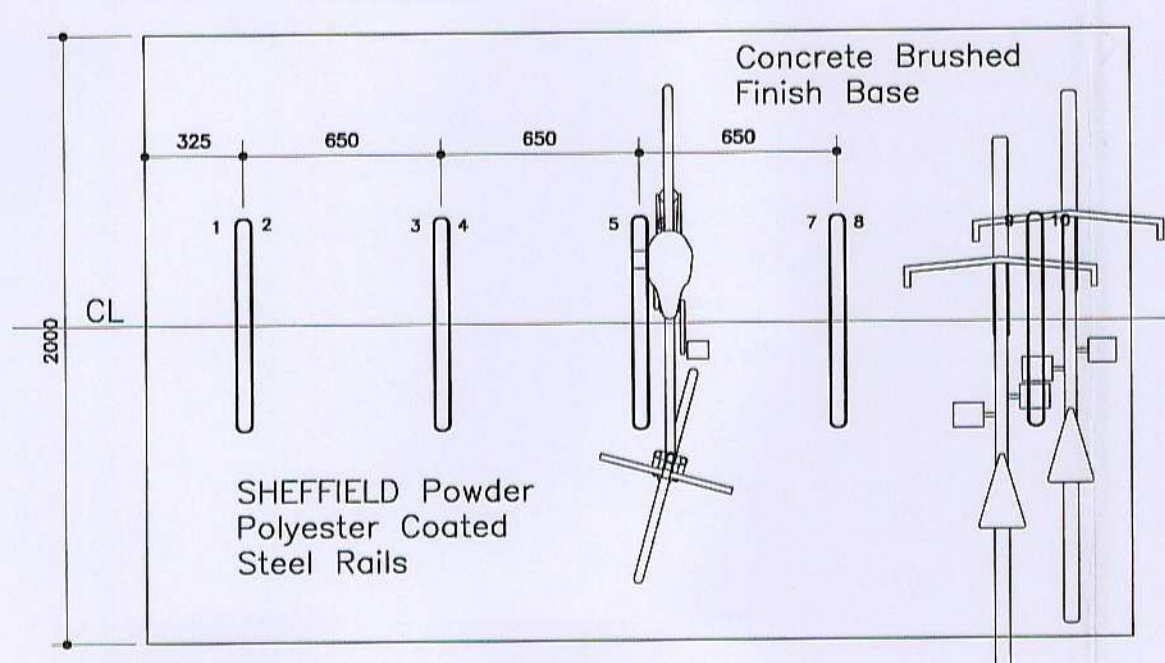

SHEFFIELD Powder Polyester Coated Steel Rails At 600 mm c/c

